

UNIT 2

BASIC TECHNICAL DRAWING EQUIPMENTS

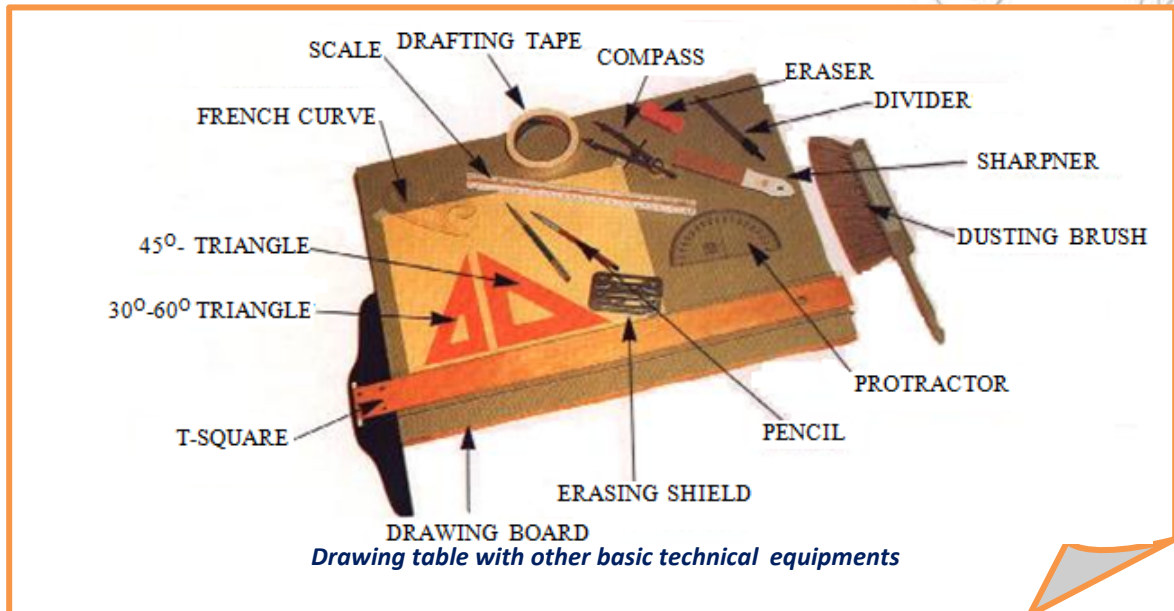

Learning competencies:

Up on completion of this unit you should be able to:

- ✓ Identify the difference between materials and instruments of drawing;
- ✓ List the different types of technical drawing materials and instruments ;
- ✓ Use drawing materials and instruments properly on making drawing of objects in activities;
- ✓ Prepare oneself for making technical drawing;
- ✓ Arrange appropriate working area before starting drawing;
- ✓ Prepare the title block on drawing paper.

2.1 Introduction

What are the type of drawing materials and instruments you already know before and try to list them?

For what purpose are you using them?

Technical drawings must be prepared in such a way that they are clear, concise, and accurate. In order to produce such drawings equipment (i.e. materials and instruments) are used. Because time is an important factor in any of work, a clear understanding of all drawing equipment and their uses is important to speed up the process of drawing preparation. In this chapter, the different types of drawing instruments and materials and their uses will be discussed.

2.2 Selection of Drawing Materials

The basic drawing materials which are necessary to prepare a technical drawing are:

- Drawing paper
- Drawing pencil
- Drafting or masking tape
- Eraser and erasing shield
- Rapidograph

2.2.1 Drawing Papers

Drawing papers are the materials on which the drawings are made. Depending on its application different types of drawing papers are available. These are: white plain paper,

profile paper, plan/profile paper, cross-section paper and tracing paper.

1. **White plain papers:** are general-purpose for office uses and drawings. They are manufactured according to ISO (International Organization for Standardization) standard paper sizes. Standard drawing sheet sizes are in three series, designated A_n , B_n , and C_n . Paper frames and drawing frames are standardized for each size of papers. Table 2.1 shows frames of the A-series and their particular application.
2. **Profile, Plane/ Profile and Cross-section papers:** are referred to as gridded papers. The first two are used for road design and the later one is used for drawing road cross sections, rough design, sketching, preparing schedules, plotting graphs, etc.
3. **Tracing paper:** is a high-grade white transparent paper, upon which copies or “tracings” are made for the purpose of reproducing by blueprinting or by other similar processes. Tracing may be made in ink, usually it takes ink well, and from which pencil lines can easily be erased. Reproductions (printing) can be made directly from pencil drawings on tracing paper (see Fig. 2.1); however, for better results in production, a pencil drawing on tracing paper is usually inked over. This paper must not be folded.



Fig. 2.1 Tracing paper

Drawing pencils with different grades of hardness are available. The grade of a pencil is designated by a number and a letter. The grades are 9B (very soft), 8B, 7B, 6B, 5B, 4B, 3B, 2B, B, HB, F, H, 2H, 3H, 4H, 5H, 6H, 7H, 8H, to 9H (very hard) see fig.2.3. Generally speaking, the soft (B) grades are used for freehand sketching and the hard (H) grades are used for instrumental drawings.

For mechanical pencils a wide variety of lead grades are available in different sizes, such as 0.3, 0.5, 0.7, and 0.9 diameters. Here, no sharpening of leads is necessary. The most common type of pencil is the wooden pencil shown in Fig.2.2 (a). To use this pencil, Fig.2.4 shows the acceptable sharpening of the wooden pencil.

Table 2.1 Paper and frame sizes for A-series

Designation	Paper frame size (mm)	Border width (mm)		Drawing frame size (mm)		Applications
		Left and right	Top and bottom	Width	Height	
A ₀	841 X 1189	28	20	1133	801	Technical drawings, posters
A ₁	594 X 841	20	14	801	566	
A ₂	420 X 594	14	10	566	400	Drawings, diagrams and large tables
A ₃	297 X 420	10	7	400	283	
A ₄	210 X 297	7	5	283	200	Letters, magazines, catalogs...
A ₅	148 X 210					Note pads

2.2.2 Drawing Pencils

One of the most important drawing materials is the drawing pencil. The two types of pencils used in drawing are mechanical and wooden pencils (see Fig.2.2).

Wood should be removed and the lead should be sharpened. To get good quality of line the pencil should be sharpened properly which means the lead should not be too sharp as it may pierce the paper and if it is

too dull the line will be thick and accuracy will go down.



a) **Wooden pencil**

b) **Mechanical pencil**

Fig.2.2 Drawing Pencils



Fig. 2.3 Pencil grades



Too sharp



Acceptable



Too dull

Fig.2.4 Sharpening of the wooden pencil

Activity 2.1

- Form a group up to five members and sharpen your pencils with different grade (like sharp, dull, average) and draw straight lines to observe the effect.

2.2.3 Drafting or Masking Tape

Before starting drawing, it is a common practice to attach the drawing paper to the drawing board in order to avoid unnecessary errors due to misalignment. Drafting tape is used for attaching the paper to the drawing board. Thumbtacks can also be used for fixing the paper to the drawing board. However, their use is not recommended because they have the tendency to affect the smoothness of the drawing board. Typical type of drafting tape is shown in Fig.2.5.



Fig.2.5 Drafting or masking tape

2.2.4 Eraser and Erasing Shield

In the process of making a drawing, corrections and changes may be required. To do so, erasers are used to clean unnecessary line works. An erasing shield restricts the erasing area so that the correctly drawn lines will not be disturbed during the erasing

procedure. It is made from a thin flat piece of metal with variously sized cutouts. The shield is used by placing it over the line to be erased and erasing through the cutout. Common types of eraser and erasing shield are shown in Fig.2.6 and Fig.2.7. respectively.



Fig.2.6 Eraser

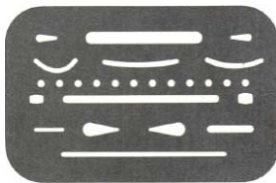

Fig.2.7 Erasing shield

2.2.5 Rapidograph

Rapidograph is a type of drawing pen by which lines are drawn on tracing papers. It produces light resistant, waterproof, precise and consistent ink lines for any application. Since most rapidograph pens require different pen sizes (line widths) for various projects, they are manufactured in different sizes.



Fig.2.8 Rapidograph

Activity 2.2

Practice line exercises by following the steps below.

1. On your paper, draw the borderline using your pencil by measuring 1 cm from the edge of the paper.
2. Draw four squares measuring 10 cm x 10 cm. Use your t-square and triangle.
3. Arrange the squares on the central part of the paper.
4. On the first square, draw vertical lines measuring 1 cm apart. Label it box A.
5. On the second square, draw horizontal lines measuring 1 cm apart. Label it box B.
6. On the third square, draw inclined lines at 30° at a distance of 1 cm apart from each other. Label the third square box C.
7. In the fourth square, draw inclined lines at 45° at a distance of 1 cm apart from one another. Label the last square box D.

Evaluate your work using the criteria below.

Criteria	5-Excellent	4-very Good	3-Good	1-Poor
1. The lines in Box A and B are spaced at 1 cm equally from each other.				
2. The lines in Box C are angled at 30°				
3. The lines in Box C are angled at 45°				
4. The border line is drawn in straight heavy lines and corners are angled at 90°				
5. The borderline is 1cm away from the edge of the paper.				

2.3 Selection of Drawing Instruments

The list of main drawing instruments is shown below:

- | | |
|---------------------|-----------------|
| 1. Drawing board | 7. Protractor |
| 2. Dusting brush | 8. French curve |
| 3. Templates | 9. French curve |
| 4. Pencil sharpener | 10. T-Square |
| 5. Scale | 11. Divider |
| 6. Set square | 12. Compass |

2.3.1 Drawing Board

Drawing boards are usually made of white pine, but are sometimes made of other soft woods. The drawing surface may be the table top itself or a separate board. In both cases, the working surface (the drawing surface) should be flat, smooth and firm. For this reason, the working surfaces of drawing boards or table tops are made of soft white pine or basswood. The working edge of a drawing board must be straight and should be tested with a steel straight edge. To prevent wear of the working edge some boards and table tops are furnished with a hardwood edge or steel insert on the working edge.

Drawing boards are made in various sizes. Those usually used in school measure 23×30 cm, 40×53 cm or 46×60 cm. The smallest size is mostly used for field work or sketching. The type shown in Fig.2.9 (a) is the most common type of drawing board. Depending on their design, drawing tables may be fixed in height or can be adjusted to any desired working height. Most industrial drawing drafting is done on tables similar to that shown in Fig. 2.9(b). Portable drawing boards are very handy for professionals as well as students. You can use these small drawing boards as tabletop drawing boards, handy reference boards, and drawing holders.

The tracing table shown in Fig. 2.9 (d), is another accessory that facilitates the draftsman work. A tracing table allows us to trace another work too blurred or dirty on a new paper. It provides the advantage of rectifying errors, such as stains or mistaken lines of ink, or other mistakes non correctable in some other surfaces. Sometimes it simply helps us to improve the presentation of the drawings.



a) Drawing tables



b) Drafting machine



c) Portable drawing board



d) Tracing table

Fig. 2.9 Drawing board

2.3.2 Dusting Brush

During erasing, particles coming from the eraser will remain on the drawing paper. These particles are removed or cleaned using a dusting brush such as shown in Fig.2.10. It is poor practice to use fingers or palm of the hand for cleaning the drawing paper.



Fig. 2.10 Dusting brush

2.3.3 Drawing Templates

A template is a thin and flat piece of plastic containing various cutout shapes. It is designed to increase the speed and accuracy of the drafter. Templates are available for drawing geometric shapes (Fig.2.11a), plumbing fixtures, bolts, nuts, screw threads, electronic symbols (Fig.2.11c), springs, gears and much more. A template should be used whenever possible to increase the accuracy and the speed. The most commonly used type of drawing templates are shown in Fig. 2.11.

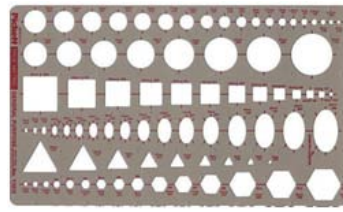

a) Geometric shapes drafting template

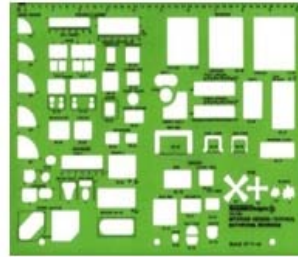

b) Architectural drafting template

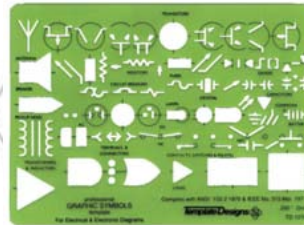

c) Electrical drafting template

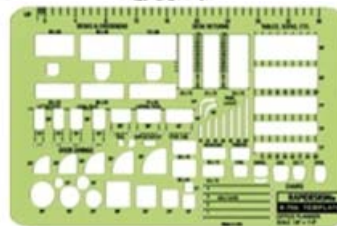

d) Office design drafting template

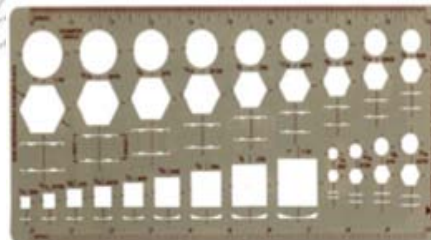

e) Screw head template

Fig.2.11 Different types of drawing templates

2.3.4 Pencil Sharpeners

Pencil sharpeners are drawing instruments used for sharpening pencils and they may be operated manually or by an electric motor and therefore a mechanical pencil sharpener is hand-powered. A common, portable variety is usually small and in the shape of a rectangular prism, with a conical hole on the small end. A sharp blade is mounted in a recess on the largest side such that its sharp edge just enters the cone. The body of the sharpener is often contoured, ridged or grooved to make it easier to grip firmly. It has no moving parts - the tip of the pencil is inserted into the hole of the sharpener and twisted, while the sharpener is held motionless. The blade inside the sharpener shaves the wood of the pencil, thus sharpening the tip, while the shavings emerge through a slot along the blade edge. An important feature is a larger clearance hole at the end of the cone allowing sections of the pencil lead which break away to be removed with only minor inconvenience. There are different types of pencil sharpeners out of which the two most commonly used are shown in Fig.2.12.

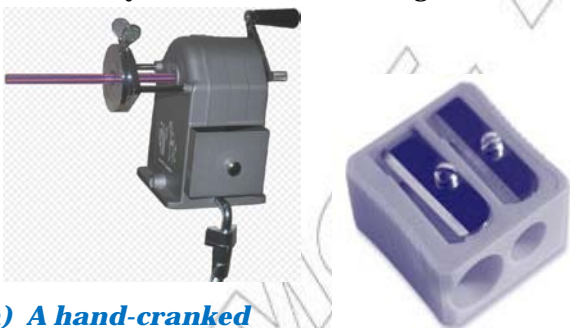

a) A hand-cranked Planetary sharpener b) A manual prism sharpener

Fig.2.12 Sharpeners

2.3.5 Scales

1. What is scale?
2. What example can you give on scaling?

A scale is an item of drawing instrument that has been carefully graduated (marked) and calibrated (labeled) in convenient increments for the user. Scales enable a user to make size reductions or enlargements rapidly and accurately. Scales are graduated in such a way that they can be used to draw objects to scale by direct measurement without any calculation. Depending on its size, the drawing of an object may be the same size as the object, larger or smaller than the object. When one unit on the object equals one unit on the drawing, we say the object is drawn to full size scale; written as 1:1. When one unit on the object is equal to two units on the drawing, we say the object is drawn to a magnification scale of 2:1. Where as when two units on the object is equal to one unit on the drawing, we say the object is drawn to a reduction scale of 1:2. Similarly, a scale of 1:10 means one unit on the drawing is equivalent to ten units on the object and so on.

Designation of a scale consists of the word “scale” followed by the indication of its ratio, as shown in the Table 2.2:

Table 2.2 Designation of Scale

Designation	Description
SCALE 1:1	Full scales
SCALE X:1	Enlargement scales
SCALE 1:X	Reduction scales

$$\text{Scale} = \frac{\text{Measurement on drawing}}{\text{Measurement on the actual object}}$$

Note: X is greater than 1 in both cases

Scales are available in either flat or triangular shapes as shown in Fig.2.13 (a) and (b). The advantage of a triangular scale is that more number of measuring faces are found in one stick.

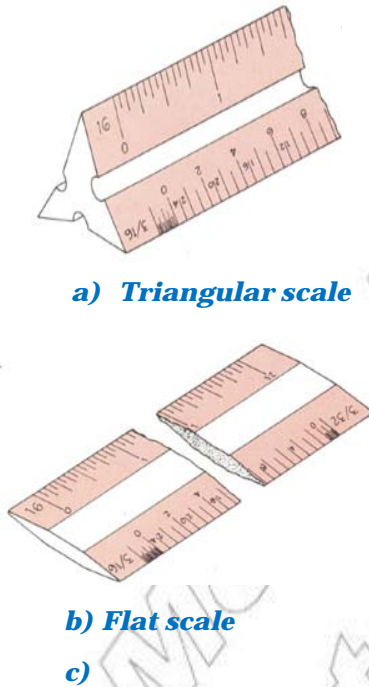

Fig.2.13 Triangular and flat type scales

2.3.6 Triangles (Set-squares)

Triangles are sometimes called setsquares. The capability of rapidly producing straight lines on instrument drawings is provided by the 30-60° and 45° triangles (Fig.2.14). Whereas adjustable triangles have a movable leg that is held in place with a thumbscrew and a scale for measuring angles. These instruments are useful for drawing such inclined lines as the slope of a stair or the pitch of a roof.

Using the triangles as a pair, you can generate parallel and perpendicular lines and produce angles of a multiple of 15°. Parallel lines are produced by establishing one side of a triangle along the given line or line direction. The supporting triangle is then fixed against one of the other sides of the first triangle.

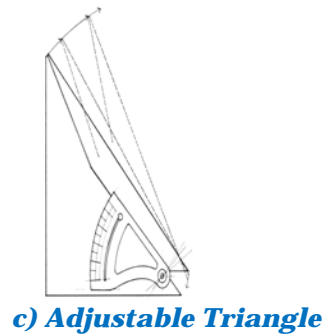
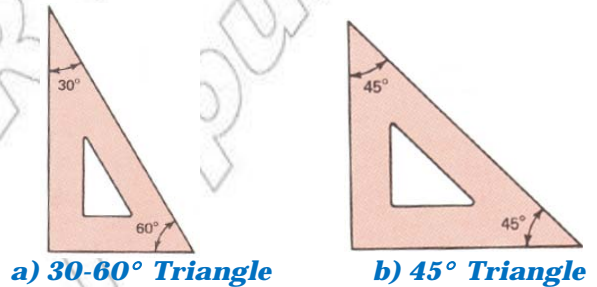

Fig. 2.14 Triangles

The first triangle is slipped along the supporting triangle to any desired position, and the parallel line is drawn (Fig. 2.15). Perpendicular lines may be produced by either the sliding triangle method or the revolved triangle method. The sliding triangle method is shown in Fig. 2.16. One leg of a triangle is placed along the given line. The supporting triangle is then fixed against the hypotenuse of the first triangle then the opposite leg of the first triangle is positioned by sliding, and the desired perpendicular line is drawn. The revolved triangle method which is illustrated in Fig.2.17 requires fixing the two triangles together so that the given line is along the hypotenuse of the first triangle and the supporting triangle is fixed against one leg of the first triangle. Simply revolve the first triangle until the opposite leg rests against the supporting triangle, and the perpendicular line can be drawn.

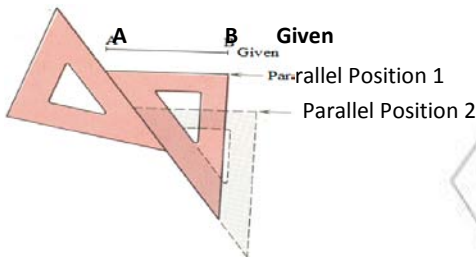

Fig.2.15 Parallel line construction

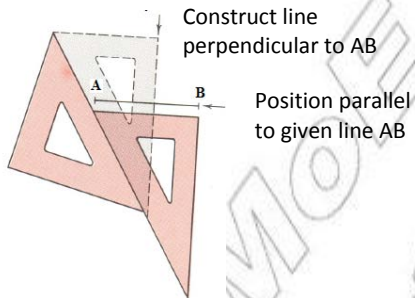

Fig.2.16 Construction of perpendicular line by sliding line method

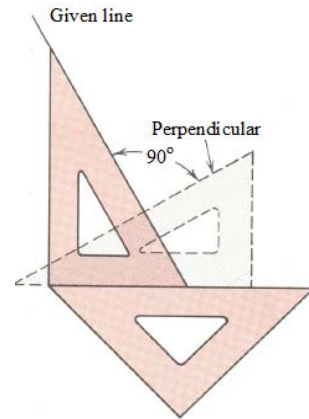

Fig. 2.17 Construction of perpendicular line by rotating triangle method

2.3.7 Protractor

For measuring or setting off angles other than those obtainable with the triangles, the protractor is used. A typical protractor used for measuring angles is shown in Fig.2.18. You have most likely used this instrument in a geometry or trigonometry course.

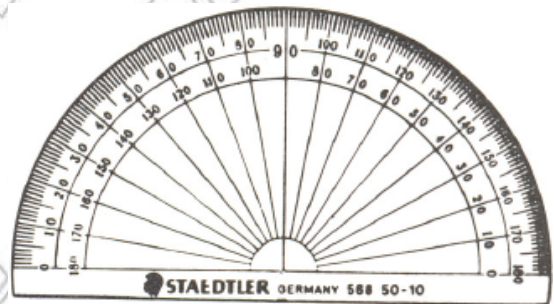

Fig.2.18 Protractor

2.3.8 French Curve

When it is required to draw mechanical curves other than circles or circular arcs, a French curve is generally employed. Many different forms and sizes of French curves are manufactured, as suggested by the more common forms illustrated in Fig.2.19. The

curves are composed largely of successive segments of the geometric curves, as the ellipse, parabola, hyperbola, involutes, etc. The best curves are made of highly transparent celluloid.

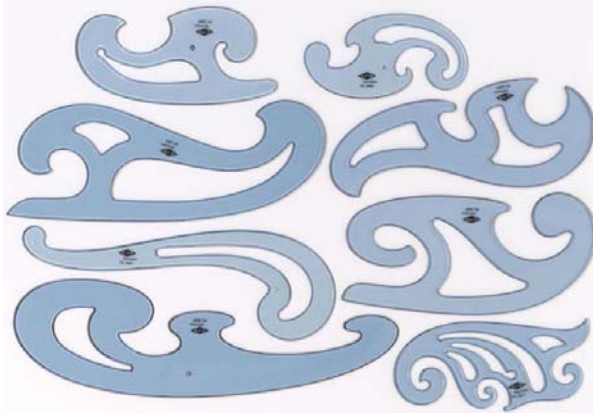

Fig.2.19 .French curves

2.3.9 T-Square

Another important drawing instrument is the T-square. There are different types of T-squares as shown in Fig.2.20. The upper edge of a T- square and the inner edge of its head are called the working edges of the T-square. The working edges of a good T-square should be straight and right angle with each other. The common type of T-square is that shown in Fig. 2.20(a). Basically, the T-square is used to draw horizontal lines and to support or guide the set squares. However, T-squares such as shown in Fig.2.20 (b) and (d) can also be used to draw inclined lines because their heads are adjustable. The type shown in Fig.2.20(c) is seldom used, perhaps because of the unusual design of the blade, but it has an advantage of rigidity.

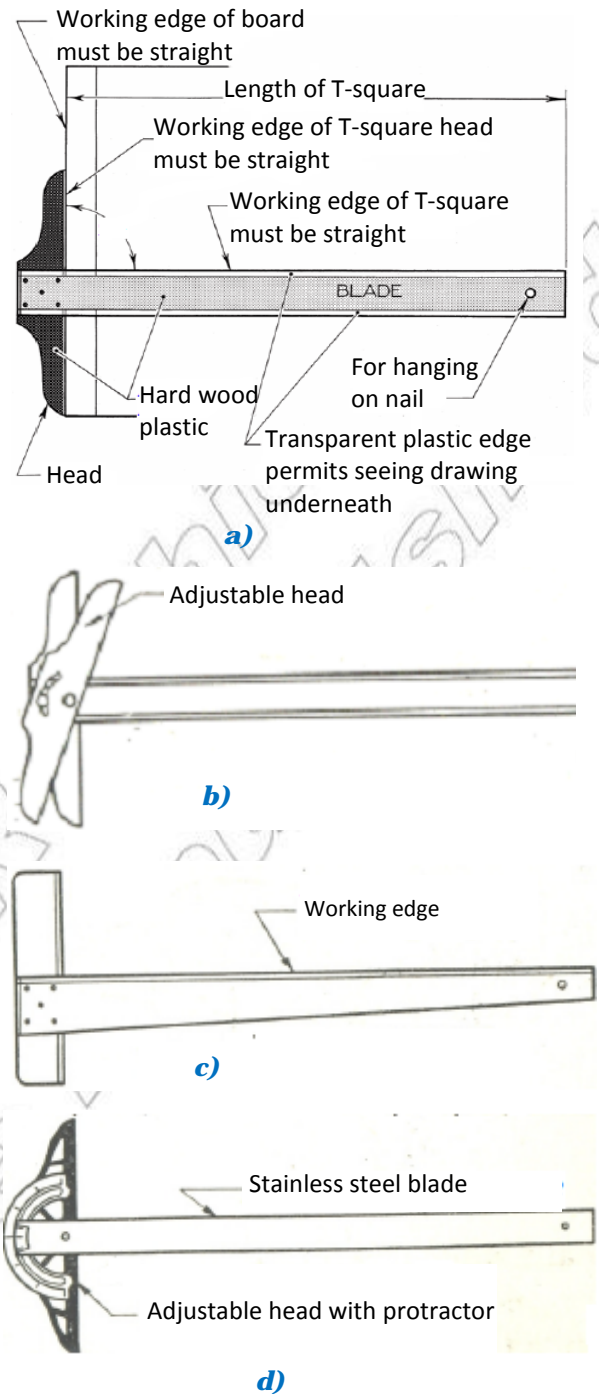

Fig.2.20 T-Squares

2.3.10 Divider

A divider is a drawing instrument used for dividing distances into equal parts or for laying off a series of equal spaces. Dividers like shown in Fig.2.21 are designed to be operated with one hand and are used for making distances or transferring measurements. Specified measurements can be obtained from scales or another drawing and transferred to the drawing being prepared. Figure 2.21 illustrates how the dividers may be used to create a double sized drawing simply by transferring measurements, thus avoiding the necessity of measuring each length and doubling the measurement.

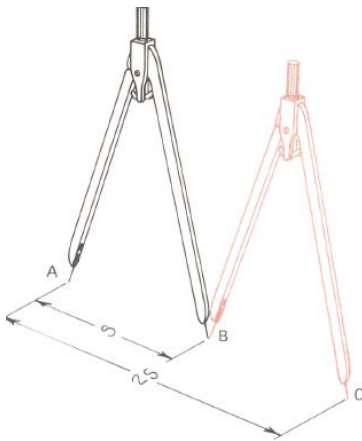

Fig. 2.21 Divider

2.3.11 Compass

Compasses are used to draw circles and arcs. Depending on their application we can divide them into two, bow compass and beam compass as shown in Fig.2.22 (a) and (b) respectively. The beam compass type is used for drawing circles and circular arcs larger than those made by the bow compass and for transferring diameters those are too great for the regular dividers.



a) Bow compass



b) Beam compass

Fig.2.22 Types of compasses

Project work

Go to the nearest art or engineering supply store. Ask the saleslady to help you identify the different tools, instruments and equipment used in drafting or drawing. List the current price of each instrument and equipment.

2.4 Application of Basic Technical Drawing Equipments

Until now we were discussing about the materials and instruments used in technical drawing, now we will see the proper use of this equipments.

Activity 2.3

- Visit an architectural or engineering student in your neighborhood. Interview him/her about the different tools, instruments and equipment he uses. Ask him/her to show you how each tool is used.

2.4.1 Preparation for Drawing

Before starting the drawing you have to fulfill the following points:

- Make sure that all the necessary drawing instruments are ready and clean.
- Position your drawing board to minimize effects of shadows.
- Clean your drawing board.

2.4.2 Fixing Drawing Paper to the Board

When attaching the drawing paper to the board follow the steps below:



- a) Place a paper close to the left edge of a table



- b) Place a T-square and move the paper until its lower edge lies close to the top edge of a T-square



- c) Align the top edge of the paper with T-square blade.

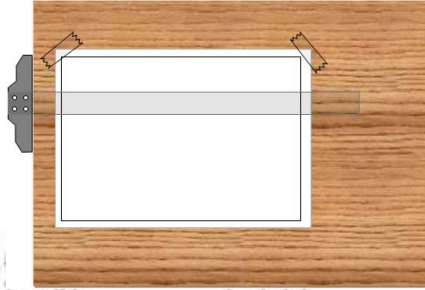

- d) Attach the paper's corners with tape.

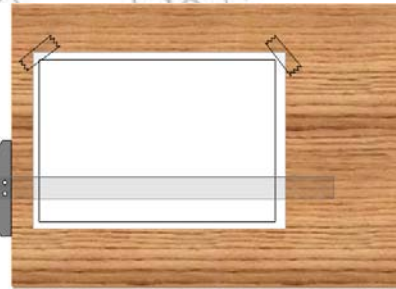

- e) Move T-square down to smooth the paper

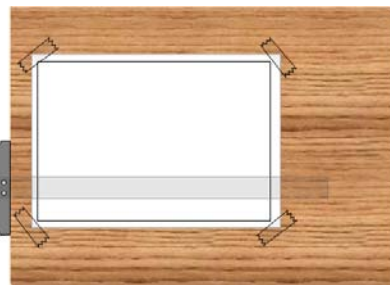

- f) Attach the remaining paper's corners with tape.

Fig.2.23 Fixing paper to the board

2.4.3 Selecting Pencils

Once the drawing paper is properly fixed, the next step is to start drawing. Pencil drawings are made using pencils. As discussed earlier, there are different types of pencils. Therefore, pencils should be selected based on the type of drawing. (See Section 2.2.2)

Depending on their hardness, pencils are generally classified into three groups; HARD, MEDIUM, and SOFT. The hard groups are generally used for light construction lines, the 4H, 5H, and 6H being common in technical drawings. In the medium group, the softer grades (F, HB, and B) are used for technical sketching and the harder grades (H, 2H, and 3H) are used for finished line work on technical drawings. The pencils in the soft groups are used for art work of various kinds but are too soft to be used in preparation of technical drawings.

2.4.4 Sharpening Leads of Pencils and Compass

To sharpen leads of pencils and compass follow the following steps:

- Remove the wood with penknife while exposing a lead about 8-10 mm. (See Fig.2.24 (a))

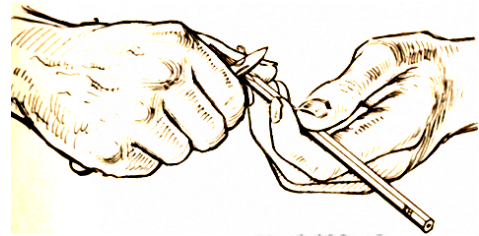

a)

- Polish the lead into a conical shape with sandpaper. (See Fig.2.24 (b))

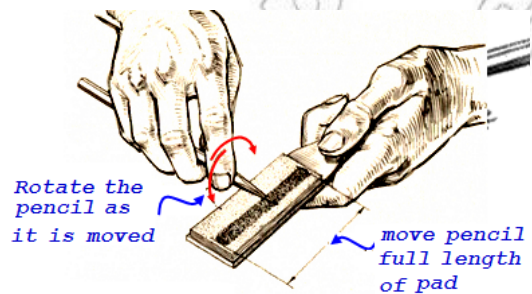

b)

- Clean the lead with tissue paper. (See Fig.2.24 (c))

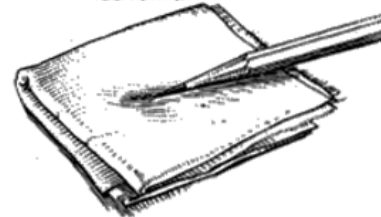

c)

Fig. 2.24 Pointing the lead

2.4.5 Drawing Horizontal Lines

Horizontal lines are always drawn from left to right using the T-square as shown in Fig.2.26. Note that T-square head should be held firmly against the board in order to produce accurate lines. When drawing straight lines, the pencil should lean in the direction in which the line is being drawn, at an angle of about 60° with the paper.

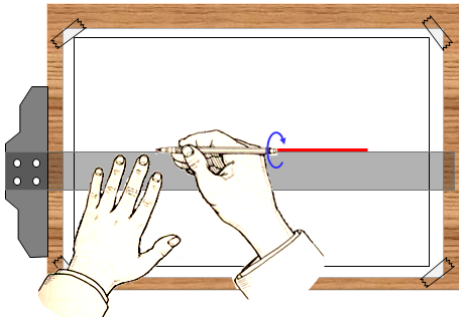

Fig. 2.25. Drawing horizontal line using T-square

2.4.6 Drawing Vertical Lines

The T-Square is used to guide or support the set-squares when drawing vertical lines as shown in Fig.2.26. Here also, the head of the T-square should be held firmly against the board to ensure the verticality of the lines to be drawn. Note that vertical lines drawn in the upward direction along the vertical legs of the triangles.

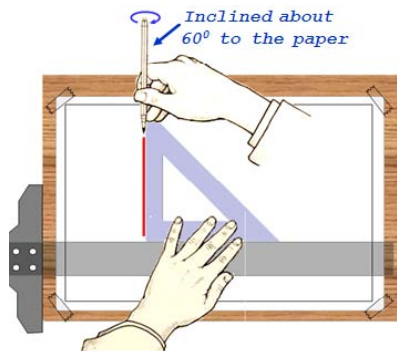

Fig. 2.26. Drawing vertical line using T-square

2.4.7 Drawing Inclined Lines

Lines inclined at any angle can be drawn using a straight edge ruler after locating any two points on the line using protractor.

However, lines inclined at an angle equal to (15° , 30° , 45° , 60° , etc) can be drawn using the T-square and set-squares as illustrated in Fig.2.27.

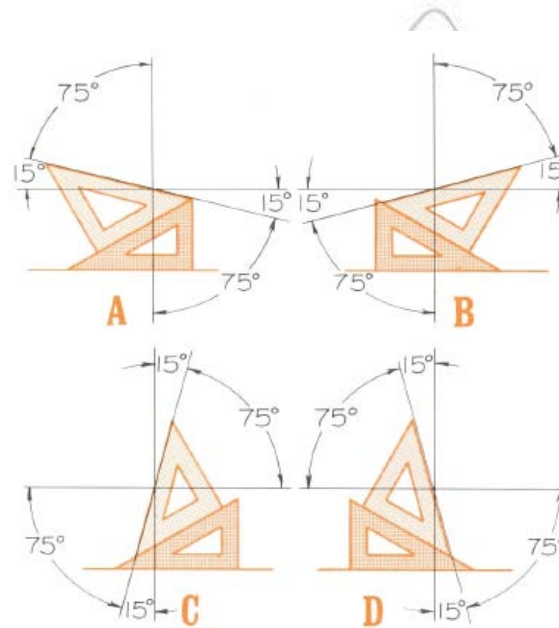

Fig. 2.27. Inclined lines using 45° & $30-60^\circ$ set squares

Key terms

International organization for standardization (ISO):

This organization publishes documents that define procedures and specifications for a range of materials, processes and services.

Checkpoint 2.1: Drawing horizontal and vertical lines

1. Fasten a drawing paper of size A4 to the drawing border.
2. Draw the border lines as follows:
 - a. Measure a distance of 1cm in front of each edge of the paper and put marks using the 5H pencil.
 - b. Draw light horizontal lines parallel to the upper and lower edges of the paper through the marks using the 5H pencil.
 - c. Draw two light vertical lines parallel to the left and right edges of the paper through the other marks using 5H pencil.
 - d. Finally, go over the line using the HB pencil to get dark border lines neatly terminating at each corner.
3. Working downwards from the upper border line, measure and mark a series of 2cm divisions on the left vertical border line. using the 5H pencil, draw light, thin horizontal lines through these divisions marks extending across the entire sheet between the border lines.
4. Working across from the left to the right border line, set off a series of 2cm divisions marks on the upper horizontal border line. Draw a series of light, thin vertical lines through these divisions marks extending upward across the entire paper between the border lines.
5. In a similar manner to steps 3 and 4, lay off a series of 1cm divisions on the upper horizontal and left vertical border lines. Then, through these division points, use your H pencil to draw dark horizontal and vertical lines between the lines drawn in steps 3 and 4. Your final drawing should now consist of a checkerboard pattern of parallel horizontal and vertical lines, alternatively light and dark, 1cm apart.

2.4.8 Drawing Circles and Arcs

The compass is used to draw circles and arcs. Before starting using a compass make sure that the compass is rigid enough not to swing inward or outward while drawing a circle.

To draw a circle or an arc follow these steps:

- Draw two perpendicular center lines of the circle.
- Set off the required radius on one of the center lines.
- Place the needle point at the intersection point of the center lines.
- Adjust the compass to the required radius.
- Lean or incline the compass forward slightly.

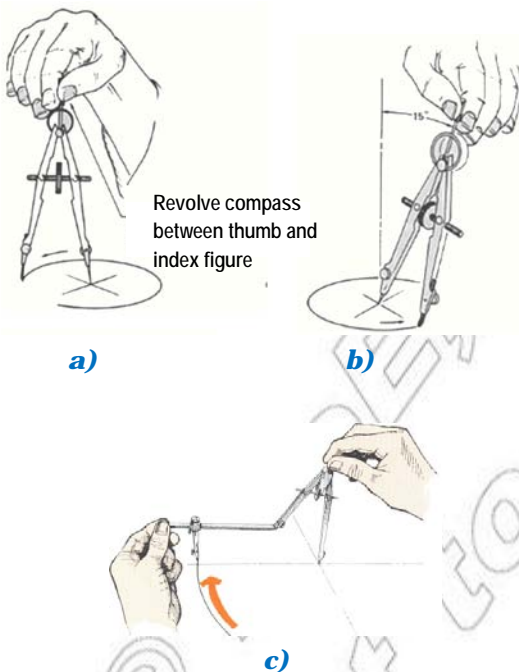

Fig. 2.28 Drawing circles using bow compass.

2.4.9 Using the Divider

The two main purposes of a divider are:

- i) To divide a line into equal parts by trial and error.
- ii) To transfer a distance from one part of a drawing to another.

Fig.2.29 shows how to use the divider to divide a line into equal parts. As an example assume the straight line XY is to be divide into five equal parts. A trial and error procedure is followed. First set the distance between the divider points to be one-fifth of the total distance XY approximately. Then step off this distance over the distance XY.

If an error OP shown in Fig.2.29 occurs widen the distance between the divider points by one-fifth of the error and step off. Repeat this procedure until the correct divisions are established.

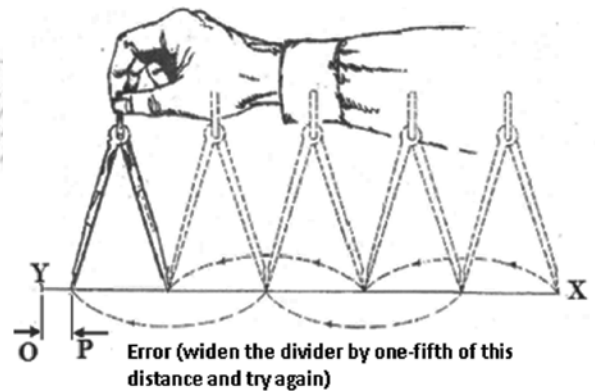

Fig. 2.29 Using the divider to divide a line into equal parts

2.4.10 Using French Curve

Curves other than circles and arcs are called irregular curves. French curves are used to draw irregular curves of various kind. When using the French curves to draw irregular curves, the following steps are recommended:

1. Plot all the points you wish to connect.
2. Sketch a very light line connecting all this points.
3. Place the French curve so that you align as many points as possible with the curvature of the French curve in the direction the curvature of the curve to be drawn increases. At least four points need to be align except for the end spaces.
4. Draw the line connecting these points except for the space at each end.
5. Reposition the French curve so that the first space aligned overlaps with the end space drawn last. Continue this procedure until the curve is drawn.

Note that when drawing symmetrical curves, such as ellipses, the same portion of the French curve should be used on all similar parts of the curve to be drawn

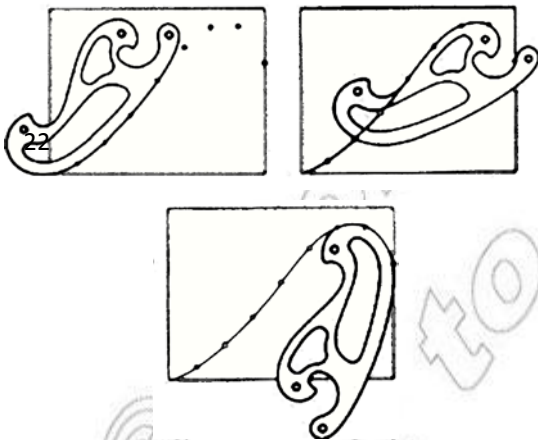

Fig. 2.30 Using the French curve

Activity 2.4

- On a short bond paper follow the format below and make your stand on what to do and not to do with your drafting tools and instruments by listing the DO's and DON'Ts on its proper corner.

Make a Stand!

What to do

How to take care of my tool and instrument

What note to do

Cautions in the use of instruments

To complete this discussion of instruments, here are a few points worth noting:

- Never use the scale as a ruler for drawing lines.
- Never draw horizontal lines with the lower edge of the T-square.
- Never use the lower edge of the T-Square as a horizontal base for the triangles.
- Never cut paper with a knife and the edge of the T- square as a guide.
- Never use the T-square as a hammer
- Never put either end of a pencil into the mouth.
- Never work with a dull pencil.
- Never sharpen a pencil over the drawing board.
- Never suite pointed end of the dividers into the drawing board.
- Never oil the joints of compasses.

- Never use the dividers as reamers, pincers, or picks.
- Never hold the pen over the drawing while filling.
- Never scrub a drawing all over with an eraser after finishing. It takes the life out of the lines.
- Never begin work without wiping off the table and instruments.
- Never put instruments away without cleaning them. This applies with particular force to pens.
- Never put bow instruments away without opening to relieve the spring.
- Never work on a table cluttered with unneeded instruments or equipment.
- Never fold a drawing or tracing paper.

2.4.11 Keeping Drawings Clean

Cleanliness in drawing is very important and should become a habit. The student should learn the factors involved. First, the draftsman should keep his hands clean at all times. Second, all drafting equipment, such as drawing board, T-square, triangles, and scale, should be cleaned frequently. Third, the largest contributing factors to dirty drawings is *not dirt, but graphite* from the pencil; hence the draftsman should practice the following Do's. (Fig. 2.31)

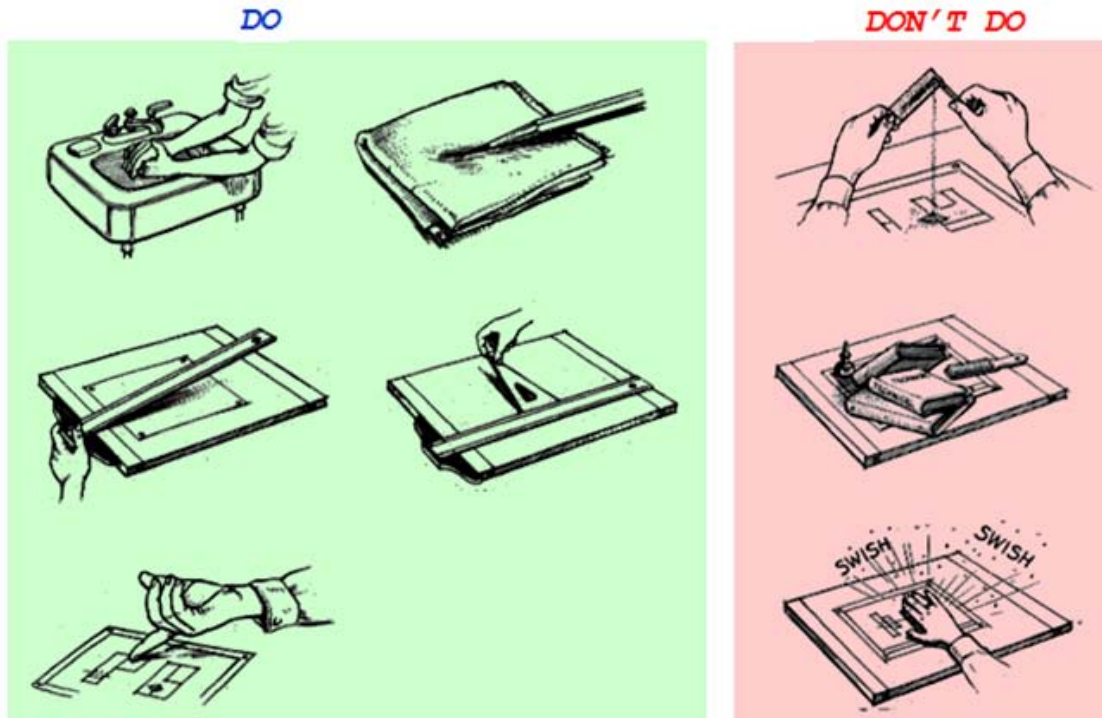

Fig. 2.31 To keep your drawing clean

2.4.12 Title Block

The primary purpose of a drawing title block is to identify a drawing. Title blocks must be uniform in size and easy to read. They may be mechanically lettered, neatly lettered freehand, or preprinted commercially on standard size drafting sheets.

Generally, the title block is placed in the lower right-hand corner of the drawing sheet, regardless of the size of the drawing (except for vertical title block). The arrangement and size of the title block are optional, but the following information should be included:

- the name of the company or organization.
- the title of the drawing.
- the drawing number, which is generally a unique filing identifier.

- the scale.
- the angle of projection used, either first or third, generally shown symbolically.
- the signature or initials of the draftsman, checker, approving officer, and issuing officer, with the respective dates.
- other information as required.

Provision may also be made within the title block for the date of issue, signatures, approvals, sheet number, drawing size, job, order, or contract number, references to this or other documents; and standard notes such as tolerances or finishes.

An example of a typical title block is shown in Fig.2.32. In class rooms, a title stripe is often used on A- and B-size drawings, such as shown in Fig. 2.33.

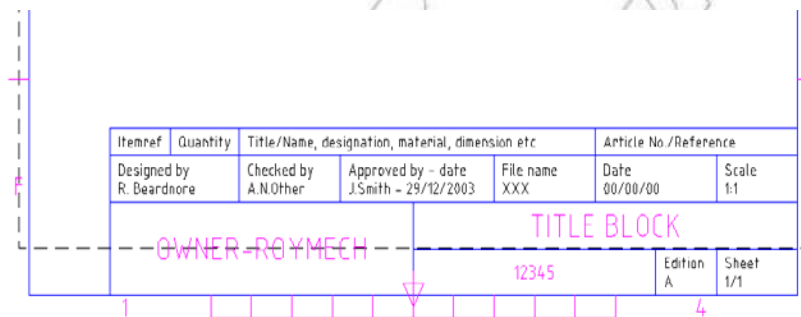

Fig. 2.32 Typical example of title block

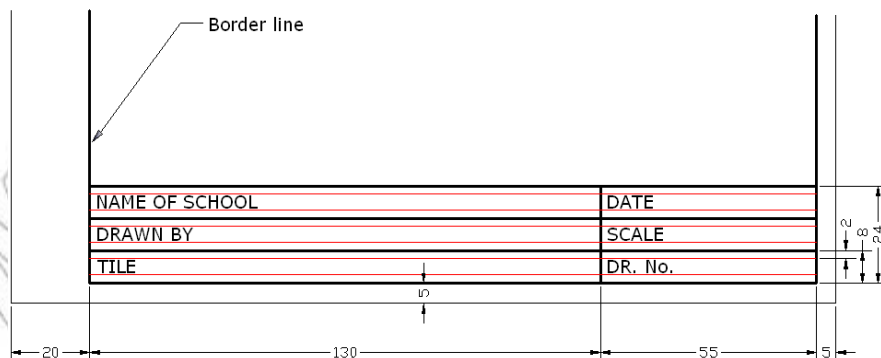

Fig. 2.33 School title block

UNIT SUMMARY

Technical drawing must be prepared in such a way that they are clear, concise, and accurate. In order to produce such drawings equipments (i.e. materials and instruments) are used.

The basic drawing materials which are necessary to prepare a technical drawing are:- Drawing paper, Drawing Pencil, Drafting or masking tape, Eraser, erasing shield, Rapidograph.

A clear understanding of all drawing instruments and their proper uses is important to speed up the process of drawing preparation. It is believed that “a design is as good as its instruments”.

Drawing boards are available in a variety of styles and sizes. Most are adjustable up and down, and can tilt to almost any angle from vertical 90° to horizontal. The drawing surface must be clean, flat, smooth, and large enough to accommodate the drawing and some drafting equipment. If a T-square is to be used, at least one edge on the board must be absolutely true.

T-square provides a parallel straight edge for the beginning drawing drafter. It is composed of two parts: the head and the blade. The two parts are fastened together at an exact right angle. The blade must be straight and free of any necks and imperfections. Draw lines using T-square only against the upper edge of the blade. Make sure the head is held against the left edge of the drawing board to guarantee parallel lines.

A compass is used mainly to draw circles and circular curves of relatively short radius. The large compass is satisfactory for drawing circles of 25 mm to about 300 mm in diameter without an extension bar.

The other type of compass is the bow compass. Many experienced draftsmen prefer the bow compass. The bow compass is much sturdier and is capable of taking the heavy pressure necessary to produce opaque pencil lines without losing the radius setting.

Dividers are similar to compasses, except that both legs are provided with needle points. Dividers are used to transfer measurements. To step off a series of equal distances, and to divide lines into a number of equal parts.

Triangles are used in combination with the T-square to draw vertical and inclined

lines. They are usually made of transparent plastic, which allows you to see your work underneath the triangles. Two standard triangles are used by the drafters. One is the 30-60° triangle. The other is the 45-degree triangle.

The adjustable triangle combines the functions of the triangle and the protractor. When it is used as a right triangle, the hypotenuse can be set and locked at any desired angle to one of the bases. The transparent protractor portion is equivalent to a protractor graduated in 1/2° increments.

A template is a thin, flat piece of plastic containing various cutout shapes. It is designed to increase the speed and accuracy of the drafter. Templates are available for drawing circles, ellipses, plumbing fixtures, bolts, nuts, screw threads, electronic symbols, springs, gears and much more. A template should be used whenever possible to increase the accuracy and the speed.

French curves are thin plastic tools that come in assortment of curved surfaces. They are used to produce curved lines that cannot be made by a compass. Most common French curves are actually segments of ellipses, parabolas and hyperbolas.

Protractors are used for measuring and laying off angles other than those that may be drawn with the triangle or a combination of triangles. Like the triangle, most protractors are made of transparent plastic. They are either circular or semicircular in shape.

An erasing shield restricts the erasing area so that the correctly drawn lines will not be disturbed during the erasing procedure. It is made from a thin flat piece of metal with variously sized cutouts. The shield is used by placing it over the line to be erased and erasing through the cutout.

Before starting the drawing you have to fulfill the following points:

- ☞ Make sure that all the necessary drawing instruments are ready and clean.
- ☞ Position your drawing board to minimize effects of shadows.
- ☞ Clean your drawing board.

Exercise I: Redraw the following figures in full scale.

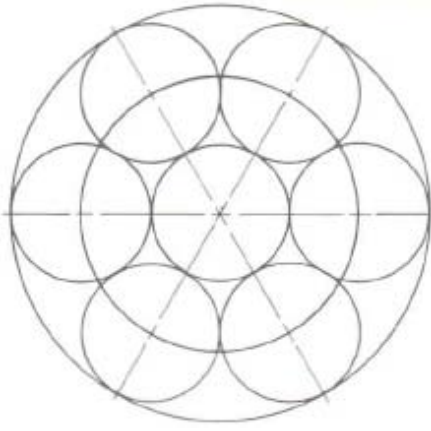

a)

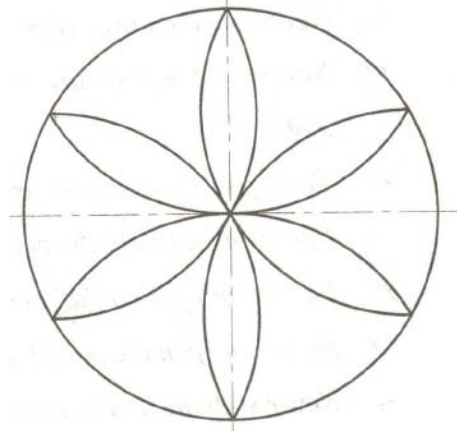

c)

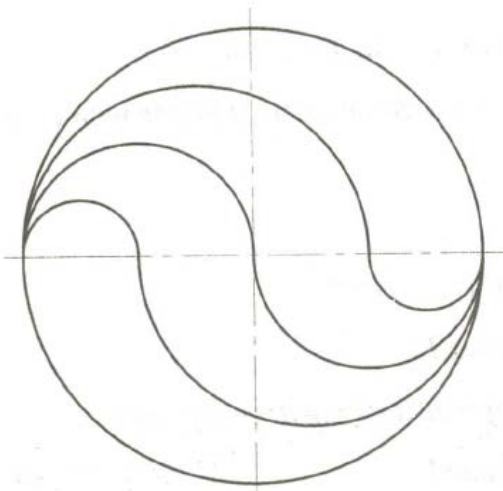

b)

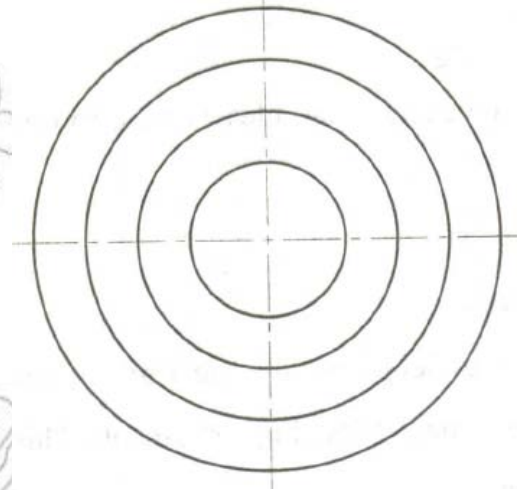

d)

Exercise II: Redraw the following figures in full scale.

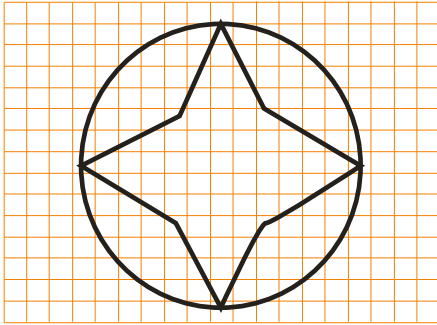

a)

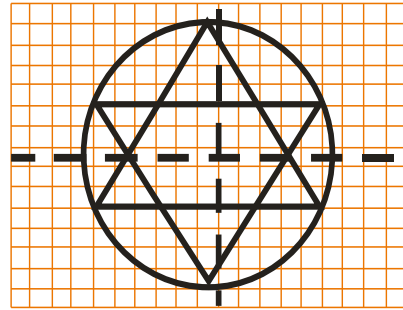

d)

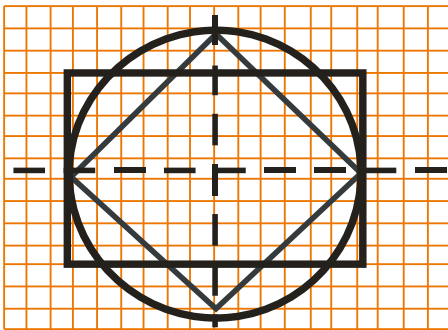

b)

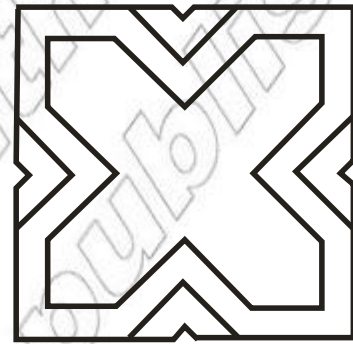

e)

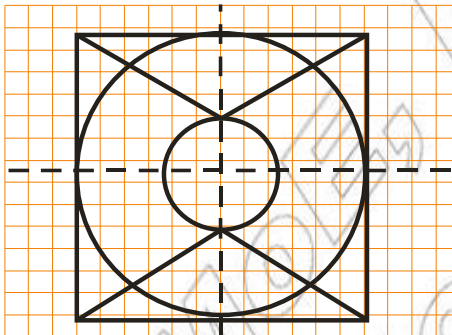

c)

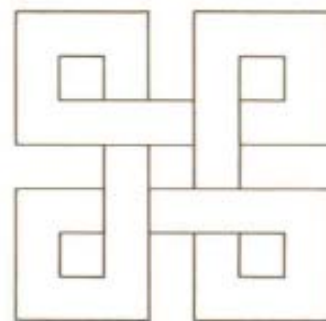

f)

© MOE, FDR Ethiopia
Not to be republished

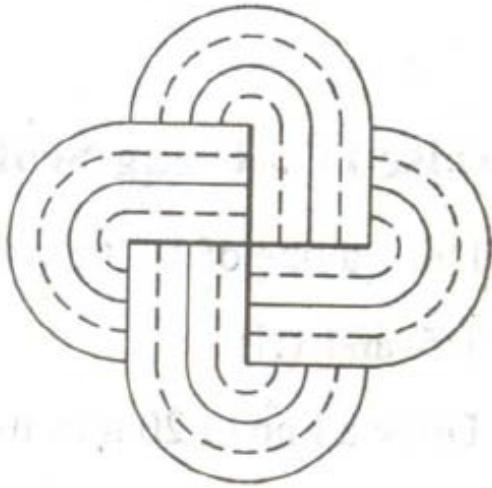

g)

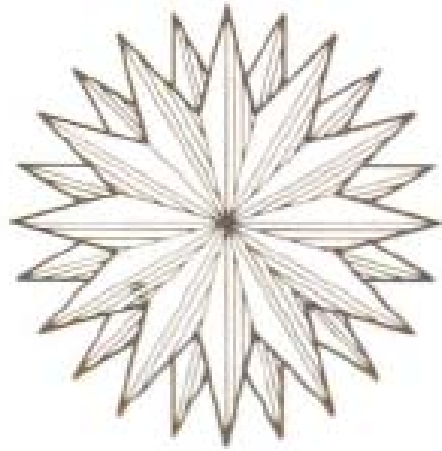

h)

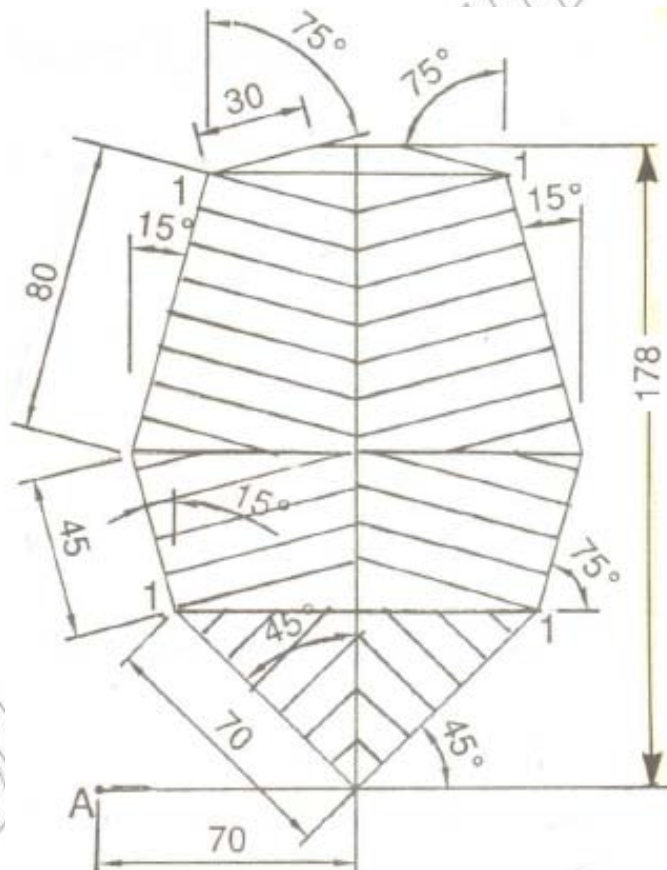

i)

Exercise III: Dividing a circle into equal number of parts.

1. Draw a circle of radius 50mm. Use an H lead in the compass.
2. Divide the circle drawn in step 1 into 24 equal parts using set-squares and the T-square as shown below. Use an H pencil. *Do not use protractor.*

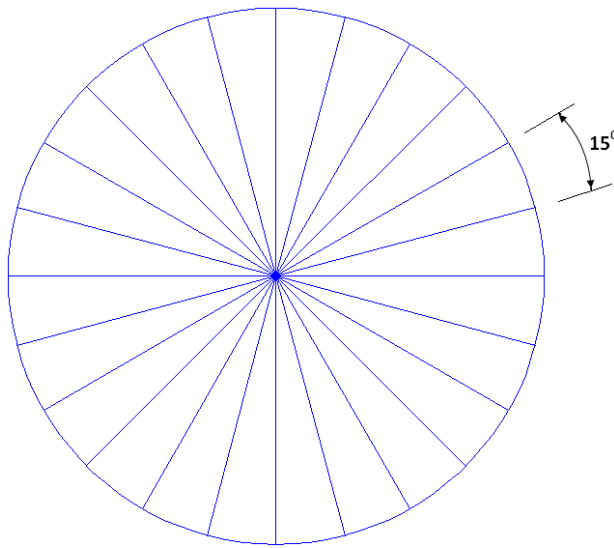

Exercise Iv: Using Scales.

1. Draw a line of 200mm full length. Then redraw the line to the following scales, 1:2, 1:5 and 1:10.
2. Draw a line of 10mm full length. Then redraw the line to the following scales: 2:1, 5:1, and 10:1.
3. Construct a circle whose full diameter is 150mm. Then, using the same center, redraw the circles to the following scales: 1:2, 1:5, and 1:10.
4. Draw a circle whose full radius is 10mm. Then, using the same center, redraw the circles to the following scales: 2:1, and 5:1.