

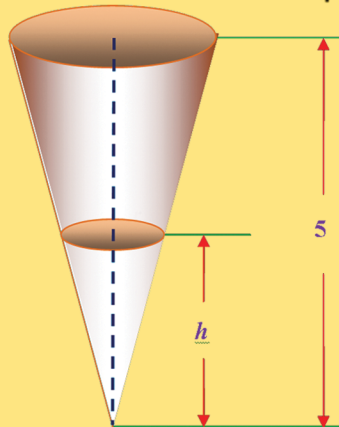

MATHEMATICS

STUDENT TEXTBOOK Grade 12

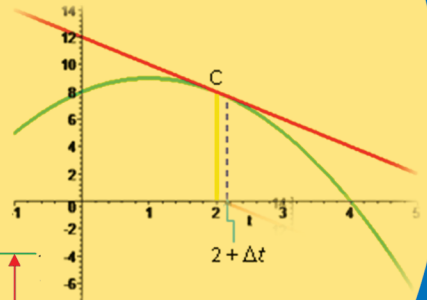
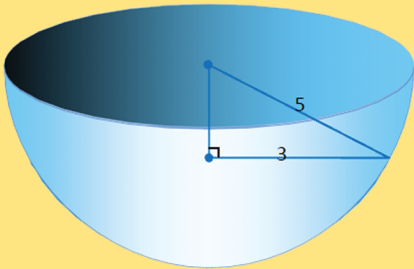
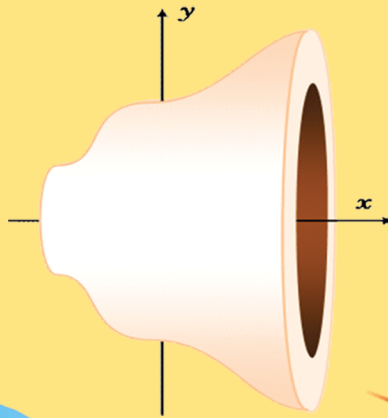

FEDERAL DEMOCRATIC REPUBLIC OF ETHIOPIA
MINISTRY OF EDUCATION



MATHEMATICS

STUDENT TEXTBOOK Grade 12

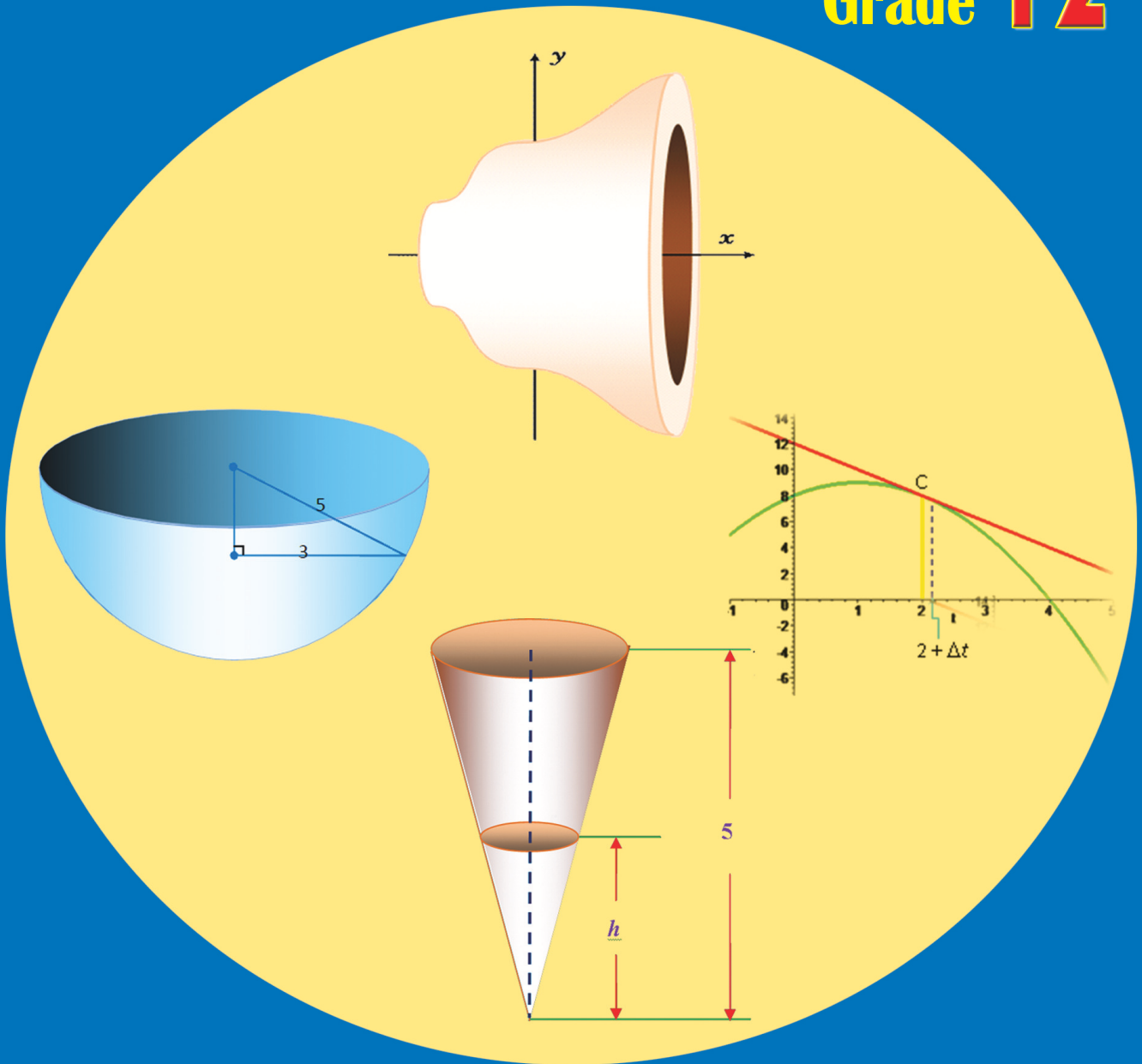

FEDERAL DEMOCRATIC REPUBLIC OF ETHIOPIA
MINISTRY OF EDUCATION

Take Good Care of This Textbook



This textbook is the property of your school.

Take good care not to damage or lose it.

Here are 10 ideas to help take care of the book:

1. Cover the book with protective material, such as plastic, old newspapers or magazines.
2. Always keep the book in a clean dry place.
3. Be sure your hands are clean when you use the book.
4. Do not write on the cover or inside pages.
5. Use a piece of paper or cardboard as a bookmark.
6. Never tear or cut out any pictures or pages.
7. Repair any torn pages with paste or tape.
8. Pack the book carefully when you place it in your school bag.
9. Handle the book with care when passing it to another person.
10. When using a new book for the first time, lay it on its back. Open only a few pages at a time. Press lightly along the bound edge as you turn the pages. This will keep the cover in good condition.



MATHEMATICS

STUDENT TEXTBOOK

GRADE 12

Authors, Editors and Reviewers:

Rachel Mary Z. (B.Sc.)
Kinfegabrail Dessalegn (M.Sc.)
Kassa Michael (M.Sc.)
Mezgebu Getachew (M.Sc.)
Semu Mitiku (Ph.D.)
Hunduma Legesse (M.Sc.)

Evaluators:

Tesfaye Ayele
Dagnachew Yalew
Tekeste Woldetensai



FEDERAL DEMOCRATIC REPUBLIC OF ETHIOPIA
MINISTRY OF EDUCATION



Published E.C. 2002 by the Federal Democratic Republic of Ethiopia, Ministry of Education, under the General Education Quality Improvement Project (GEQIP) supported by IDA Credit No. 4535-ET, the Fast Track Initiative Catalytic Fund and the Governments of Finland, Italy, Netherlands and the United Kingdom.

© 2010 by the Federal Democratic Republic of Ethiopia, Ministry of Education. All rights reserved. No part of this book may be reproduced, stored in a retrieval system or transmitted in any form or by any means including electronic, mechanical, magnetic or other, without prior written permission of the Ministry of Education or licensing in accordance with the Federal Democratic Republic of Ethiopia, *Federal Negarit Gazeta*, Proclamation No. 410/2004 – Copyright and Neighbouring Rights Protection.

The Ministry of Education wishes to thank the many individuals, groups and other bodies involved – directly and indirectly – in publishing this textbook and the accompanying teacher guide.

Copyrighted materials used by permission of their owners. If you are the owner of copyrighted material not cited or improperly cited, please contact with the Ministry of Education, Head Office, Arat Kilo, (PO Box 1367), Addis Ababa, Ethiopia.

PHOTO CREDIT: p.8, p.21, p.95, p.108 and p.369-Encarta®Encyclopedia, 2009 edition.
p.313-http:// www.pucrs.br

Developed and Printed by

STAR EDUCATIONAL BOOKS DISTRIBUTORS Pvt. Ltd.

24/4800, Bharat Ram Road, Daryaganj,

New Delhi – 110002, INDIA

and

ASTER NEGA PUBLISHING ENTERPRISE

P.O. Box 21073

ADDIS ABABA, ETHIOPIA

under GEQIP Contract No. ET-MoE/GEQIP/IDA/ICB/G01/09.

ISBN 978-99944-2-048-3

Contents

Unit 1 Sequences and Series 1

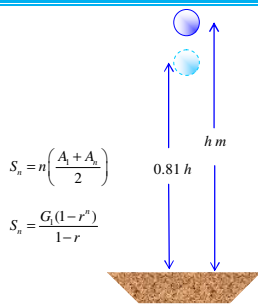

- 1.1** Sequences..... **3**
- 1.2** Arithmetic sequences and geometric sequences..... **9**
- 1.3** The sigma notation and partial sums..... **17**
- 1.4** Infinities series **27**
- 1.5** Applications of arithmetic progressions and geometric progressions..... **32**
- Key Terms* **37**
- Summary* **37**
- Review Exercises on Unit 1* **38**

Unit 2 Introduction to Limits and Continuity..... 41

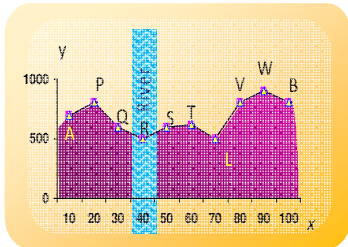

- 2.1** Limits of sequences of numbers **43**
- 2.2** Limits of functions..... **60**
- 2.3** Continuity of a function..... **76**
- 2.4** Exercises on applications of limits **92**
- Key Terms* **98**
- Summary* **98**
- Review Exercises on Unit 2* **100**

Unit 3

Introduction to Differential Calculus..... 103

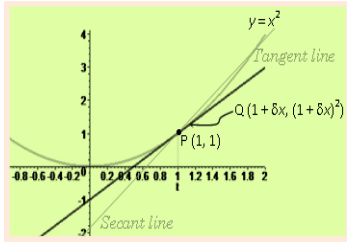

3.1	Introduction to Derivatives	104
3.2	Derivatives of some functions	121
3.3	Derivatives of combinations and compositions of functions	128
	<i>Key Terms</i>	155
	<i>Summary</i>	156
	<i>Review Exercises on Unit 3</i>	158

Unit 4

Applications of Differential Calculus 161

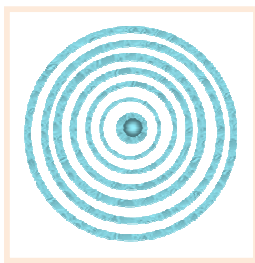

4.1	Extreme values of functions	163
4.2	Minimization and maximization problems...	189
4.3	Rate of change	197
	<i>Key Terms</i>	204
	<i>Summary</i>	204
	<i>Review Exercises on Unit 4</i>	206

Unit 5

Introduction to Integral Calculus 207

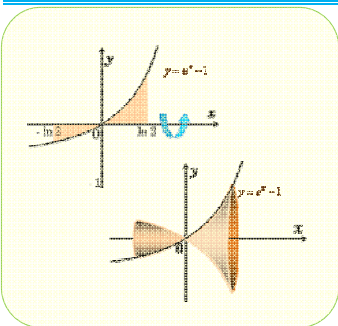

5.1	Integration as reverse process of differentiation.....	208
5.2	Techniques of integration	220
5.3	Definite integrals, area and fundamental theorem of calculus	233
5.4	Applications of Integral calculus	245
	<i>Key Terms</i>	266
	<i>Summary</i>	266
	<i>Review Exercises on Unit 5</i>	268

Unit 6

Three Dimensional Geometry and Vectors in Space (For Natural Science Students) 271

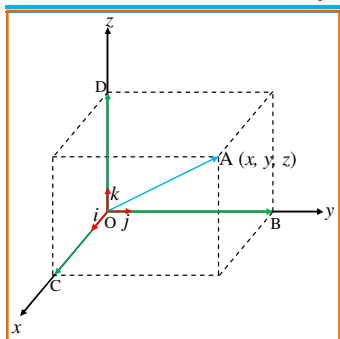

6.1	Coordinate axes and coordinate planes in space.....	272
6.2	Coordinates of a point in space	274
6.3	Distance between two points in space	276
6.4	Mid-point of a line segment in space.....	280
6.5	Equation of sphere.....	282
6.6	Vectors in space	285
	<i>Key Terms</i>	293
	<i>Summary</i>	293
	<i>Review Exercises on Unit 6</i>	294

Unit 7

Mathematical Proofs (For Natural Science Students) 296

p	q	$p \Rightarrow q$	$(p \Rightarrow q) \wedge \neg q$	$[(p \Rightarrow q) \wedge \neg q] \Rightarrow \neg p$
T	T	T	F	T
T	F	F	F	T
F	T	T	F	T
F	F	T	T	T

7.1	Revision on logic	297
7.2	Different types of proofs	307
7.3	Principle and application of mathematical induction.....	312
	<i>Key Terms</i>	317
	<i>Summary</i>	318
	<i>Review Exercises on Unit 7</i>	320

Unit 8

Further on Statistics

(For Social Science Students) 322

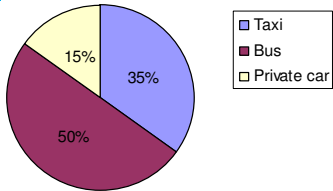

8.1	Sampling techniques	323
8.2	Representation of data	328
8.3	Construction and interpretation of graphs ..	332
8.4	Measures of central tendency and measures of variability	344
8.5	Analysis of frequency distributions.....	359
8.6	Use of cumulative frequency curves.....	362
	<i>Key Terms</i>	366
	<i>Summary</i>	366
	<i>Review Exercises on Unit 8</i>	368

Unit 9

Mathematical Applications for Business and

consumers (For Social Science Students) 370



9.1	Applications to purchasing	371
9.2	Percent increase and percent decrease.....	373
9.3	Real estate expenses	380
9.4	Wages	385
	<i>Key Terms</i>	389
	<i>Summary</i>	389
	<i>Review Exercises on Unit 9</i>	390
	Table of monthly payments	392
	Table of random numbers	393

Unit 1

SEQUENCES AND SERIES

$$S_n = n \left(\frac{A_1 + A_n}{2} \right)$$

$$S_n = \frac{G_1(1-r^n)}{1-r}$$

$$\sum_{n=1}^{\infty} n(n+1)$$

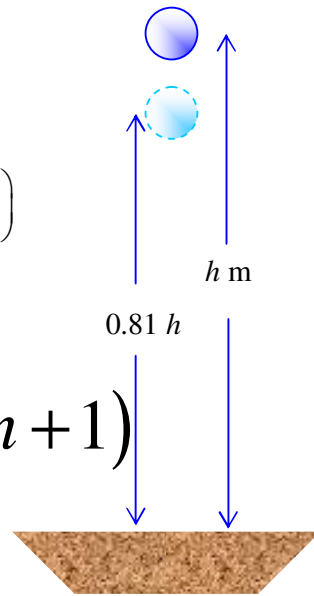

Unit Outcomes:

After completing this unit, you should be able to:

- *revise the notions of sets and functions.*
- *grasp the concept of sequence and series.*
- *compute any terms of sequences from given rule.*
- *find out possible rules (formulas) from given terms.*
- *identify the types of sequences and series.*
- *compute partial and infinite sums of sequences.*
- *apply the knowledge of sequence and series to solve practical and real life problems.*

Main Contents

1.1 SEQUENCES

1.2 ARITHMETIC SEQUENCE AND GEOMETRIC SEQUENCE

1.3 THE SIGMA NOTATION AND PARTIAL SUMS

1.4 INFINITE SERIES

1.5 APPLICATIONS OF SEQUENCE AND SERIES

Key terms

Summary

Review Exercises

INTRODUCTION

Much of the mathematics we are using today was developed as a result of modelling real world situations such as meteorology in the study of weather patterns, astronomy in the study of patterns of the movements of stars and galaxies and number sequences as patterns of numbers.

Studying about number sequences is helpful to make predictions in the patterns of natural events.

For instance, Fibonacci numbers, a series of numbers 1, 1, 2, 3, 5, 8, 13, 21, ... where each number is the sum of the two preceding numbers, is used in modelling the birth rates of rabbits.

In some number sequence, it is possible to see that the possibility of the sum of infinitely many non-zero numbers to be finite.

For example, is it possible to find the following sums?

a $1 + 2 + 3 + 4 + 5 + \dots + n + \dots$

b $1 + \frac{1}{2} + \frac{1}{3} + \frac{1}{4} + \frac{1}{5} + \dots + \frac{1}{n} + \dots$

c $1 + \frac{1}{2} + \frac{1}{4} + \frac{1}{8} + \frac{1}{16} + \dots + \frac{1}{2^{n-1}} + \dots$

d $1 + -1 + 1 + -1 + 1 + -1 + \dots + (-1)^{n-1} + \dots$

This concept, which may seem paradoxical at first, plays a central role in science and engineering and has a variety of important applications.

One of the goals of this unit is to examine the theory and applications of infinite sums, which will be referred to as infinite series. We will develop a method which may help you to determine whether or not such an infinite series has a finite sum.



OPENING PROBLEM

A farmer has planted certain trees on a piece of land. The land is in the form of an isosceles triangular region with base 100 m and height 50 m. The trees are grown up in different rows as shown in **Figure 1.1**.

In each row, the distance between any two adjacent trees is 5 m. The distance between any two consecutive rows is 5 m, too.

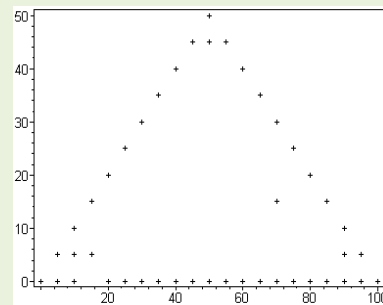

Figure 1.1

- a** How many rows of trees are there on the piece of land?
- b** How long is each row?
- c** How many trees are there in each row?
- d** What is the total number of trees on the piece of land?

To solve problems like this and many others, a detailed study of sequences and their sums (called **series**) is required.

1.1 SEQUENCES

1.1.1 Revision on Sets and Functions

ACTIVITY 1.1



From your previous knowledge of sets and functions, answer the following questions, discussing each point with your partner and /or teacher.

- 1** Define and discuss each of the following terms by producing examples.
 - a** Set **b** Finite set **c** Infinite set
 - d** Equal and equivalent sets **e** Countable set
- 2** Define a one-to-one function on the set of natural numbers onto each of the following sets:
 - a** The set of whole numbers **b** The set of integers
 - c** The set of even integers
- 3** Show that the sets in **2 a, b** and **c** are equivalent to the set of natural numbers.
- 4** Let S be the set of the first 10 prime numbers. Define a function

$$f: S \rightarrow \mathbb{N} \text{ by } f(n) = n^2 - 2.$$
 - a** What is the domain of f ? **b** What is the range of f ?
 - c** Draw the graph of f .
- 5** Consider the **Pascal's triangle**.

row 1			1				
row 2			1		1		
row 3		1		2		1	
row 4	1		3		3		1

Let $f(n)$ be the sum of the numbers in the n^{th} row.

For example $f(1) = 1$, $f(2) = 1 + 1 = 2$, $f(3) = 1 + 2 + 1 = 4$.

- a** Evaluate $f(10)$, $f(15)$ and $f(n)$.

- b** Plot the points with coordinates $(n, f(n))$ for $n = 1, 2, 3, 4, 5, 6$ on a coordinate plane.
- 6** Let f be a function defined on \mathbb{N} by $f(n) = \frac{n!}{2^n}$. Evaluate
- a** $f(1)$ **b** $f(5)$ **c** $f(10)$
- 7** Define q on \mathbb{N} by $q(n) =$ the integral factors of n .
Plot the points with coordinates $(n, q(n))$ for $n = 1, 2, 3, 4, 5, 6$ on a coordinate plane.

1.1.2 Number Sequences

The word sequence, used in everyday conversation, usually refers to a list of things occurring in a specific order. In mathematics, a sequence is viewed as a set of numbers one comes after another in a given rule.

Recognizing and identifying patterns is a fundamental idea that appears in science and mathematics. It serves as a fruitful starting point for analysing a wide variety of problems.

Sequences arise in many different ways. For example, consider the following activities and try to get the patterns.

ACTIVITY 1.2

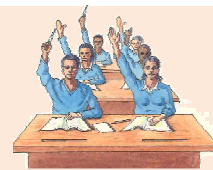

- 1** The monthly rent of a machine, Birr 200, is to be paid at the end of each month. If it is not paid at the end of the month, the amount due will increase Birr 3 per day.

What will be the amount to be paid after a delay of

- a** 3 days? **b** 10 days? **c** n days?
- 2** What do you understand about a sequence?
- 3** Consider the function a given by

$$a(n) = 3n - 1,$$

where the domain of a is the set of natural numbers \mathbb{N} .

Then $a(1) = 2, a(2) = 5, a(3) = 8, \dots$

The function a is an example of a sequence.

Instead of the standard function notation, sequences are usually defined using special notation. The value $a(n)$ is usually symbolized as a_n .

Thus, we have $a_n = 3n - 1$.

The elements in the range of a_n are called the **terms of the sequence**; a_1 is the first term, a_2 is the second term, and a_n is **the n^{th} term**, or **the general term of the sequence**.

Evaluate: a_{10}, a_{15} and a_{25}

In this section, we give the mathematical definition of a number sequence.

Definition 1.1

A sequence $\{a_n\}$ is a function whose domain is the set of positive integers or a subset of consecutive positive integers starting with 1.

The functional values: $a_1, a_2, a_3, \dots, a_n, \dots$ are called the **terms of a sequence**, and a_n is called the **general term**, or the n^{th} term of the sequence.

We usually write a_n instead of the function $a(n)$ for the value of the function at the number n , if $n \in \mathbb{N}$.

NOTATION

The sequence $\{a_1, a_2, a_3, \dots, a_n, \dots\}$ is also denoted by $\{a_n\}$ or $\{a_n\}_{n=1}^{\infty}$

Sequences can be described by;

- | | | | |
|------------|--------------------|-----------|-----------------------------|
| i | listing the terms. | ii | writing the general term. |
| iii | drawing graphs. | iv | using recurrence relations. |

Example 1

- a** By associating each positive integer n , with its reciprocal, $\frac{1}{n}$, we obtain a

sequence denoted by $\left\{\frac{1}{n}\right\}$ which represents the sequence of numbers

$$1, \frac{1}{2}, \frac{1}{3}, \frac{1}{4}, \frac{1}{5}, \dots, \frac{1}{n}, \dots$$

The general term is $a_n = \frac{1}{n}$.

- b** Given the general term $a_n = \left(\frac{1}{2}\right)^{n-1}$, we obtain

$$a_1 = 1, a_2 = \frac{1}{2}, a_3 = \frac{1}{4}, a_4 = \frac{1}{8} \text{ and so on. List up to the } 10^{\text{th}} \text{ term.}$$

- c** Given certain terms of a sequence, say 2, 4, 6, 8, ..., which one of the following is the possible general term?

$$a_n = 2n \text{ or } a_n = (n-1)(n-2)(n-3)(n-4) + 2n \text{ for } n \text{ a positive integer.}$$

Both general terms have the same first four terms; but they differ by fifth term. Try to find the fifth and sixth terms for both general terms.

Example 2 Write a formula for the general term of each of the sequences.

- a** 1, 4, 9, 16, 25, 36, 49, 64, 81, 100, ... **b** $-\frac{1}{2}, \frac{1}{4}, -\frac{1}{8}, \frac{1}{16}, \dots$

- c** 2, 0, 2, 0, 2, 0, ... **d** 2, 7, 24, 77, ... **e** 1, 3, 6, 10, ...

Solution To write a formula for the n^{th} term of a sequence, examine the terms and look for the pattern. Each of you may come with several formulae; the following are few of them.

- a** $a_n = n^2$ **b** $a_n = \left(-\frac{1}{2}\right)^n$ **c** $a_n = 1 - (-1)^n$
d $a_n = 3^n - n$ **e** $a_n = \frac{n}{2}(n+1)$

Some sequences are defined by giving a formula for the n^{th} term:

Example 3

- a** For the sequence $\left\{\frac{n}{n+1}\right\}_{n=1}^{\infty}$, the general term is $a_n = \frac{n}{n+1}$ and terms of the sequence can be given as $\frac{1}{2}, \frac{2}{3}, \frac{3}{4}, \frac{4}{5}, \dots, \frac{n}{n+1}, \dots$
b For the sequence $\left\{\frac{(-1)^n}{n}\right\}_{n=1}^{\infty}$, the general term is $a_n = \frac{(-1)^n}{n}$ and terms of the sequence can be given as $-1, \frac{1}{2}, \frac{-1}{3}, \frac{1}{4}, \dots, \frac{(-1)^n}{n}, \dots$

Graphically, this sequence is described in the figure below.

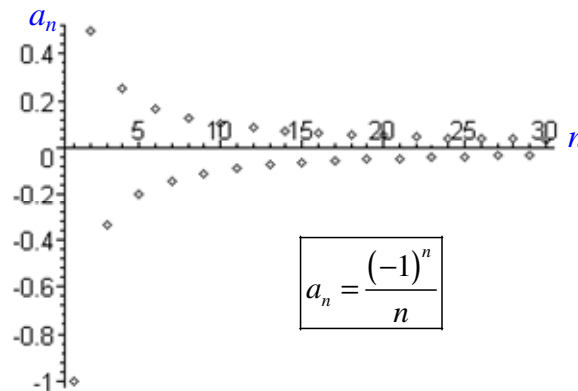

Figure 1.2

- c** For the sequence $\left\{\sin\left(\frac{n\pi}{3}\right)\right\}_{n=1}^{\infty}$ the general term is $a_n = \sin\left(\frac{n\pi}{3}\right)$ and terms of the sequence can be given as $\frac{\sqrt{3}}{2}, \frac{\sqrt{3}}{2}, 0, -\frac{\sqrt{3}}{2}, -\frac{\sqrt{3}}{2}, 0, \dots, \sin\left(\frac{n\pi}{3}\right), \dots$

Note:

- ✓ A sequence that has a last term is called a **finite sequence**. A sequence that does not have a last term is called an **infinite sequence**. The domain of a finite sequence is $\{1, 2, 3, \dots, n\}$. The domain of an infinite sequence is \mathbb{N} .

For instance, $1, 2, 3, \dots, 10$ is a finite sequence and $1, 2, 3, \dots$ is an infinite sequence. Some sequences do not have a simple defining formula.

Example 4

- a** The sequence, $\{p_n\}$, where p_n is the population of Ethiopia as of Meskerem 1 in the year n .
- b** If we let a_n to be the digit in the n^{th} decimal place of the number $\sqrt{2}$, then $\{a_n\}$ is a well defined sequence whose first few terms are $4, 1, 4, 2, 1, 3, 5, \dots$.

Recursion Formula

A formula that relates the general term a_n of a sequence to one or more of the terms that come before it is called a **recursion formula**. A sequence that is specified by giving the first few terms together with a recursion formula is said to be defined recursively.

Example 5 Find the first six terms of the sequence $\{a_n\}$ defined recursively by $a_1 = 2$

$$\text{and } a_n = \frac{a_{n-1}}{n} \text{ for } n \geq 2.$$

Solution

$$a_1 = 2, \quad a_2 = \frac{a_1}{2} = \frac{2}{2} = 1, \quad a_3 = \frac{a_2}{3} = \frac{1}{3}, \quad a_4 = \frac{a_3}{4} = \frac{\frac{1}{3}}{4} = \frac{1}{12}$$

$$a_5 = \frac{a_4}{5} = \frac{\frac{1}{12}}{5} = \frac{1}{60}, \quad a_6 = \frac{a_5}{6} = \frac{\frac{1}{60}}{6} = \frac{1}{360}$$

Thus, the first six terms of the sequence $\{a_n\}$ are $2, 1, \frac{1}{3}, \frac{1}{12}, \frac{1}{60}, \frac{1}{360}$.

Note:

- ✓ The values of recursively defined functions are calculated by the repeated application of the function to its own values.

Example 6 The Fibonacci sequence f_n is defined recursively by the conditions

$$f_1 = 1, \quad f_2 = 1, \quad f_n = f_{n-1} + f_{n-2} \text{ for } n \geq 3.$$

Solution Each term is the sum of the two preceding terms.

The sequence described by its first few terms is

$$\{1, 1, 2, 3, 5, 8, 13, 21, 34, 55, \dots\}.$$



HISTORICAL NOTE

Leonardo Fibonacci (circa 1170, 1240)

Italian mathematician *Leonardo Fibonacci* made advances in number theory and algebra. Fibonacci, also called Leonardo of Pisa, produced numbers that have many interesting properties such as the birth rates of rabbits and the spiral growth of leaves on some trees.



He is especially known for his work on series of numbers, including the Fibonacci series. Each number in a Fibonacci series is equal to the sum of the two numbers that came before it. Fibonacci sequence arose when he was trying to solve a problem of the following kind concerning the breeding of rabbits.

“Suppose that rabbits live forever and that every month each pair produces a new pair which become productive at the age of two months. If we start with one new born pair, how many pairs of rabbits will we have in the n^{th} month?”

Verify that the answer to the above question is the Fibonacci sequence discussed in **Example 6** above.

Exercise 1.1

1 List the first five terms of each of the sequences whose general terms are given below, where n is a positive integer.

a $a_n = 1 - (0.2)^n$

b $a_n = \frac{n+1}{3n-1}$

c $a_n = \frac{3(-1)^n}{n}$

d $a_n = \cos\left(\frac{n\pi}{2}\right)$

e $a_1 = 1, a_{n+1} = \frac{1}{1+a_n}$

f $a_n = 2^n - 3n + 1$

g $a_n = (-1)^n + 1$

h $a_n = \frac{n^n}{n!}$

i $p_n =$ the n^{th} prime number.

j $q_n =$ the sum of the first n natural numbers.

k $a_1 = -1, a_2 = 2, a_{n+2} = na_1 + (n+1)a_2, n \geq 1$

l $a_1 = 1, a_{n+1} = \frac{1}{1+a_n^2}$ for $n \geq 1$.

2 Find a formula for the general term a_n of each of the following sequences, assuming that the pattern of the first few given terms continues.

a $\{3, 6, 9, 12, 15, \dots\}$

b $\{2, 7, 12, 17, \dots\}$

c $\{0, 2, 0, 2, 0, 2, \dots\}$

d $\left\{-\frac{1}{4}, \frac{2}{9}, -\frac{3}{16}, \frac{4}{25}, \dots\right\}$

e $\{2, 3, 5, 8, 13, 21, \dots\}$

f $\{1, -1, 1, -1, \dots\}$

g $\{0, 1, 3, 7, 15, \dots\}$

h $\left\{1, 2, \frac{3}{2}, \frac{2}{3}, \frac{5}{24}, \dots\right\}$

i $\{0.2, 0.22, 0.222, 0.2222, \dots\}$

j $\left\{\frac{1}{2}, \frac{2}{3}, 1, \frac{8}{5}, \frac{8}{3}, \frac{32}{7}, 8, \dots\right\}$

1.2

ARITHMETIC SEQUENCES AND GEOMETRIC SEQUENCES

1.2.1

Arithmetic Sequences



OPENING PROBLEM

100 students registered to take an exam were given cards with numbers ranging from 1 to 100. There were four exam rooms: R_1 , R_2 , R_3 and R_4 .

Students with card numbers

a $1, 4, 7, 10, \dots$ must be in R_1 ;

b $2, 5, 8, 11, \dots$ in R_2 ;

c $3, 9, 15, \dots$ in R_3 ;

d $6, 12, 18, 24, \dots$ in R_4 .

The numbers in each room continue with a constant difference.

1 Find the total number of students in each room.

2 Are there any students assigned to different rooms simultaneously? If so, which card numbers?

3 Are there students who are not assigned? If so, which card numbers?

ACTIVITY 1.3

1 Find the difference between consecutive terms for each of the sequences given below.

a $1, 3, 5, 7, 9, \dots$

b $10, 15, 20, 25, \dots$

c $10, 20, 30, 40, \dots$

d $1, -9, -19, -29, \dots$

2 Can you see ways of obtaining any terms in such a sequence, given the first term and the difference between consecutive terms?



Now, one can observe from the above **activity 1.3** that the difference between each pair of consecutive terms is a constant.

Definition 1.2

An **arithmetic sequence** (or **arithmetic progression**) is one in which the difference between consecutive terms is a constant. This constant is called the **common difference**. i.e., $\{A_n\}$ is an arithmetic sequence with common difference d , if and only if $A_{n+1} - A_n = d$ for all n .

From **Definition 1.2**, we observe that if $A_1, A_2, A_3, \dots, A_n, \dots$ is an arithmetic progression, then, $A_2 - A_1 = A_3 - A_2 = A_4 - A_3 = \dots = A_{n+1} - A_n = \dots = d$.

Equivalently, $A_2 = A_1 + d, A_3 = A_2 + d, A_4 = A_3 + d, \dots, A_{n+1} = A_n + d, \dots$

Hence, $A_2 = A_1 + d, A_3 = A_1 + 2d, A_4 = A_1 + 3d, \dots, A_{n+1} = A_1 + nd, \dots$

Thus, we have proved the following theorem for the general term A_n .

Theorem 1.1

If $\{A_n\}$ is an arithmetic progression with the first term A_1 and a common difference d , then the n^{th} term is given by

$$A_n = A_1 + (n-1)d.$$

Example 1 Given an arithmetic sequence with first term 5 and common difference 4, find the first five terms and the twentieth term.

Solution The first term of the arithmetic sequence is 5; hence $A_1 = 5$

$$A_2 = A_1 + d = 5 + 4 = 9 \qquad A_3 = A_1 + 2d = 5 + 2 \times 4 = 13$$

$$A_4 = A_1 + 3d = 5 + 3 \times 4 = 17 \qquad A_5 = A_1 + 4d = 5 + 4 \times 4 = 21$$

Thus, the first five terms are 5, 9, 13, 17, and 21.

To find the twentieth term, we can use the formula $A_n = A_1 + (n-1)d$

$$A_{20} = A_1 + 19d = 5 + 19 \times 4 = 81.$$

Example 2 Given an arithmetic sequence whose first two terms are -3 and 7 , find the next three terms and the fourteenth term.

Solution Since the first two terms of the sequence are -3 and 7 , we have $A_1 = -3$ and $A_2 = 7$; because the sequence is arithmetic

$$d = A_2 - A_1 = 7 - (-3) = 10$$

$$\text{Since } A_n = A_1 + (n-1)d, \qquad A_3 = A_1 + 2d = -3 + 2 \times 10 = 17$$

$$A_4 = A_1 + 3d = -3 + 3 \times 10 = 27 \qquad A_5 = A_1 + 4d = -3 + 4 \times 10 = 37$$

Therefore, the three terms following -3 and 7 are 17, 27 and 37.

The fourteenth term can be found by using the formula $A_n = A_1 + (n-1)d$

$$A_{14} = -3 + (14-1)10 = 127$$

Example 3 Show that the sequence $\{2n-3\}$ is an arithmetic sequence. Describe the sequence graphically.

Solution Let $A_n = 2n-3 \Rightarrow A_{n+1} = 2(n+1)-3 = 2n-1$

$$\Rightarrow A_{n+1} - A_n = (2n-1) - (2n-3) = 2, \text{ a constant for all natural numbers } n.$$

Thus, $\{2n-3\}$ is an arithmetic sequence.

If we plot the set of points whose coordinates are $\{(n, 2n-3) : n \in \mathbb{N}\}$, we get the graph of the sequence.

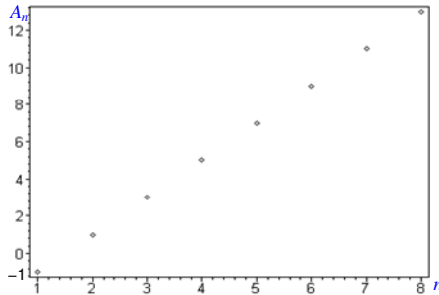

Figure 1.3

Observe that the graph follows the pattern of a linear function.

Example 4 A man bought a motor car for Birr 80,000. If the value of the car depreciates at the rate of Birr 7,000 per year, what is its value at the end of the 9th year?

Solution The present value of the car is Birr 80,000. The rate at which the value depreciates yearly is 7,000. Thus, the value at the end of the first year is

$$\text{Birr } 80,000 - \text{Birr } 7,000 = \text{Birr } 73,000.$$

The value at the end of the second year is $\text{Birr } 73,000 - \text{Birr } 7,000 = \text{Birr } 66,000$ and at the end of the third year it is $\text{Birr } 66,000 - \text{Birr } 7,000 = \text{Birr } 59,000$.

Thus, the values at the end of consecutive years form an arithmetic sequence.

$$73,000, 66,000, 59,000, \dots$$

$$\text{with } A_1 = 73,000 \text{ and } d = -7,000$$

$$\Rightarrow A_n = 73,000 - 7,000(n-1)$$

$$\Rightarrow A_9 = 73,000 - 7,000 \times 8$$

$$= 17,000$$

Therefore, the value of the motor car at the end of the 9th year is Birr 17,000.00.

ACTIVITY 1.4



- 1 If a , c , and b ; are three consecutive terms of an arithmetic sequence, then c is called the arithmetic mean between a and b .
 - a Express c in terms of a and b .
 - b Find the arithmetic mean between 10 and 15.
- 2 If $\{a, m_1, m_2, m_3, \dots, m_k, b\}$ is an arithmetic sequence, then we say that $m_1, m_2, m_3, \dots, m_k$ are k -arithmetic means between a and b .
 Insert 5 arithmetic means between 4 and 13.

Exercise 1.2

- 1 Determine whether the sequences with the following general terms are arithmetic.

a $a_n = 4n - 7$	b $a_n = 4n$	c $a_n = 5n + 3$
d $a_n = n^2 - n$	e $a_n = 5$	f $a_n = \frac{7-4n}{3}$
- 2 Consider the sequence 97, 93, 89, 85, ...
 - a Show that the sequence can be continued arithmetically.
 - b Find a formula for the general term.
 - c Is 60 a term in the sequence?
- 3 The n^{th} term of a sequence is given by $7n - 3$.
 - a Show that the sequence is arithmetic.
 - b Find the 75th term.
 - c What is the least term of the sequence greater than 528?
- 4 Given an arithmetic sequence with $A_3 = 12$ and $A_9 = 14$, find A_1 and A_{30} .
- 5 Given an arithmetic sequence with $A_4 = 8$ and $A_8 = 10$, find A_1 and the common difference d .
- 6 Given an arithmetic sequence with $A_4 = 5$ and $d = 6$, find A_1 and A_9 .
- 7 Given an arithmetic sequence with $A_{61} = 102$ and $d = -\frac{5}{3}$, find A_1 and A_{30} .
- 8 In an arithmetic sequence, if the p^{th} term is q and the q^{th} term is p , find the $(p + q)^{\text{th}}$ term.
- 9 Find the total number of whole numbers that are less than 1000 and divisible by 7.
- 10 If n -arithmetic means are inserted between a and b , express the common difference in terms of a and b .
- 11 A man accepts a position with an initial salary of Birr 18000.00 per year. If it is known that his salary will increase at the end of every year by Birr 1500.00, what will be his annual salary at the beginning of the 11th year?

1.2.2 Geometric Sequences



OPENING PROBLEM

The population of Ethiopia in 2001 EC was approximately 75 million. If the population is increasing at a rate of 2% each year,

- a** what will the Ethiopian population be in 2020?
- b** what is the doubling period of the population?

ACTIVITY 1.5



- 1** Find the ratio between consecutive terms in each of the following sequences.
 - a** 2, 4, 8, 16, 32, ...
 - b** 100, 10, 1, $\frac{1}{10}$, $\frac{1}{100}$, ...
 - c** -81, 27, -9, 3, -1, $\frac{1}{3}$, ...
 - d** $\frac{1}{2}$, $\frac{1}{4}$, $\frac{1}{8}$, $\frac{1}{32}$, ...
- 2** Can you see how to obtain any term in such sequences, given the first term and the ratio?

From **Activity 1.5**, you should have seen that the ratio between each consecutive terms is a constant.

Definition 1.3

A **geometric sequence** (or **geometric progression**) is one in which the ratio between consecutive terms is a non zero constant. This constant is called the **common ratio**. i.e., $\{G_n\}$ is a geometric sequence, if and only if

$$G_{n+1} = rG_n; r \in \mathbb{R} \setminus \{0\}. \text{ The common ratio, } r = \frac{G_{n+1}}{G_n} \text{ for all } n.$$

From the **Definition**, we observe that if $G_1, G_2, G_3, \dots, G_n, \dots$ is a geometric progression, then

$$\frac{G_2}{G_1} = \frac{G_3}{G_2} = \frac{G_4}{G_3} = \frac{G_5}{G_4} = \dots = \frac{G_n}{G_{n-1}} = \dots = r$$

Equivalently, $G_2 = rG_1, G_3 = rG_2, G_4 = rG_3, \dots, G_{n+1} = rG_n, \dots$

$$\text{Hence } G_2 = rG_1, G_3 = r^2G_1, G_4 = r^3G_1, \dots, G_{n+1} = r^nG_1, \dots$$

Thus, we have proved the following theorem for the general term G_n .

Theorem 1.2

If $\{G_n\}$ is a geometric progression with the first term G_1 and common ratio r , then the n^{th} term is given by $G_n = r^{n-1}G_1$

Example 5 Given the geometric progression 3, 6, 12, 24, ..., find the next three terms and the sixteenth term.

Solution Since we are given a geometric sequence, we first find the common ratio, r , which is $\frac{6}{3} = 2$. Note that we can use any two consecutive terms to find r .

Therefore, the term following 24 is $2 \times 24 = 48$,
 the term following 48 is $2 \times 48 = 96$
 and the term following 96 is $2 \times 96 = 192$.

The sixteenth term is found using the formula

$$G_n = r^{n-1}G_1$$

$$G_{16} = 2^{16-1} \times 3 = 2^{15} \times 3 = 98,304$$

Example 6 Find the seventh term of a geometric sequence whose first term is 6 and whose fourth term is $\frac{1}{36}$.

Solution First, you need to find the common ratio r , by using the formula

$$G_n = r^{n-1}G_1$$

$$G_4 = r^{4-1}G_1 \text{ where } G_1 = 6, \text{ and } G_4 = \frac{1}{36}$$

$$\frac{1}{36} = r^3 \times 6 \Rightarrow r^3 = \frac{1}{216}$$

This gives you $r = \frac{1}{6}$.

$$\text{Thus, } G_7 = \left(\frac{1}{6}\right)^6 (6) = \frac{1}{7,776}.$$

Example 7 A machine depreciates by $\left(\frac{1}{20}\right)^{\text{th}}$ of its previous value every year. If its original cost is Birr 100,000.00, find the value of the machine at the end of the 6th year.

Solution The value of the machine at the end of the first year

$$= \text{Birr } 100,000.00 - \text{Birr } \frac{100,000.00}{20} = \text{Birr } 100,000 \left(1 - \frac{1}{20}\right).$$

The value at the end of the second year

$$= \text{Birr } 100,000 \left(1 - \frac{1}{20}\right) - \text{Birr } \frac{100,000}{20} \left(1 - \frac{1}{20}\right)$$

$$= \text{Birr } 100,000 \left(1 - \frac{1}{20}\right)^2.$$

Similarly, the value at the end of the 3rd year

$$= \text{Birr } 100,000 \left(1 - \frac{1}{20}\right)^3.$$

The values of the machine at the end of every year form a geometric sequence

$$100,000 \left(1 - \frac{1}{20}\right), 100,000 \left(1 - \frac{1}{20}\right)^2, 100,000 \left(1 - \frac{1}{20}\right)^3, \dots$$

Thus, the value at the end of the 6th year

$$= \text{Birr } 100,000 \left(1 - \frac{1}{20}\right)^6 = \text{Birr } 73509.18906$$

ACTIVITY 1.6



- 1 If a, c, b are three positive consecutive terms of a geometric sequence, then c is called the geometric mean between a and b .
 - a Find an expression for c in terms of a and b .
 - b Find the geometric mean between 4 and 8.
- 2 If $\{a, m_1, m_2, m_3, \dots, m_k, b\}$ is a geometric sequence, then we say that $m_1, m_2, m_3, \dots, m_k$ are k -geometric means between a and b .
Insert three geometric means between 0.4 and 5.

Exercise 1.3

- 1 Decide whether or not each of the following sequences is geometric. For those that are geometric, determine the n^{th} term.

<p>a $1, -2, 4, -8, \dots$</p> <p>c $-2, 0, 2, 4, \dots$</p> <p>e $0.9, 0.99, 0.999, 0.9999, \dots$</p> <p>g $5 + \sqrt{5}, 1 + \sqrt{5}, \frac{5 + \sqrt{5}}{5}, \frac{1 + \sqrt{5}}{5}, \dots$</p>	<p>b $5, 5, 5, 5, 5, \dots$</p> <p>d $9, -3, 1, -\frac{1}{3}, \frac{1}{9}, \dots$</p> <p>f $2x, 4x^2, 8x^3, 16x^4, \dots; x \neq 0.$</p>
--	---
- 2 Given the geometric sequence $5, 15, 45, \dots$, find the next three terms and the tenth term.

- 3** Find the eighth term of the geometric sequence whose first term is 5 and whose fourth term is $\frac{1}{25}$.
- 4** Find the fifth term of the geometric sequence whose first term is 1 and whose fourth term is 343.
- 5** If x , $4x + 3$ and $7x + 6$ are consecutive terms of a geometric sequence, find the value(s) of x .

Puzzle

A building company organizes a society to invest money starting from the first day of a month. If the society invests 1 cent for the first day, 2 cents for the second day, 4 cents for the third day and so on, with everyday investment being twice that of the previous day, how much will they invest on the 30th day of the month? Calculate the total amount invested in the entire month.

Exercise 1.4

- 1** Determine whether the given sequence is arithmetic, geometric or neither.
- a** 4, 7, 10, 13, ... **b** 2, 6, 10, 14, 20, 26, ... **c** $\frac{1}{2}, \frac{5}{4}, 2, \frac{11}{4}, \dots$
- d** 1, 4, 9, 16, ... **e** 2, -4, 8, -16, ... **f** $\frac{4}{3}, 8, 48, \dots$
- g** $a_n = 5 - 2n$, where n is a positive integer.
- h** $a_n = \frac{1}{n}$, where n is a positive integer.
- i** $a_n = \frac{1}{n^2}$, where n is a positive integer.
- j** $a_n = \frac{4^n}{7^{n+2}}$, where n is a positive integer.
- 2** Use the given information about an arithmetic sequence to find the common difference d and the general term A_n .
- a** $A_1 = 3$ and $A_5 = 23$ **b** $A_6 = -8$ and $A_{11} = 53$
c $A_4 = 8$ and $A_8 = 10$
- 3** Use the given information about a geometric sequence to find the indicated values.
- a** $G_1 = 10$ and $r = 2$, find G_4 . **b** $G_1 = 4$ and $r = -3$, find G_6 .
c $G_3 = 1$ and $G_6 = 216$, find G_1 and r .
d $G_2 = \frac{1}{\sqrt{3}}$, $G_5 = -\frac{1}{9}$, find r , G_8 and the general term G_n .

- 4** For any pair of non-negative integers a and b , show that the arithmetic mean between a and b is greater than or equal to the geometric mean between them.
- 5** Find the first term of the sequence 4, 12, 36, 108, . . . which exceeds 20,000.
- 6** Find the first term of the sequence 10, 5, 2.5, 1.25, . . . which is less than 0.0001.
- 7** Insert four arithmetic and five geometric means between 2 and 20.
- 8** If $x, 4, y$ are in geometric progression and $x, 5, y$ are in arithmetic progression, determine the value(s) of x and y .
- 9** If $\{g_n\}$ is a geometric sequence with $g_n > 0$ for all $n \in \mathbb{N}$, then prove that $\{\ln g_n\}$ is an arithmetic sequence.

1.3**THE SIGMA NOTATION AND PARTIAL SUMS****OPENING PROBLEM**

As we know, each of us has parents, grandparents, great grandparents, great - great grandparents and so on. What is the total number of such relatives you have from your parents to your tenth grandparents?

In the previous section, you were interested in the individual terms of a sequence. In this section, you describe the process of adding the terms of a sequence. i.e., given a sequence $\{a_n\}$, you are interested in finding the sum of the first n terms called the **partial sum**, denoted by S_n . Thus if $a_1, a_2, a_3, \dots, a_n, \dots$ are the terms of the sequence, then you put;

$$S_1 = a_1, \quad S_1 \text{ is the first term of the sequence.}$$

$$S_2 = a_1 + a_2, \quad S_2 \text{ is the sum of the first two terms of the sequence.}$$

$$S_3 = a_1 + a_2 + a_3, \quad S_3 \text{ is the sum of the first three terms of the sequence.}$$

$$S_4 = a_1 + a_2 + a_3 + a_4, \quad S_4 \text{ is the sum of the first four terms of the sequence.}$$

and so on.

$$S_n = a_1 + a_2 + a_3 + a_4 + \dots + a_n, \quad S_n \text{ is the sum of the first } n \text{ terms of the sequence.}$$

Example 1 Find the sum of the first

a 5 natural numbers.

$$\text{Hence, } S_5 = 1 + 2 + 3 + 4 + 5 = 15.$$

b 10 natural numbers that are multiples of 3.

$$\text{Hence, } S_{10} = 3 + 6 + 9 + 12 + 15 + 18 + 21 + 24 + 27 + 30 = 165.$$

Example 2 Given the general term, $a_n = 3n - 5$, find

- a** the sum of the first 6 terms. **b** the sum of the first 10 terms.

Solution

a The first 6 terms of the sequence $a_n = 3n - 5$ are $-2, 1, 4, 7, 10$ and 13 .

Hence, $S_6 = -2 + 1 + 4 + 7 + 10 + 13 = 33$.

b The first 10 terms of the sequence $a_n = 3n - 5$ are

$-2, 1, 4, 7, 10, 13, 16, 19, 21$ and 24 .

Hence, $S_{10} = -2 + 1 + 4 + 7 + 10 + 13 + 16 + 19 + 21 + 24 = 113$

Example 3 Given the general term $a_n = \frac{1}{n} - \frac{1}{n+1}$, find the sum of the first,

- a** 99 terms **b** n -terms

Solution

a
$$S_{99} = \left(1 - \frac{1}{2}\right) + \left(\frac{1}{2} - \frac{1}{3}\right) + \left(\frac{1}{3} - \frac{1}{4}\right) + \dots + \left(\frac{1}{99} - \frac{1}{100}\right) = 1 - \frac{1}{100} = 0.99$$

b
$$S_n = 1 - \frac{1}{2} + \frac{1}{2} - \frac{1}{3} + \frac{1}{3} - \dots + \frac{1}{n-1} - \frac{1}{n} + \frac{1}{n} - \frac{1}{n+1} = 1 - \frac{1}{n+1} = \frac{n}{n+1}$$

So that $S_1 = \frac{1}{2}, S_2 = \frac{2}{3}, S_{10} = \frac{10}{11}, S_{99} = \frac{99}{100}, \dots$ etc.

Note:

✓ Such a sequence is said to be telescoping sequence.

When you have a formula for the general term of a sequence, you can express the sum of the first n -terms of the sequence in a more compact form using a special notation for sums. The Greek (upper case) letter sigma, \sum often called the **summation symbol**, is used along with the general term of the sequence.

NOTATION:

$$\sum_{i=1}^n a_i = a_1 + a_2 + a_3 + \dots + a_n$$

In this notation, i is called **index of the summation** or simply the **index**. 1 is the **lower limit** and n is the **upper limit**.

Definition 1.4

Let $\{a_n\}_{n=1}^{\infty}$ be a sequence, the sum of the first n terms of the sequence, denoted by S_n , is called the **partial sum** of the sequence.

NOTATION

$$S_n = \sum_{i=1}^n a_i = a_1 + a_2 + a_3 + \dots + a_n$$

Since sigma notation is merely a shorthand way of denoting a sum, we can restate some of the real number properties using sigma notation.

Properties of \sum

$$1 \quad \sum_{k=1}^n ca_k = c \sum_{k=1}^n a_k, \text{ where } c \text{ is a constant.} \quad 2 \quad \sum_{k=1}^n (a_k + b_k) = \sum_{k=1}^n a_k + \sum_{k=1}^n b_k$$

$$3 \quad \sum_{k=1}^n (a_k - b_k) = \sum_{k=1}^n a_k - \sum_{k=1}^n b_k$$

$$4 \quad \sum_{k=1}^n a_k = \sum_{k=1}^m a_k + \sum_{k=m+1}^n a_k, \text{ where } 1 \leq m < n.$$

Example 4 Evaluate each of the following.

$$a \quad \sum_{i=1}^{10} 3i \quad b \quad \sum_{j=3}^{10} (5j - 4) \quad c \quad 4 \sum_{k=1}^6 k^2 + 4 \sum_{k=7}^{10} k^2$$

Solution

$$a \quad \sum_{i=1}^{10} 3i = 3(1) + 3(2) + 3(3) + 3(4) + 3(5) + 3(6) + 3(7) + 3(8) + 3(9) + 3(10) \\ = 3 + 6 + 9 + 12 + 15 + 18 + 21 + 24 + 27 + 30 = 165$$

$$\text{Whereas } 3 \sum_{i=1}^{10} i = 3(1 + 2 + 3 + \dots + 10) = 3 \times 55 = 165$$

$$b \quad \sum_{j=3}^{10} (5j - 4) = 5(3) - 4 + 5(4) - 4 + 5(5) - 4 + 5(6) - 4 + 5(7) - 4 + 5(8) - 4 + 5(9) - 4 + 5(10) - 4 \\ = 11 + 16 + 21 + 26 + 31 + 36 + 41 + 46 = 228$$

$$\text{Whereas } 5 \sum_{j=3}^{10} j - \sum_{j=3}^{10} 4 = 5(3 + 4 + 5 + \dots + 10) - \underbrace{(4 + 4 + \dots + 4)}_{8\text{-times}} = 5 \times 52 - 4 \times 8 = 228$$

$$c \quad \sum_{k=1}^{10} 4k^2 = 4(1^2) + 4(2^2) + 4(3^2) + \dots + 4(10^2) \\ = 4(1 + 4 + 9 + \dots + 100) = 4(385) = 1540$$

$$\text{Whereas } 4 \sum_{k=1}^6 k^2 + 4 \sum_{k=7}^{10} k^2 = 4(91) + 4(294) = 1540$$

Example 5 Given a sequence for which $a_n = 2n^3$, evaluate

$$a \quad S_4 \quad b \quad S_6$$

Solution

$$a \quad S_4 = \sum_{k=1}^4 2k^3 = 2 \sum_{k=1}^4 k^3 = 2(1^3 + 2^3 + 3^3 + 4^3) = 200$$

$$\begin{aligned} \mathbf{b} \quad S_6 &= \sum_{k=1}^6 2k^3 = 2 \sum_{k=1}^6 k^3 = 2 \sum_{k=1}^4 k^3 + 2 \sum_{k=5}^6 k^3 = 2(1^3 + 2^3 + 3^3 + 4^3) + 2(5^3 + 6^3) \\ &= 200 + 682 = 882. \end{aligned}$$

Exercise 1.5

1 Use the given sequence or general term to find the indicated sum S_n .

- | | |
|--|---|
| a 3, 7, 11, 15, ...; S_6 | b -8, -3, 2, 7, ...; S_5 |
| c -2, 0, 2, 4, 6, ...; S_6 | d 1, 2, 4, 8, 16, ...; S_6, S_{10}, S_{20} |
| e $1, \frac{1}{2}, \frac{1}{4}, \frac{1}{8}, \dots$; $S_6, S_{10}, S_{20}, S_{100}$. Can you guess what S_n is? | |
| f $a_n = 3n + 1$, where n is a positive integer; $S_6, S_{10}, S_{20}, S_{100}$. | |
| g $a_n = 2n - 1$, where n is a positive integer; $S_6, S_{10}, S_{20}, S_{100}$. | |
| h $a_n = \log\left(\frac{n}{n+1}\right)$, where n is a positive integer; $S_6, S_{10}, S_{20}, S_{100}$. | |
| i $a_n = \frac{n}{n+1} - \frac{n+1}{n+2}$, where n is a positive integer; $S_6, S_{10}, S_{20}, S_{100}$. | |

Can you give a formula for S_n ?

2 Rewrite each sum without using sigma notation; then calculate each sum.

- | | | | |
|---|--|------------------------------------|------------------------------|
| a $\sum_{n=1}^5 n$ | b $\sum_{k=1}^4 4(k+2)$ | c $\sum_{k=1}^6 5(k-1)$ | d $\sum_{k=1}^8 3k$ |
| e $\sum_{k=2}^6 k^2$ | f $\sum_{k=3}^5 k^3$ | g $\sum_{k=1}^5 4$ | h $\sum_{k=3}^{10} 7$ |
| i $\sum_{m=1}^{10} \left(\frac{2}{m} - \frac{2}{m+1}\right)$ | j $\sum_{n=1}^8 \log_3\left(\frac{n+1}{n}\right)$ | k $\sum_{k=1}^6 \log_8 2^k$ | |

3 Use the sigma notation to represent the sum of the first n terms of the given sequences.

- | | |
|--|---|
| a 4, 8, 12, ..., $4k$, ... for $n = 5$. | b 2, 5, 8, ..., $3k-1$, ... for $n = 8$. |
| c 2, 8, 18, ..., $2k^2$, ... for $n = 7$. | d 7, 9, 11, ..., $(2k+5)$, ... for $n = 10$. |

4 Express the given sums using sigma notation.

- | | |
|--|---|
| a $2 + 6 + 10 + 14 + 18$ | b $5 + 25 + 125 + 625$ |
| c $1 + 3 + 5 + 7 + \dots + 51$ | d $4 + 7 + 10 + 13 + \dots + 52$ |
| e $\frac{1}{2} + \frac{1}{2 \times 3} + \frac{1}{3 \times 4} + \dots + \frac{1}{99 \times 100}$ | f $\frac{2}{5} + \frac{4}{9} + \frac{6}{13} + \dots + \frac{20}{41}$ |

1.3.1 Sum of Arithmetic Progressions

The particular structure of an arithmetic progression allowed you to develop a formula for its general term A_n . This same structure allows you to develop formulae for S_n , the sum of the first n terms of an arithmetic progression.

You begin by examining a special arithmetic sequence, $1, 2, 3, 4, \dots, n, \dots$ and its associated sum S_n .

$$S_n = 1 + 2 + 3 + \dots + n, \text{ the sum of the first } n \text{ terms (} n \text{ natural numbers).}$$

For $n = 100$, that is,

$$S_{100} = 1 + 2 + 3 + \dots + 98 + 99 + 100$$

Write the sum in reverse order

$$S_{100} = 100 + 99 + 98 + \dots + 3 + 2 + 1$$

Adding the two sums together, we get

$$2S_{100} = 101 + 101 + 101 + \dots + 101 + 101 + 101$$

$$\text{i.e., } 2S_{100} = 100 \times 101.$$

Therefore, $S_{100} = \frac{1}{2}100(101) = 5050$.



HISTORICAL NOTE

Carl Friedrich Gauss (1777-1855)

A teacher of Gauss, at his elementary school, asked him to *add all the integers from 1 to 100*. When Gauss returned with the correct answer after only a few moments, the teacher could only look at him in astounded silence. This is what Gauss did:

$$\begin{array}{r} 1 + 2 + 3 + \dots + 100 \\ 100 + 99 + 98 + \dots + 1 \\ \hline 101 + 101 + 101 + \dots + 101 \\ \hline \frac{100 \times 101}{2} = 5050 \end{array}$$



You can generalize this approach and derive a formula for the sum S_n , of the first n natural numbers. You follow the same steps as you just did for S_{100} .

$$S_n = 1 + 2 + 3 + \dots + (n-2) + (n-1) + n$$

Write the sum in reverse order:

$$S_n = n + (n-1) + (n-2) + \dots + 3 + 2 + 1$$

Add the two sums together:

$$2S_n = (n+1) + (n+1) + \dots + (n+1) + (n+1)$$

Therefore, you have $2S_n = n(n+1)$ and so, $S_n = \frac{n}{2}(n+1)$.

Thus, you have derived the following formula.

The sum of the first n positive integers is given by,

$$S_n = 1 + 2 + 3 + \dots + n = \frac{n}{2}(n+1).$$

Example 6 Find the sum of the first

- a** 30 natural numbers. **b** 150 natural numbers.

Solution

a Using formula, $S_n = \frac{n}{2}(n+1)$, $S_{30} = \frac{30}{2}(30+1) = 15(31) = 465$

b Using formula, $S_n = \frac{n}{2}(n+1)$ $S_{150} = \frac{150}{2}(150+1) = 75(151) = 11,325.$

You can now derive the general formula for the sum S_n of the first n terms of an arithmetic progression.

That is, $S_n = A_1 + A_2 + A_3 + \dots + A_n$, where $\{A_n\}_{n=1}^{\infty}$ is an arithmetic sequence.

But then, $A_n = A_1 + (n-1)d$, where d is the common difference and so,

$$S_n = A_1 + (A_1 + d) + (A_1 + 2d) + (A_1 + 3d) + \dots + (A_1 + (n-1)d)$$

By collecting all the A_1 terms (there are n of them) we get,

$$S_n = nA_1 + [d + 2d + 3d + \dots + (n-1)d]$$

Now factoring out d from within the brackets,

$$S_n = nA_1 + d[1 + 2 + 3 + \dots + (n-1)]$$

Inside the brackets, you have the sum of the first $(n-1)$ positive integers. Thus by

using the formula, $S_n = \frac{n}{2}(n+1)$, you get

$$S_n = nA_1 + d\left(\frac{n-1}{2}\right)n = \frac{2nA_1 + n(n-1)d}{2} = \frac{n[2A_1 + (n-1)d]}{2}$$

Hence, you have proved the following theorem.

Theorem 1.3

The sum S_n of the first n terms of an arithmetic sequence with first term A_1 and common difference d is:

$$S_n = \sum_{k=1}^n A_k = \frac{n}{2}[2A_1 + (n-1)d].$$

This formula can also be written as

$$S_n = \frac{n}{2}(A_1 + (A_1 + (n-1)d)) = \frac{n}{2}(A_1 + A_n) = n\left(\frac{A_1 + A_n}{2}\right),$$

where A_n is the n^{th} term. This alternative formula is useful when the first and the last terms are known.

Example 7 Given the arithmetic sequence: 3, 7, 11, 15, ..., find

a S_{20} **b** S_{80}

Solution

a Since the given sequence is an arithmetic sequence with $A_1 = 3$ and common difference $d = 4$, you can substitute these values in the formula

$$S_n = \sum_{k=1}^n A_k = \frac{n}{2}[2A_1 + (n-1)d]$$

Thus, $S_{20} = \sum_{k=1}^{20} A_k = \frac{20}{2}(2(3) + (20-1)4) = 10(6 + 19(4)) = 10(82) = 820.$

b $S_n = \sum_{k=1}^n A_k = \frac{n}{2}[2A_1 + (n-1)d]$

$$S_{80} = \sum_{k=1}^{80} A_k = \frac{80}{2}(2(3) + (80-1)4) = 40(6 + 79(4)) = 12,880.$$

Example 8 Find the sum of the first 35 terms of the sequence whose general term is $A_n = 5n$.

Solution From the general term, we get $A_1 = 5$ and $A_{35} = 5(35) = 175$.

Since we can easily identify the first and the 35th term, we use the formula,

$$S_n = \frac{n}{2}(A_1 + A_n) = n\left(\frac{A_1 + A_n}{2}\right)$$

Thus substituting, $A_1 = 5$, and $A_{35} = 175$, we get

$$S_{35} = \frac{35}{2}(5 + 175) = 35\left(\frac{5 + 175}{2}\right) = 35(90) = 3,150.$$

Try to find the sum of this sequence using the other formula

$$S_n = \sum_{k=1}^n A_k = \frac{n}{2}[2A_1 + (n-1)d]. \text{ Which formula is easier to use in this example?}$$

Example 9 If the n^{th} partial sum of an arithmetic sequence $\{a_n\}$ is $3n^2$, find a_n .

Solution Notice that $a_n = S_n - S_{n-1}$. (*Explain*)

$$\Rightarrow a_n = 3n^2 - 3(n-1)^2 = 6n - 3.$$

Example 10 A water reservoir is being filled with water at the rate of $4000 \text{ m}^3/\text{hr}$ for the first hour, $5000 \text{ m}^3/\text{hr}$ for the second hour, $6,000 \text{ m}^3/\text{hr}$ for the third hour and it increases by $1000 \text{ m}^3/\text{hr}$ at the end of every hour. It is completely filled in 8 hours. Find the capacity of the reservoir.

Solution Observe the sequence of the volumes of water being filled at the end of every hour $4,000 \text{ m}^3$, $5,000 \text{ m}^3$, $6,000 \text{ m}^3$, ..., form an arithmetic sequence with $A_1 = 4,000$ and $d = 1,000$.

The volume of water being filled in 8 hours is

$$S_8 = \frac{8}{2} (2 \times 4,000 + 7 \times 1,000) \text{ m}^3 = 60,000 \text{ m}^3.$$

Thus, the capacity of the reservoir is $60,000 \text{ m}^3$.

1.3.2 Sum of Geometric Progressions

The particular structure of a geometric progression allowed you to develop a formula for its general term G_n . This same structure allows you to develop formulae for S_n , the sum of the first n terms of a geometric progression, as you did for arithmetic progressions.

If $\{G_n\}_{n=1}^{\infty}$ is a geometric sequence, then its associated geometric sum, S_n is

$$S_n = G_1 + G_2 + G_3 + \dots + G_{n-1} + G_n$$

As with the case of the sum of arithmetic sequence, we can find a formula to describe a geometric sum which is associated with a geometric sequence.

Let $\{G_n\}_{n=1}^{\infty}$ be a geometric sequence with common ratio r , then $G_n = r^{n-1}G_1$ for each n .

Thus, $S_n = G_1 + G_2 + G_3 + \dots + G_{n-1} + G_n$ implies that

$$S_n = G_1 + rG_1 + r^2G_1 + \dots + r^{n-2}G_1 + r^{n-1}G_1$$

Factoring out G_1 , you get

$$S_n = G_1(1 + r + r^2 + \dots + r^{n-2} + r^{n-1})$$

$$rS_n = G_1(r + r^2 + r^3 + \dots + r^{n-1} + r^n) \quad \text{Multiplying both sides by } r$$

$$S_n - rS_n = G_1(1 + r + r^2 + \dots + r^{n-2} + r^{n-1}) - G_1(r + r^2 + r^3 + \dots + r^{n-1} + r^n) \quad \text{Subtracting } rS_n \text{ from } S_n$$

$$(1 - r)S_n = G_1(1 - r^n), \text{ and so } S_n = \frac{G_1(1 - r^n)}{1 - r} \text{ for } r \neq 1$$

Thus, you have proved the following theorem:

Theorem 1.4

Let $\{G_n\}_{n=1}^{\infty}$ be a geometric sequence with common ratio r . Then the sum of the first n terms S_n is given by,

$$S_n = \begin{cases} nG_1, & \text{if } r=1. \\ G_1 \frac{(1-r^n)}{1-r} = G_1 \frac{(r^n-1)}{r-1}, & \text{if } r \neq 1. \end{cases}$$

Example 11 Given the geometric sequence: 1, 3, 9, 27, ..., find

a S_5 **b** S_{10}

Solution

a From the given sequence $G_1 = 1$ and $r = 3$, thus using the formula

$$S_n = \frac{G_1(1-r^n)}{1-r}, \text{ you get } S_5 = \frac{1(1-3^5)}{1-3} = \frac{-242}{-2} = 121.$$

b By using the same formula as in **a**, $S_n = \frac{G_1(1-r^n)}{1-r}$, we get

$$S_{10} = \frac{1(1-3^{10})}{1-3} = \frac{-59048}{-2} = 29,524$$

Exercise 1.6

- 1** Find the sum S_8 of the arithmetic sequence whose first term is 4 and the common difference is 5.
- 2** Find the sum S_{10} of the arithmetic sequence whose first term is 8 and the common difference is -1 .
- 3** Find the sum S_7 of the arithmetic sequence whose fourth term is 2 and whose seventh term is 17.
- 4** Find the sums S_8 , S_{12} , S_{20} and S_{100} of the geometric sequence whose first term is 4 with common ratio 5.
(What happens to the sum S_n as n becomes “larger and larger”?)
- 5** Find the sum S_8 , S_{12} , S_{20} and S_{100} of the geometric sequence whose first term is 4 with common ratio $\frac{2}{3}$.
(What happens to the sum S_n as n becomes “larger and larger”?)
- 6** Given the sum $S_{10} = 165$ of an arithmetic sequence and $A_1 = 3$, find A_{10} .
- 7** Given the sum $S_{20} = 910$ of an arithmetic sequence and $A_{20} = 95$, find A_1 .

- 8** Given the sum $S_{16} = 368$ of an arithmetic sequence and $A_1 = 1$, find A_8 .
- 9** Given the sum $S_n = 969$ of an arithmetic sequence, $A_1 = 9$ and common difference $d = 6$ find n .
- 10** Find the sum of all 3-digit whole numbers that are divisible by 13.
- 11** Find the sum of n -arithmetic means which are inserted between any two real numbers a and b .
- 12** In an arithmetic sequence, the fourth term is 84 and the tenth term is 60. Find the maximum possible partial sum.
- 13** If A_1 and A_2 are arithmetic means between any two real numbers a and b and G_1 and G_2 are geometric means between a and b , express $\frac{A_1 + A_2}{G_1 G_2}$ in terms of a and b .
- 14** Evaluate each of the following sums.
- a** $\sum_{n=1}^{20} (5n + 7)$ **b** $\sum_{n=1}^6 (-1)^{n+1} \frac{n}{n+1}$ **c** $\sum_{n=2}^5 \frac{3^n}{5^{n+1}}$
- d** $\sum_{k=0}^7 \frac{2^k}{k!}$ **e** $\sum_{j=2}^{10} \frac{(-1)^{j-3}}{j}$ **f** $\sum_{k=1}^{20} k^2$
- 15** A woman started a business by Birr 3000.00. She lost Birr 100 in the first month, Birr 60 in the second month, Birr 20 in the third month and so on. Assuming that this improvement continued at the same rate, determine her total capital in 2 years and 7 months.
- 16** The population of a certain city increases at the rate of 3% per year. If the present population of the city is 400000, find the population after
- a** 4 years **b** 10 years
- 17** A person invested in two different organizations A and B. He invested Birr 10,000 in A that increases Birr 300 per year and Birr 16,000 in B that increases by 5% per year.
- a** Determine the amount in each organization after 10 years.
- b** Find a formula for the amount of money in each organization after n years.
- c** Determine the number of years that the amount in A exceeds the amount in B.
- 18** Suppose you pay 20% tax when you buy a certain machine. If you buy the machine for Birr 20,000 and sale it for Birr 12,000, the buyer will pay 20% tax and sale it for Birr 7,200. If this process continues without end, find the total tax that can be collected.

1.4 INFINITE SERIES



OPENING PROBLEM

A ball is dropped freely from a height of 16 m. Each time it drops h metre, it rebounds $0.81 h$ metre.

- a** What is the total vertical distance travelled by the ball before it comes to rest?
- b** The ball takes the following times for each fall.

$$\begin{aligned}
 S_1 &= -16t^2 + 16, & S_1 &= 0 \text{ if } t = 1; \\
 S_2 &= -16t^2 + 16(0.81), & S_2 &= 0 \text{ if } t = 0.9; \\
 S_3 &= -16t^2 + 16(0.81)^2, & S_3 &= 0 \text{ if } t = (0.9)^2; \\
 S_4 &= -16t^2 + 16(0.81)^3, & S_4 &= 0 \text{ if } t = (0.9)^3; \\
 &\vdots & &\vdots \\
 &\vdots & &\vdots \\
 &\vdots & &\vdots \\
 S_n &= -16t^2 + 16(0.81)^{n-1}, & S_n &= 0 \text{ if } t = (0.9)^{n-1};
 \end{aligned}$$

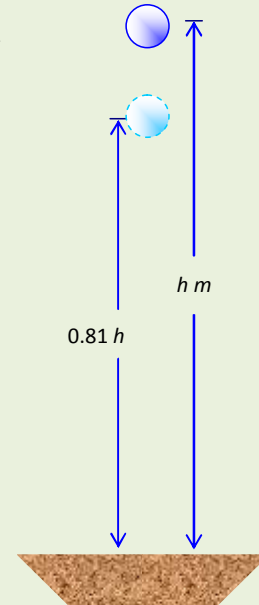

Figure 1.4

Beginning with S_2 , the ball takes the same amount of time to bounce up as it does to fall. What is the total time before it comes to rest?

If you try to add the terms of an infinite sequence $\{a_n\}_{n=1}^{\infty}$, you get an expression of the form:

$$a_1 + a_2 + a_3 + \dots + a_n + \dots$$

We call such a sum an **infinite series** and denote it by the sigma notation as

$$a_1 + a_2 + a_3 + \dots + a_n + \dots = \sum_{n=1}^{\infty} a_n$$

But does it make sense to talk about the sum of infinitely many terms?

We may get the answer after the following activities.

ACTIVITY 1.7

1 Is it possible to find the sum of the following?

a $1 + 2 + 3 + 4 + 5 + \dots + n + \dots$

b $1 + 3 + 5 + 7 + \dots + (2n - 1) + \dots$



c	$\frac{1}{2} + \frac{1}{4} + \frac{1}{8} + \frac{1}{16} + \dots + \frac{1}{2^n} + \dots$	d	$-1 + 1 + -1 + 1 + -1 + \dots + (-1)^n + \dots$
e	$\frac{1}{3} + \frac{1}{9} + \frac{1}{27} + \frac{1}{81} + \dots + \frac{1}{3^n} + \dots$	f	$2 + 4 + 8 + 16 + \dots + 2^n + \dots$

2 Find the n^{th} partial sum S_n for each of the above **a – f**.

3 What happens to the partial sum S_n as n gets “larger and larger”?

Let us examine **a**, **c** and **d**.

a $S_n = \frac{n}{2}(n+1)$ the sum of the first n natural numbers.

As n becomes “larger and larger”, S_n gets “larger and larger”.

That is as n increases indefinitely, S_n also increases indefinitely. Or as n tends to infinity, S_n tends to infinity. Symbolically, as $n \rightarrow \infty$, $S_n \rightarrow \infty$

c $S_n = \frac{G_1(1-r^n)}{1-r}$; partial sum of a geometric series with $G_1 = \frac{1}{2}$ and $r = \frac{1}{2}$

$$\text{Therefore } S_n = \frac{\frac{1}{2}\left(1 - \left(\frac{1}{2}\right)^n\right)}{1 - \frac{1}{2}} = 1 - \left(\frac{1}{2}\right)^n$$

As $n \rightarrow \infty$, the value of $\left(\frac{1}{2}\right)^n$ becomes almost zero. Hence, $S_n \rightarrow 1$.

d $S_n = -1 + 1 + -1 + 1 + -1 + \dots + (-1)^n = \begin{cases} 0 & \text{if } n \text{ is even} \\ -1 & \text{if } n \text{ is odd} \end{cases}$

As $n \rightarrow \infty$, $S_n \rightarrow 0$ or -1 , depending on whether n is even or odd.

Thus, as $n \rightarrow \infty$, S_n **does not approach a unique number**. In such cases, the infinite sum doesn't exist.

In the case of **c** in which as $n \rightarrow \infty$, $S_n \rightarrow 1$; we define the infinite sum to be 1.

$$\text{That is, } \sum_{n=1}^{\infty} \left(\frac{1}{2}\right)^n = \frac{1}{2} + \frac{1}{4} + \frac{1}{8} + \dots + \left(\frac{1}{2}\right)^n + \dots = 1$$

However, in the cases **a** and **d** the sum does not exist; the sum is not unique in **d**; and the sum is not a finite number in **a**.

Now in general, as n tends to infinity, if the partial sum tends to a unique finite number s , then we say the infinite series **converges** and the infinite sum is equal to s ; otherwise, the infinite series is said to be **divergent**.

Definition 1.5

Let $\{a_n\}_{n=1}^{\infty}$ be a sequence and S_n be the n^{th} partial sum such that, as $n \rightarrow \infty$, $S_n \rightarrow s$ where s is a finite real number, then we say the infinite series $\sum_{n=1}^{\infty} a_n$ **converges** and is written as $\sum_{n=1}^{\infty} a_n = s$.

However, if such an s does not exist or is infinite, we say the infinite series $\sum_{n=1}^{\infty} a_n$ **diverges**.

Example 1 Determine whether the series $\sum_{n=1}^{\infty} (3)^n$ converges or diverges.

Solution The series $\sum_{n=1}^{\infty} (3)^n = 3 + 9 + 27 + \dots + 3^n + \dots$ is a geometric series with $G_1 = 3$ and common ratio $r = 3$. Hence, the partial sum is given by

$$S_n = \frac{G_1(1-r^n)}{1-r}$$

Substituting the values, we obtain,

$$S_n = \frac{3[1-(3)^n]}{1-3} = -\frac{3}{2}[1-(3)^n] = \frac{-3}{2} + \frac{3}{2}(3)^n$$

Thus, as $n \rightarrow \infty$, $S_n \rightarrow \infty$

Therefore, the series diverges.

Recall that, if $\{G_n\}_{n=1}^{\infty}$ is a geometric series with common ratio r , then

$$S_n = G_1 \frac{(1-r^n)}{1-r} = \frac{G_1}{1-r} - \frac{G_1 r^n}{1-r}$$

If $|r| < 1$, as $n \rightarrow \infty$, $r^n \rightarrow 0$ so that

$$S_n = \frac{G_1}{1-r} - \frac{G_1 r^n}{1-r} \rightarrow \frac{G_1}{1-r} \Rightarrow S_{\infty} = \frac{G_1}{1-r}$$

Example 2 Evaluate

a $\frac{1}{2} + \frac{1}{4} + \frac{1}{8} + \dots$

b $1 - \frac{3}{5} + \frac{9}{25} - \frac{27}{125} + \dots$

Solution

a This is an infinite geometric series with $G_1 = \frac{1}{2}$ and $r = \frac{1}{2}$.

$$\text{Hence, } S_\infty = \frac{G_1}{1-r} = \frac{\frac{1}{2}}{1-\frac{1}{2}} = 1.$$

b Here, $G_1 = 1$, $r = -\frac{3}{5}$. Hence, $S_\infty = \frac{1}{1-\left(-\frac{3}{5}\right)} = \frac{5}{8}$.

Example 3 Write $0.\dot{6}$ as a rational number.

Solution $0.\dot{6} = 0.6 + 0.06 + 0.006 + \dots = \frac{6}{10} + \frac{6}{100} + \frac{6}{1000} + \dots$

which is an infinite geometric series with $r = \frac{1}{10}$ and $G_1 = \frac{6}{10}$.

$$\text{Thus, } S_\infty = \frac{G_1}{1-r} = \frac{\frac{6}{10}}{1-\frac{1}{10}} = \frac{\frac{6}{10}}{\frac{9}{10}} = \frac{2}{3}.$$

Example 4 A ball is dropped from a height of 30m above a flat surface. In each bounce, it rebounds to 0.3 of the distance it fell. Find the maximum possible vertical distance the ball could travel.

Solution Each time, the ball travels 0.3 times the distance it fell, as shown in **Figure 1.5**. Assuming that the ball never comes to rest, the total distance is

$$S = 30 + 2\left(\frac{9}{1-0.3}\right)m = 55.7m. \quad (\text{Explain!}).$$

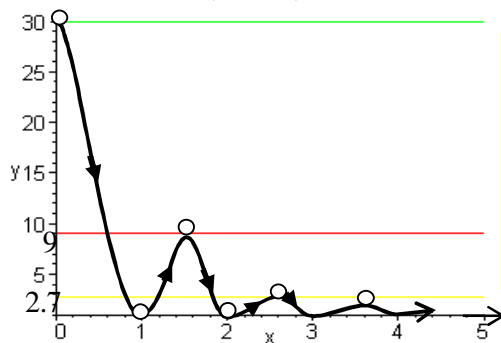

Note that the ball is bouncing vertically and we assume no horizontal movement. The horizontal axis of this graph is only to indicate the bounces of the ball.

Figure 1.5

Example 5 In **Figure 1.6**, an infinite number of rectangles are constructed under the graph of $f(x) = 2^{-x}$. Find the sum of the areas of all the rectangles.

Solution The n^{th} rectangle has unit length and height 2^{-n} units. Hence, the area of the n^{th} rectangle is $A_n = 2^{-n}$ square unit.

$$\begin{aligned}\Rightarrow \sum_{n=1}^{\infty} A_n &= \frac{2^{-1}}{1-2^{-1}} = \frac{0.5}{1-0.5} \text{ square units} \\ &= 1 \text{ unit square.}\end{aligned}$$

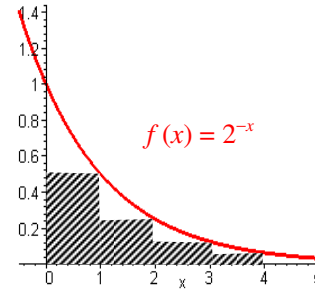

Figure 1.6

Exercise 1.7

1 Find each of the following sums if it exists, assuming the patterns continue as in the first few terms.

a $2 + 1 + \frac{1}{2} + \frac{1}{4} + \dots$

b $1 + \frac{2}{3} + \frac{4}{9} + \frac{8}{27} + \dots$

c $\frac{1}{5} + \frac{1}{10} + \frac{1}{20} + \dots$

d $\frac{1}{5} + \frac{-1}{10} + \frac{1}{20} + \frac{-1}{40} + \dots$

e $\frac{1}{5} + \frac{4}{15} + \frac{16}{45} + \dots$

f $7 + \frac{7}{10} + \frac{7}{100} + \frac{7}{1000} + \dots$

g $\sum_{k=1}^{\infty} 4^{3-k}$

h $\sum_{k=1}^{\infty} 4^{k-3}$

i $\sum_{k=1}^{\infty} 5 \left(\frac{1}{3} \right)^{k-1}$

j $\sum_{n=1}^{\infty} (-1)^{n+1} \left(\frac{2}{3} \right)^n$

k $\sum_{k=2}^{\infty} \left(\frac{3}{4} \right)^{k+3} \left(\frac{2}{3} \right)^{k-2}$

2 Express each of the following as a fraction using the infinite sum.

a $0.\bar{4}$

b $0.3\bar{7}$

c $3.235\bar{4}$

d $13.4529\bar{81}$

3 Find the product $5 \cdot 5^{\frac{1}{2}} \cdot 5^{\frac{1}{4}} \cdot \dots \cdot 5^{\frac{1}{2^n}} \dots$

4 If $\sum_{k=1}^{\infty} 5^{kr} = \frac{1}{4}$, find the value of r .

5 If the product $3^r \cdot 3^{r^2} \cdot 3^{r^3} \dots = 3$, find r .

6 Suppose a ball is dropped from a height of h m and always rebounds to r of the height from which it falls. Show that the total vertical distance that could be covered by the ball is $h \left(\frac{r+1}{1-r} \right)$ m. Assume that the ball will never stop bouncing.

1.5

APPLICATIONS OF ARITHMETIC PROGRESSIONS AND GEOMETRIC PROGRESSIONS

This section is devoted to the applications of arithmetic and geometric progressions or geometric series (binomial series) that are associated with real life situations. Here are some examples followed by exercises. The examples shown here and the following exercises illustrate some useful applications.

Example 1 A job applicant finds that a firm offers a starting annual salary of Birr 32,500 with a guaranteed raise of Birr 1,400 per year.

- a** What would the annual salary be in the tenth year?
- b** Over the first 10 years, how much would be earned at the firm?

Solution

- a** The annual salary at the firm forms the arithmetic sequence; 32,500, 33,900, 35,300, ... with first term $A_1 = 32,500$ and common difference $d = 1,400$.

Thus, $A_n = A_1 + (n-1)d$, substituting the values we obtain;

$$A_{10} = 32,500 + (10-1)1,400 = \text{Birr } 45,100$$

- b** To determine the amount that would be earned over the first 10 years, we need to add the first 10 annual salaries;

$$S_{10} = A_1 + A_2 + A_3 + \dots + A_{10} = 10 \left(\frac{A_1 + A_{10}}{2} \right)$$

(It is 10 times the average of the first and the last term.)

$$S_{10} = \frac{10}{2}(32,500 + 45,100) = \text{Birr } 388,000.$$

Therefore, over the first 10 years a total of Birr 388,000 would be earned at the firm.

Example 2 A woman deposits Birr 3,500 in a bank account paying an annual interest at a rate of 6%. Show that the amounts she has in the account at the end of each year form a geometric sequence.

Solution Let $G_1 = 3,500$. Then,

$$G_2 = G_1 + \frac{6}{100}G_1 = G_1(1 + 0.06) = 3,500(1.06) = 3,710.$$

$$G_3 = G_2 + \frac{6}{100}G_2 = G_2(1 + 0.06) = G_1(1.06)(1.06) = 3,710(1.06) = 3,932.6.$$

Continuing in this way you get $G_n = (1.06)^{n-1}G_1$

Since the ratio of any two consecutive terms is a constant, which is 1.06, this sequence is a geometric sequence.

Example 3 Suppose a substance loses half of its radioactive mass per year. If we start with 100 grams of a radioactive substance, how much is left after 10 years?

Solution Let us record the amount of the radioactive substance left after each year starting with $G_0 = 100$. Note that each term is half of the previous term and hence,

$$G_1 = \frac{1}{2}(100) = 50\text{g is the amount left at the end of year 1.}$$

$$G_2 = \frac{1}{2}(50) = 25\text{g is the amount left at the end of year 2.}$$

If you continue in this way, you see that the ratio of any two consecutive terms is a constant, which is $\frac{1}{2}$, and hence this sequence is a geometric sequence.

Therefore, after ten years, the amount of the substance left is given by

$$G_{10} = \left(\frac{1}{2}\right)^{10} G_0 = \left(\frac{1}{2}\right)^{10} (100) = \frac{100}{1,024} = 0.09765625\text{g.}$$

Binomial series

You remember that the **binomial theorem** states

$$(a + bx)^n = a^n + na^{n-1}(bx) + \frac{n(n-1)}{2!}a^{n-2}(bx)^2 + \frac{n(n-1)(n-2)}{3!}a^{n-3}(bx)^3 + \dots + (bx)^n$$

for any positive integer n .

In particular for $a = 1$ and $b = 1$, you have

$$(1 + x)^n = 1 + nx + \frac{n(n-1)}{2!}x^2 + \frac{n(n-1)(n-2)}{3!}x^3 + \dots + x^n$$

Now, if you consider the infinite series $1 - x + x^2 - x^3 + \dots$, then it is a geometric series with common ratio $-x$. Moreover, for $|x| < 1$, it converges to $\frac{1}{1+x} = (1+x)^{-1}$

In general, for any value of n ,

$$(1+x)^n = 1 + nx + \frac{n(n-1)}{2!}x^2 + \frac{n(n-1)(n-2)}{3!}x^3 + \dots (*)$$

and this type of series is called a **binomial series**. This series converges for $|x| < 1$. The binomial series generalizes the binomial theorem to any real values of n . If n is a positive integer the binomial series reduces to binomial theorem.

Example 4 Expand each of the following expressions.

a $(1+x)^{\frac{1}{2}}$ **b** $(1-3x)^{-5}$ **c** $(3x+2)^{-4}$

Solution

a Replacing n by $\frac{1}{2}$ in (*) gives you,

$$\begin{aligned} (1+x)^{\frac{1}{2}} &= 1 + \frac{1}{2}x + \frac{\frac{1}{2}\left(\frac{1}{2}-1\right)x^2}{2!} + \frac{\frac{1}{2}\left(\frac{1}{2}-1\right)\left(\frac{1}{2}-2\right)x^3}{3!} + \dots \\ &= 1 + \frac{1}{2}x - \frac{1}{8}x^2 + \frac{1}{16}x^3 - \frac{5}{128}x^4 + \dots \quad \text{provided that } |x| < 1. \end{aligned}$$

b Replacing n by -5 and x by $(-3x)$ in (*) gives you.

$$\begin{aligned} (1-3x)^{-5} &= 1 + (-5)(-3x) + \frac{(-5)(-5-1)(-3x)^2}{2!} + \frac{-5(-5-1)(-5-2)(-3x)^3}{3!} + \dots \\ &= 1 + 15x + 135x^2 + 945x^3 + 5670x^4 + \dots \quad \text{provided that } |x| < \frac{1}{3}. \end{aligned}$$

c Observe that $(2x+3)^{-4} = \left(3\left(\frac{2}{3}x+1\right)\right)^{-4} = 3^{-4}\left(\frac{2}{3}x+1\right)^{-4}$

Hence,

$$\begin{aligned} (2x+3)^{-4} &= 3^{-4} \left(1 + (-4)\left(\frac{2}{3}x\right) + \frac{(-4)(-4-1)\left(\frac{2}{3}x\right)^2}{2!} + \frac{(-4)(-4-1)(-4-2)\left(\frac{2}{3}x\right)^3}{3!} + \dots \right) \\ &= \frac{1}{81} - \frac{8}{243}x + \frac{40}{729}x^2 - \frac{160}{2187}x^3 + \frac{560}{6561}x^4 - \dots \end{aligned}$$

The binomial series is useful for approximations. When you have an expression of the form $(1 + x)^n$ where $|x| < 1$, you can take $(1 + x)^n$ to be equal to only the first few terms of the series.

Example 5 Find the approximate value of $\sqrt[3]{6}$ correct to four decimal places.

Solution: You know that 6 is not a perfect cube but using the perfect cube 8, rewrite $\sqrt[3]{6}$ as

$$\sqrt[3]{6} = \sqrt[3]{8-2} = \sqrt[3]{8\left(1-\frac{2}{8}\right)} = \sqrt[3]{8} \sqrt[3]{1-\frac{1}{4}} = 2\left(1-\frac{1}{4}\right)^{\frac{1}{3}}.$$

Hence replacing n by $\frac{1}{3}$ and x by $-\frac{1}{4}$ in (*), you have

$$\begin{aligned} \sqrt[3]{6} &= 2\left(1-\frac{1}{4}\right)^{\frac{1}{3}} = 2\left(1 + \frac{1}{3}\left(-\frac{1}{4}\right) + \frac{\left(\frac{1}{3}\right)\left(\frac{1}{3}-1\right)\left(-\frac{1}{4}\right)^2}{2!} + \frac{\frac{1}{3}\left(\frac{1}{3}-1\right)\left(\frac{1}{3}-2\right)\left(-\frac{1}{4}\right)^3}{3!} + \dots\right) \\ &= 2\left(1 - \frac{1}{12} - \frac{1}{144} - \frac{5}{5184} - \dots\right) \\ &= 1.817515430988 \\ &\Rightarrow \sqrt[3]{6} = 1.8175 \text{ correct to four decimal places.} \end{aligned}$$

Exercise 1.8 (Application Problems)

- 1** A person is scheduled to get a raise of Birr 250 every 6 months during his/her first 5 years on the job. If his/her starting salary is Birr 25,250 per year, what will his/her annual salary be at the end of the 3rd year?
- 2** Rosa begins a saving program in which she will save Birr 1,000 the first year, and each subsequent year she will save 200 more than she did the previous year. How much will she save during the eighth year?
- 3** A certain item loses one-tenth of its value each year. If the item is worth Birr 28,000 today, how much will it be worth 4 years from now?
- 4** A boat is now worth Birr 34,000 and loses 12% of its value each year. What will it be worth after 5 years?
- 5** The population of a certain town is increasing at a rate of 2.5% per year. If the population is currently 100,000, what will the population be 10 years from now?

- 6** Sofia deposits Birr 3,500 in a bank account paying an annual interest rate of 6%. Find the amount she has at the end of
- a** the first year **b** the second year **c** the third year
d the fourth year **e** the n^{th} year
f Do the amounts she has at the end of each year form a geometric sequence? Explain.
- 7** A job applicant finds that a firm A offers a starting salary of Birr 31,100 with a guaranteed raise of Birr 1,200 per year, whereas firm B offers a higher starting salary of Birr 35,100 but will guarantee a yearly raise of only Birr 900.
- a** What would the annual salary be in the 11th year at firm A?
b What would the annual salary be in the 11th year at firm B?
c Over the first 11 years, how much would be earned at firm A?
d Over the first 11 years, how much would be earned at firm B?
e Compare the amount earned in 11 years in firms A and B.
- 8** A theatre hall has 38 rows of seats. The first row has 17 seats, the second row has 20 seats, the third row has 23 seats and so on. What is the seating capacity of the theatre hall?
- 9** A contest offers a total of 18 prizes. The first prize is worth Birr 10,000, and each consecutive prize is worth Birr 500 less than the next higher prize. Find the value of the eighteenth prize and the total value of the prizes.
- 10** A contest offers 10 prizes with a total value of Birr 13,250. If the difference in value between consecutive prizes is Birr 250, what is the value of the first prize?
- 11** A ball bounces up one-half the distance from which it falls. How far does it bounce up on the fifth rebound, if the ball is dropped from a height of 20 metres?
- 12** A ball is dropped from a height of 60 metres and always rebounds one-third the distance from which it falls. Find the total distance the ball has travelled when it hits the ground for the fifth time and the tenth time.
- 13** In **Problem 12** above, if you let the ball bounce “forever”, what is the total distance it would travel until it comes to rest?
- 14** Expand each of the following using binomial series.
- a** $(x - 4)^{-7}$ **b** $(1 + x)^{\frac{3}{2}}$ **c** $\frac{1}{\sqrt{4 - x}}$
- 15** Approximate each of the following using binomial series.
- a** $\sqrt{5}$ **b** $\sqrt[3]{9}$ **c** $\sqrt[4]{17}$



Key Terms

arithmetic mean	finite sequence	recursion formula
arithmetic sequence	general term	sequence
common difference	geometric mean	series
common ratio	geometric sequence	sigma notation
convergent series	infinite sequence	telescoping sequence
divergent series	infinite series	terms of a sequence
Fibonacci sequence	partial sums	



Summary

1 Sequence

- ✓ A sequence $\{a_n\}$ is a function whose domain is the set of positive integers or a subset of consecutive integers starting with 1.
- ✓ The sequence $\{a_1, a_2, a_3, \dots\}$ is denoted by $\{a_n\}$ or $\{a_n\}_{n=1}^{\infty}$.
- ✓ A sequence that has a last term is called a **finite sequence**. Otherwise it is called **infinite sequence**.
- ✓ **Recursion formula** is a formula that relates the general term a_n of a sequence to one or more of the terms that come before it.

2 Arithmetic and geometric progression

i Arithmetic progression

- ✓ An arithmetic sequence is one in which the difference between consecutive terms is a constant, and this constant is called the **common difference**.
- ✓ If $\{A_n\}$ is an arithmetic progression with the first term A_1 and the common difference d , then the n^{th} term is given by:

$$A_n = A_1 + (n - 1)d.$$

ii Geometric progression

- ✓ A geometric progression is one in which the ratio between consecutive terms is a constant, and this constant is called the **common ratio**.
- ✓ If $\{G_n\}$ is a geometric progression with the first term G_1 and a common ratio r , then the n^{th} term is given by:

$$G_n = r^{n-1} G_1.$$

3 Partial sums

✓ The sum of the first n terms of the sequence $\{a_n\}_{n=1}^{\infty}$, denoted by S_n is called the **partial sum of the sequence**.

✓ The sum S_n of the first n terms of an arithmetic sequence with first term A_1 , and common difference d is:

$$S_n = \sum_{k=1}^n A_k = \frac{n}{2}[2A_1 + (n-1)d].$$

✓ In a geometric sequence, $\{G_n\}_{n=1}^{\infty}$ with common ratio r , the sum of the first n terms S_n is given by;

$$S_n = \begin{cases} nG_1, & \text{if } r = 1 \\ \frac{G_1(r^n - 1)}{r - 1}, & \text{if } r \neq 1 \end{cases}$$

4 Convergent series and divergent series

✓ In a sequence $\{a_n\}_{n=1}^{\infty}$, if S_n is the n^{th} partial sum such that, as $n \rightarrow \infty$, $S_n \rightarrow s$ where s is a finite real number, we say the infinite series $\sum_{n=1}^{\infty} a_n$ converges to s , otherwise the series diverges.

Review Exercises on Unit 1

1 Find the first five terms of the sequence with the specified general term.

a $a_n = \frac{1}{2n+1}$ **b** $a_n = (n-1)^2$ **c** $a_n = (-1)^n n!$

d $a_n = \frac{3n-1}{3n+1}$ **e** $a_n = \frac{1}{n} \sin\left(\frac{n}{6}\pi\right)$ **f** $a_n = \frac{n^2-3}{n^2+3}$

2 Find the first five terms of the recursively defined sequence.

a $a_1 = -2$ and $a_n = \frac{1}{a_{n-1}}$ for $n \geq 2$

b $a_1 = 1$, $a_2 = 3$ and $a_n = \frac{a_{n-1}}{a_{n-2}}$ for $n \geq 3$

c $a_1 = 1$, $a_n = (a_{n-1})^n$ for $n \geq 2$

d $a_1 = 0$, $a_2 = 1$, $a_n = a_{n-1} + a_{n-2}$ for $n \geq 3$

- 3** Find the general term of an arithmetic sequence that satisfies the given conditions.
- The first two terms are 4 and 7.
 - The fourth term is 11 and the tenth term is 35.
 - The tenth term is 3 and the fifteenth term is 5.5.
 - The third term is $2\sqrt{2}$ and the sixth term is $4\sqrt{2}$.
- 4** Find the general term of a geometric sequence that satisfies the given conditions.
- The first two terms are -1 and $\frac{1}{4}$.
 - The third term is $\frac{2}{9}$ and the fifth term is $\frac{2}{243}$.
 - The second term is $\frac{\sqrt{2}}{2}$ and the fourth term is $\sqrt{2}$.
 - The first term is 0.15 and the third term is 0.0015.
- 5** Evaluate each of the following sums.
- | | | | | | |
|----------|--|----------|--|----------|--|
| a | $\sum_{k=1}^{10} 3k - 1$ | b | $\sum_{n=1}^{12} (4 - 5n)$ | c | $\sum_{k=0}^5 \frac{2^k}{2k + 1}$ |
| d | $\sum_{k=0}^{10} (3 + (-1)^k)$ | e | $\sum_{k=2}^{12} (-1)^k 2^k$ | f | $\sum_{k=1}^5 \frac{2^{k+5}}{3^{k-1}}$ |
| g | $\sum_{k=1}^{\infty} \left(\frac{3^k + 2^k}{6^k} \right)^2$ | h | $\sum_{k=0}^{\infty} \left(\frac{2}{3} \right)^{k-4}$ | i | $\sum_{k=1}^{20} 2 \left(\frac{3}{2} \right)^k$ |
| j | $\sum_{k=1}^{\infty} \left(-\frac{1}{3} \right)^{k+5}$ | k | $\sum_{k=0}^{10} \frac{5^k}{4^k}$ | l | $\sum_{k=1}^5 (-3(5^k))$ |
- 6** Find the sum of whole numbers that are less than 100 and leave remainder 2 when divided by 5.
- 7** Evaluate each of the following infinite series.
- $2 - \sqrt{2} + 1 - \frac{1}{\sqrt{2}} - \frac{1}{2} + \dots$
 - $9 + 3\sqrt{3} + 3 + \sqrt{3} + 1 + \frac{1}{\sqrt{3}} + \dots$
 - $\frac{-3}{4} + \frac{9}{4} - \frac{27}{4} + \dots$
 - $1 + x + x^2 + x^3 + \dots$ (in terms of x)
 - $0.1 + 0.11 + 0.111 + 0.1111 + \dots$
- 8** Find the sum of all two-digit whole numbers which are divisible by 11.

- 9** In an arithmetic sequence, the sum of the first 20 terms is 950 and the sum of the second 20 terms is 0. Find the general term of the sequence.
- 10** When n arithmetic means are inserted between 8 and 44, the sum of the resulting terms is 338. Find the values of n and the common difference.
- 11** A car that is bought for Birr 125000.00 depreciates in value by Birr 4000 per year. How long will it take for the car to make a loss of 25% of its value? (to the nearest year).
- 12** A person invests Birr 1,000,000.00 for the first year. During each succeeding years he invests Birr 300,000.00 more than he did the year before. How much will he invest over a period of 20 years?
- 13** A factory that produces cement had sales Birr 100,000.00 the first day and sales increased by Birr 8,000.00 every day during each successive days. Find the total sales of the factory during the first 30 days.
- 14** If the construction of a certain school is not completed by the agreed upon date, the contractor pays a penalty of Birr 1,000 for the first week, Birr 2,000 for the second week, Birr 3,000 for the third week and so on that it is overdue. If construction of the school is completed 13 weeks late, calculate the total amount of the penalties that the contractor must pay.
- 15** Suppose you earn Birr 10,000.00 per month and pay 20% tax and spend 60% of it. Again the recipient of the money spent by you pays 20% tax and spends 60% of it. If this process continues without end, find the total amount that will be paid for the tax.
- 16** Expand each of the following expressions using binomial series and determine the values of x for which it converges.

a $(9 + x)^{\frac{1}{2}}$

b $(1 + 5x)^{-\frac{5}{2}}$

c $(2 - x)^{\frac{3}{2}}$

Unit

2

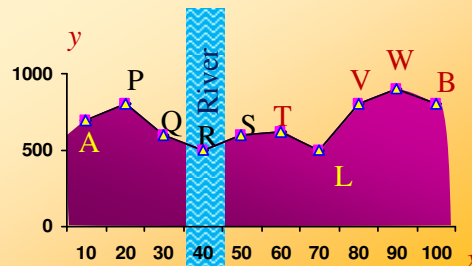

INTRODUCTION TO LIMITS AND CONTINUITY

Unit Outcomes:

After completing this unit, you should be able to:

- *understand the concept of "limit" intuitively.*
- *find out limits of sequences of numbers.*
- *determine the limit of a given function.*
- *determine continuity of a function over a given interval.*
- *apply the concept of limits to solve real life mathematical problems.*
- *develop a suitable ground for dealing with differential and integral calculus.*

Main Contents

- 2.1 LIMITS OF SEQUENCES OF NUMBERS**
- 2.2 LIMITS OF FUNCTIONS**
- 2.3 CONTINUITY OF A FUNCTION**
- 2.4 EXERCISES ON APPLICATIONS OF LIMITS**

Key terms

Summary

Review Exercises

INTRODUCTION

This unit deals with the fundamental objects of calculus: limits and continuity.

Limits are theoretical in nature but we start with interpretations.

Limit can be used to describe how a function behaves as the independent variable approaches a certain value.

For example, consider the function $f(x) = \frac{x^2 - 1}{x - 1}$. Then $f(1) = \frac{0}{0}$ has no meaning. The form $\frac{0}{0}$ is said to be indeterminate form because it is not possible to assign a unique value to it.

This function is not defined at $x = 1$. However, it still makes sense to ask what happens to the values of $f(x)$ as the value of x becomes closer to 1 without actually being equal to 1. You can verify using a calculator that $f(x) = \frac{x^2 - 1}{x - 1}$ approaches to 2 whenever you take any value very close to 1 for x .

This means that $f(x)$ has a well-defined value near $x = 1$ on either side of 1.

Limits are used in several areas of mathematics, including the study of rates of change, approximations and calculations of area.

For example, you know how to approximate the population of your kebele in 2012, but what is different in limits is you will learn how to know the rate of change of population in your kebele in 2012.



OPENING PROBLEM

Imagine that a regular polygon with n -sides is inscribed in a circle.

- 1** As n gets large, what happens to the length of each side of the polygon?
- 2** What will be the limiting shape of the polygon as n goes to infinity?
- 3** Will the polygon ever get to the circle?

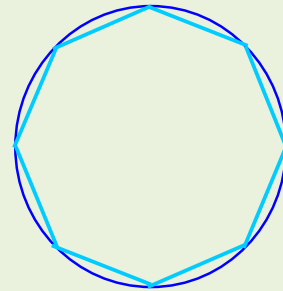

Figure 2.1

2.1 LIMITS OF SEQUENCES OF NUMBERS

ACTIVITY 2.1



- 1 Find the maximum and minimum elements of each of the following sets.
- a** $\{1, 2, 3, \dots, 10\}$ **b** $\{1, -1, 1, -1, \dots\}$ **c** $\{x \in \mathbb{R} : -3 \leq x < 5\}$
- d** $\left\{\frac{1}{n} : n \in \mathbb{N}\right\}$ **e** $\{x \in \mathbb{R} : -1 \leq x \leq 2\}$ **f** $\{x \in \mathbb{R} : -5 < x \leq 4\}$
- g** $\{x \in \mathbb{R} : |x| < 5\}$
- 2 For each of the following sequences $\{a_n\}$, find m and k such that
- i** $a_n \leq m$, for all n **ii** $a_n \geq k$, for all n
- a** $a_n = 2^n + 1$ **b** $a_n = \frac{1}{3^n}$ **c** $a_n = (-1)^n \left(1 + \frac{1}{n}\right)$
- d** $a_n = \frac{n+1}{n}$ **e** $a_n = 7 + \frac{1}{n}$ **f** $a_n = \frac{10^n - 1}{10^n}$

2.1.1 Upper Bounds and Lower Bounds

The numbers m and k in **Activity 2.1** are said to be an **upper bound** and a **lower bound** of the sequences, respectively.

Definition 2.1

Let $\{a_n\}$ be a sequence and $m, M \in \mathbb{R}$. Then

- i** M is said to be an **upper bound** of $\{a_n\}$, if $M \geq a_i$ for all $a_i \in \{a_n\}$.
- ii** m is said to be a **lower bound** of $\{a_n\}$, if $m \leq a_i$ for all $a_i \in \{a_n\}$
- iii** A sequence is said to be **bounded**, if it has an upper bound (is bounded above) and if it has a lower bound (is bounded below).

Note:

- ✓ A sequence $\{a_n\}$ is bounded, if and only if there exists $k > 0$ such that $|a_n| \leq k$ for all $n \in \mathbb{N}$.

Example 1 Consider the sequence $\left\{\frac{1}{n}\right\}$, where the terms are: $1, \frac{1}{2}, \frac{1}{3}, \frac{1}{4}, \dots$

Clearly, $0 < \frac{1}{n} \leq 1$ for all $n \in \mathbb{N}$.

Some upper bounds are: 1, 2, $\sqrt{3}$, 5, and some lower bounds are: 0, -2, -3, -5, -7.

Thus, $\left\{\frac{1}{n}\right\}$ is a bounded sequence.

Example 2 Show that the following sequences are bounded.

a $\{(-1)^n\}$ **b** $\left\{\frac{4n-1}{2n}\right\}$

Solution

a The sequence $\{(-1)^n\}$ is bounded because $-1 \leq (-1)^n \leq 1$ for all $n \in \mathbb{N}$.

b Consider the graph of the rational function $y = \frac{4x-1}{2x}$. The horizontal asymptote, $y = 2$, is the limiting line of the curve.

If we mark the points $\left(n, \frac{4n-1}{2n}\right)$ on the curve of the rational function, it gives the graph of the sequence. The terms are increasing from $\frac{3}{2}$ to 2.

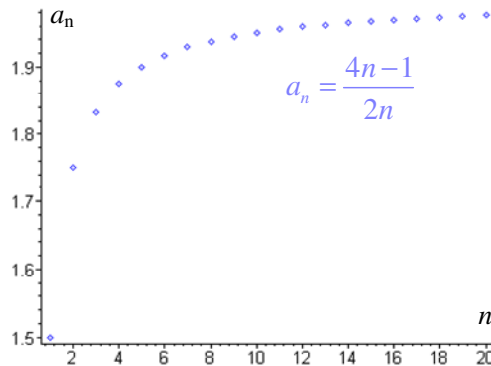

Figure 2.2

Thus, $\frac{3}{2} \leq \frac{4n-1}{2n} < 2$ for all $n \in \mathbb{N}$. This shows that $\left\{\frac{4n-1}{2n}\right\}$ is bounded.

Example 3 For each of the following sequences,

- i** find some upper bounds and some lower bounds.
- ii** determine the greatest element of the set of lower bounds and the least element of the set of upper bounds.

a $\left\{\frac{(-1)^n}{n}\right\}$ **b** $\{1-n\}$ **c** $\{2^n\}$ **d** $\left\{\left(\frac{1}{n}\right)^n\right\}$

Solution One of the strategies in finding upper bounds and lower bounds of a sequence is to list the first few terms and observe any trend.

a The first few terms of $\left\{\frac{(-1)^n}{n}\right\}$ are:

$$-1, \frac{1}{2}, -\frac{1}{3}, \frac{1}{4}, -\frac{1}{5}, \dots,$$

which are consisting of negative and positive values with -1 the minimum term and $\frac{1}{2}$ the maximum term.

$$\text{Hence, } -1 \leq \frac{(-1)^n}{n} \leq \frac{1}{2} \text{ for all } n \in \mathbb{N}.$$

The set of lower bounds is the interval $(-\infty, -1]$ whose greatest element is -1 .

The set of upper bounds is the interval $\left[\frac{1}{2}, \infty\right)$ whose least element is $\frac{1}{2}$.

b The terms of $\{1 - n\}$ are:

$$0, -1, -2, -3, \dots,$$

which are decreasing to negative infinity starting from 0. This shows that the sequence has no lower bound (is unbounded below). The set of upper bounds is $[0, \infty)$ with 0 the least element of all the upper bounds.

c When we consider $\{2^n\}$, the terms are 2, 4, 8, 16, \dots , which are starting from 2 and indefinitely increasing. Thus, $\{2^n\}$ has no upper bound, whereas the interval $(-\infty, 2]$ is the set of the lower bounds with 2 being the greatest element.

d The terms of $\left\{\left(\frac{1}{n}\right)^n\right\}$ are non-negative numbers starting from 1 and

decreasing to 0 at a faster rate as compared to $\left\{\frac{1}{n}\right\}$.

$$\text{Look at its terms: } 1, \frac{1}{4}, \frac{1}{27}, \frac{1}{256}, \dots$$

$$\text{Clearly, } 0 < \left(\frac{1}{n}\right)^n \leq 1, \text{ for all } n \in \mathbb{N}$$

Thus the set of lower bounds is $(-\infty, 0]$ with 0 being the greatest element and the set of upper bounds is $[1, \infty)$ with 1 the least element.

The following table contains a few upper bounds and a few lower bounds.

Sequence	Few upper bounds	Few lower bounds
$\left\{ \frac{(-1)^n}{n} \right\}$	$\frac{1}{2}, 1, 4, 10$	$-1, -2, -5, -7.5$
$\{1 - n\}$	$0, 1, \pi, 5$	None
$\{2^n\}$	None	$2, \frac{1}{2}, 0, -\sqrt{10}$
$\left\{ \left(\frac{1}{n} \right)^n \right\}$	$1, 2, 3, 12$	$0, -1, -2, -\pi$

Least upper bound (lub) and greatest lower bound (glb)

In **Example 3** above, you have seen the least element of the set of upper bounds and the greatest element of the set of lower bounds. Now, you consider sequences of numbers in general and give the following formal definition.

Definition 2.2

Let $\{a_n\}$ be a sequence of numbers.

- 1** x is said to be the **least upper bound (lub)** of $\{a_n\}$
 - i** if x is an upper bound of $\{a_n\}$, and
 - ii** whenever y is an upper bound of $\{a_n\}$, then $x \leq y$.
- 2** x is called the **greatest lower bound (glb)** of $\{a_n\}$
 - i** if x is a lower bound of $\{a_n\}$ and
 - ii** whenever y is a lower bound of $\{a_n\}$, then $x \geq y$.

You may determine the lub or glb of a sequence using different techniques of describing a sequences such as listing the first few terms or plotting points.

In the following example, to determine the lub and glb plotting the points might be much more helpful than listing the terms.

Example 4 Find the lub and glb of the sequence $\left\{ \frac{2n-3}{n+1} \right\}$

Solution If the general term of a sequence has a rational expression, then plotting the points on the curve of the corresponding rational function can be helpful.

Consider the graph of $y = \frac{2x-3}{x+1}$.

If you have values for the natural numbers, then it gives the graph of the sequence.

The sequence increases from $-\frac{1}{2}$ to 2.

Its elements are limited by the horizontal asymptote of the rational function.

Hence, $-\frac{1}{2} \leq \frac{2n-3}{n+1} \leq 2$ for all $n \in \mathbb{N}$.

Therefore, the glb is $-\frac{1}{2}$ and the lub

is 2.

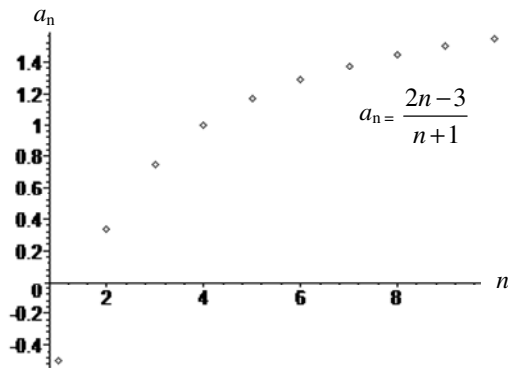

Figure 2.3

Example 5 Find the lub and glb of each of the following sequences.

- a** $\left\{\frac{1}{n}\right\}$ **b** $\{(-1)^n\}$ **c** $\left\{\frac{(-1)^n + 1}{2}\right\}$
d $\left\{1 - \frac{1}{n}\right\}$ **e** $\left\{1 - \frac{(-1)^n}{n}\right\}$ **f** $\left\{\frac{2}{3^n}\right\}$

Solution In this example, listing the first few terms is sufficient to determine the lub and glb.

Look at the following table.

Sequence	First few terms	lub	glb
$\left\{\frac{1}{n}\right\}$	$1, \frac{1}{2}, \frac{1}{3}, \frac{1}{4}, \frac{1}{5}, \dots$ Decreases to 0	1	0
$\{(-1)^n\}$	$-1, 1, -1, 1, \dots$ Oscillates	1	-1
$\left\{\frac{(-1)^n + 1}{2}\right\}$	$0, 1, 0, 1, \dots$ Oscillates	1	0
$\left\{1 - \frac{1}{n}\right\}$	$0, \frac{1}{2}, \frac{2}{3}, \frac{3}{4}, \frac{4}{5}, \dots$ Increases to 1	1	0
$\left\{1 - \frac{(-1)^n}{n}\right\}$	$2, \frac{1}{2}, \frac{4}{3}, \frac{3}{4}, \frac{6}{5}, \frac{5}{6}, \dots$ (odd terms a_{2n-1} decrease to 1, even terms a_{2n} increase to 1) Converges to 1	2	$\frac{1}{2}$
$\left\{\frac{2}{3^n}\right\}$	$\frac{2}{3}, \frac{2}{9}, \frac{2}{27}, \frac{2}{81}, \dots$ Decreases to 0	$\frac{2}{3}$	0

Example 6 Find the glb and lub for each of the following sequences.

a $\left\{2^{\frac{1}{n}}\right\}$ **b** $\left\{(0.01)^{\frac{1}{n}}\right\}$

Solution These sequences need a calculator or a computer to list as many terms as Possible; alternatively plot the corresponding function graph.

a The lub is 2 and the glb is 1 **b** The lub is 1 and the glb is 0.01.

Exercise 2.1

For each of the following sequences, find some upper bounds and lower bounds and determine the lub and glb.

1 $\left\{\frac{(-1)^n}{n+3}\right\}$ **2** $\left\{\frac{n-1}{n+1}\right\}$ **3** $\left\{\frac{3n-2}{n}\right\}$ **4** $\left\{(-1)^n\left(1-\frac{1}{n}\right)\right\}$
5 $\left\{\frac{1-3n}{2n+5}\right\}$ **6** $\left\{2^{\frac{1}{n}}(-1)^n\right\}$ **7** $\left\{\frac{n+2}{3n-7}\right\}$ **8** $\left\{n^{\frac{1}{n}}\right\}$
9 $\left\{\frac{n!}{n^n}\right\}$ **10** $\left\{\frac{2^n}{n!}\right\}$

Monotonic sequences

Definition 2.3

Let $\{a_n\}$ be a sequence of numbers. Then,

- i** $\{a_n\}$ is said to be an increasing sequence, if $a_n \leq a_{n+1}$, for all $n \in \mathbb{N}$.
 i.e. $\{a_n\}$ is increasing, if and only if
 $a_1 \leq a_2 \leq a_3 \leq \dots \leq a_n \leq a_{n+1} \leq \dots$
- ii** $\{a_n\}$ is said to be strictly increasing if $a_n < a_{n+1}$, for all $n \in \mathbb{N}$
- iii** $\{a_n\}$ is said to be a decreasing sequence, if $a_n \geq a_{n+1}$, for all $n \in \mathbb{N}$. i.e., $\{a_n\}$ is decreasing, if and only if
 $a_1 \geq a_2 \geq a_3 \geq \dots \geq a_n \geq a_{n+1} \geq \dots$
- iv** $\{a_n\}$ is said to be strictly decreasing, if $a_n > a_{n+1}$, for all $n \in \mathbb{N}$

Example 7 Show that the sequence $\left\{3-\frac{1}{n}\right\}$ is strictly increasing.

Solution This can be seen directly from the order of the terms:

$$3 - 1 < 3 - \frac{1}{2} < 3 - \frac{1}{3} < 3 - \frac{1}{4}$$

$$\text{Also, } n < n + 1 \Rightarrow \frac{1}{n} > \frac{1}{n+1} \Rightarrow -\frac{1}{n} < -\frac{1}{n+1}$$

$$\Rightarrow 3 - \frac{1}{n} < 3 - \frac{1}{n+1}, \text{ for all } n \in \mathbb{N} \Rightarrow \left\{ 3 - \frac{1}{n} \right\} \text{ is strictly increasing.}$$

Example 8 Show that $\left\{ 3 + \frac{1}{n} \right\}$ is strictly decreasing.

Solution Note that $3 + 1 > 3 + \frac{1}{2} > 3 + \frac{1}{3} > \dots > 3 + \frac{1}{n} > 3 + \frac{1}{n+1} > \dots$

$$\Rightarrow 3 + \frac{1}{n} > 3 + \frac{1}{n+1}, \forall n \in \mathbb{N}$$

$$\Rightarrow \left\{ 3 + \frac{1}{n} \right\} \text{ is strictly decreasing.}$$

Definition 2.4

A sequence $\{a_n\}$ is said to be monotonic or a monotone sequence, if it is either increasing or decreasing.

Example 9 Show that $\left\{ \frac{(-1)^n}{n} \right\}$ is not monotonic.

Solution It suffices to list the first few terms of the sequence.

The terms $-1, \frac{1}{2}, -\frac{1}{3}, \frac{1}{4}, \dots$ are neither in an increasing order nor in a decreasing order. Thus, $\left\{ \frac{(-1)^n}{n} \right\}$ is not monotonic.

Example 10 Decide whether or not each of the following sequences is monotonic.

a $\left\{ 8 - \frac{1}{n} \right\}$ **b** $\left\{ 8 + \frac{1}{n} \right\}$ **c** $\left\{ 1 - \frac{(-1)^n}{n} \right\}$

Solution

a In $\left\{ 8 - \frac{1}{n} \right\}$, since $\left\{ -\frac{1}{n} \right\}$ is increasing to 0, $\left\{ 8 - \frac{1}{n} \right\}$ is increasing to 8.

Hence, it is monotonic.

b $\left\{\frac{1}{n}\right\}$ is a decreasing sequence; it is decreasing to 0. Hence $\left\{8+\frac{1}{n}\right\}$ decreases to 8.

Hence, it is monotonic.

c You can write the terms of the sequence as:

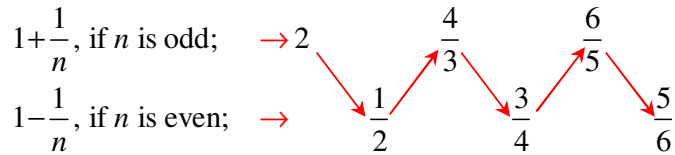

This shows that $\left\{1 - \frac{(-1)^n}{n}\right\}$ is not monotonic.

Exercise 2.2

1 Show that each of the following sequences is monotonic and bounded.

a $\left\{\frac{n+1}{2n-1}\right\}$	b $\left\{\frac{1}{n^2+4}\right\}$	c $\left\{3^n\right\}$
d $\sin\left(\frac{\pi}{2n}\right)$	e $\cos\left(\frac{1}{n}\right)$	f $\left\{\frac{2n+1}{n+5}\right\}$

2 Give examples of convergent sequences that are not monotonic.

3 Give examples of bounded sequences that are not convergent.

4 Can you find a convergent sequence that is not bounded?

5 In each of the following, determine whether or not the sequence is bounded.

a $\left\{n + \frac{1}{n}\right\}$	b $\left\{7 + \frac{2}{n}\right\}$	c $\left\{\frac{4}{n^2+1}\right\}$	d $\{\sin(n)\}$
e $\left\{7^{\frac{1}{n}}\right\}$	f $\left\{\left(\frac{1}{e}\right)^n\right\}$	g $\left\{\frac{\sqrt{n}-1}{\sqrt{n}+1}\right\}$	h $\left\{\ln\left(\frac{1}{n}\right)\right\}$

6 Use an appropriate method to show that each of the following sequences converges.

a $\left\{3 + \frac{4}{n}\right\}$	b $\left\{\frac{2n-3}{3n+2}\right\}$	c $\left\{\frac{1}{n+1} - \frac{2}{n+3}\right\}$
d $\left\{\frac{1+3+5+\dots+(2n-1)}{6n^2+1}\right\}$	e $\left\{\frac{2^{n+1}}{5^{n-4}}\right\}$	f $\left\{\frac{2n}{n^2+100}\right\}$
g $\left\{\sin\left(\frac{\pi}{n}\right)\right\}$	h $\left\{1 + \frac{(-1)^n}{n}\right\}$	

2.1.2 Limits of Sequences



OPENING PROBLEM

Consider the terms of the sequence $\left\{ \frac{1}{n} \right\}$

- 1 List terms of $\left\{ \frac{1}{n} \right\}$ that satisfy the condition $0 < \frac{1}{n} < 10^{-2}$
- 2 Find the smallest natural number k such that $0 < \frac{1}{n} < 10^{-5}$ for all $n \geq k$.

Sequences are common examples in the study of limits. In particular, sequences that tend to a unique value when n increases indefinitely are important in the introductory part of limits of sequences of numbers.

ACTIVITY 2.2

Decide whether each of the following sequences tends to a unique real number as n increases.



- | | | | | | | | |
|---|---|---|-------------------------------------|---|----------------|---|------------------|
| 1 | $\left\{ \frac{1}{n} \right\}$ | 2 | $\left\{ \frac{(-1)^n}{n} \right\}$ | 3 | $\{ 4 \}$ | 4 | $\{ -10^{-n} \}$ |
| 5 | $\left\{ \left(\frac{2}{3} \right)^n \right\}$ | 6 | $\left\{ \frac{n+5}{n} \right\}$ | 7 | $\{ (-1)^n \}$ | 8 | $\{ 2^n \}$ |

In **Activity 2.2**, the terms of some of the sequences are tending to a unique real number L as n gets larger and larger.

Consider the terms of the sequence $\left\{ \frac{1}{n} \right\}$:

$$1, \frac{1}{2}, \frac{1}{3}, \frac{1}{4}, \dots, \frac{1}{n}, \frac{1}{n+1}, \dots$$

It is clear that as the value of n becomes larger and larger, the n^{th} term $\left(\frac{1}{n} \right)$ of the sequence becomes smaller in value and hence it becomes closer and closer to 0. Moreover, for extremely large values of n , it will be very hard to distinguish the values of $\frac{1}{n}$ from 0.

In this case, 0 is said to be the limit of the sequence $\left\{ \frac{1}{n} \right\}$ and you express this idea shortly

by writing $\lim_{n \rightarrow \infty} \frac{1}{n} = 0$.

Read $\lim_{n \rightarrow \infty} \frac{1}{n} = 0$ as "the limit of $\frac{1}{n}$ as n approaches to infinity is 0."

Also, for the sequence $\left\{ \frac{1}{2^n} \right\}$, whose terms are:

$$\frac{1}{2}, \frac{1}{4}, \frac{1}{8}, \frac{1}{16}, \dots, \frac{1}{2^n}, \frac{1}{2^{n+1}}, \dots$$

you can see that $\lim_{n \rightarrow \infty} \left(\frac{1}{2^n} \right) = 0$.

Observe that the terms of the sequence $\left\{ \frac{1}{2^n} \right\}$ are decreasing to 0 at a rate faster than that of $\left\{ \frac{1}{n} \right\}$. **Figure 2.4** shows this comparison.

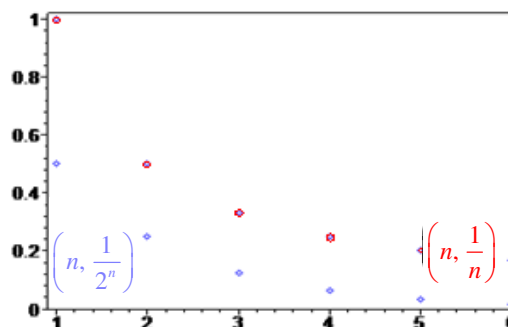

Figure 2.4

Note:

✓ If a constant c is added to the n^{th} term of the sequence $\left\{ \frac{1}{n} \right\}$, then you get the sequence $\left\{ c + \frac{1}{n} \right\}$ which converges to c .

Example 11 Consider the sequence $\left\{ 5 + \frac{1}{n} \right\}$, whose terms are

$$5 + 1, 5 + \frac{1}{2}, 5 + \frac{1}{3}, 5 + \frac{1}{4}, \dots, 5 + \frac{1}{n}, \dots$$

As n gets large, $\frac{1}{n}$ gets close to 0 so that $5 + \frac{1}{n}$ gets close to $5 + 0$.

$$\text{Therefore, } \lim_{n \rightarrow \infty} \left(5 + \frac{1}{n} \right) = 5.$$

This can be seen graphically, as follows; shifting the graph of $a_n = \frac{1}{n}$ by 5 units in the positive y -direction gives the graph of $a_n = 5 + \frac{1}{n}$, so that as n gets large its graph approaches the line with equation $y = 5$ instead of the line with equation $y = 0$.

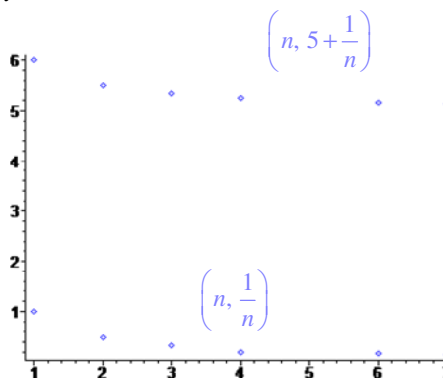

Figure 2.5

In general, for a sequence $\{a_n\}$, if there exists a unique real number L such that a_n becomes closer and closer to L as n becomes indefinitely large, then L is said to be the limit of $\{a_n\}$ as n approaches infinity.

Symbolically, this concept is written as: $\lim_{n \rightarrow \infty} a_n = L$

If such a real number L exists, then we say that $\{a_n\}$ converges to L . If such a number L does not exist, we say that $\{a_n\}$ diverges or $\lim_{n \rightarrow \infty} a_n$ does not exist.

Example 12 Show that the sequence $\{(-5)^n\}$ diverges.

Solution The terms of the sequence $\{(-5)^n\}$ are
 $-5, 25, -125, 625, \dots$

Thus, $\lim_{n \rightarrow \infty} (-5)^n$ does not approach a unique number. Therefore, $\{(-5)^n\}$ diverges.

Example 13 Show that the sequence $\{2^n\}$ diverges.

Solution The terms of the sequence $\{2^n\}$ are: $2, 2^2, 2^3, 2^4, \dots, 2^n, 2^{n+1}, \dots$ which are indefinitely increasing as n increases to infinity.

Thus, $\lim_{n \rightarrow \infty} (2^n) = \infty$. This shows that $\{2^n\}$ diverges.

Example 14 Decide whether or not the sequence $\frac{5n-2}{3n}$ converges.

Solution First we notice that $\frac{5n-2}{3n} = \frac{\left(\frac{5n-2}{n}\right)}{\left(\frac{3n}{n}\right)} = \frac{5 - \frac{2}{n}}{3}$

Together with $\lim_{n \rightarrow \infty} \frac{1}{n} = 0$, we have $\lim_{x \rightarrow \infty} \left(\frac{5 - \frac{2}{n}}{3}\right) = \frac{5}{3}$

Hence, the sequence $\left(\frac{5n-2}{3n}\right)$ converges to $\frac{5}{3}$.

Example 15 Show that the sequence $\{\sin(n)\}$ is divergent.

Solution You know that $-1 \leq \sin(n) \leq 1$. As n gets large, $\sin(n)$ still oscillates between -1 and 1 . It does not approach a unique number.

Thus, $\{\sin(n)\}$ diverges.

Null sequence

Definition 2.5

A sequence $\{a_n\}$ is said to be a null sequence, if and only if $\lim_{n \rightarrow \infty} a_n = 0$.

Example 16 Each of the following sequences is a null sequence.

a $\left\{\frac{1}{n}\right\}$ **b** $\left\{\frac{1}{10^n}\right\}$ **c** $\left\{\frac{1}{n^2+5}\right\}$ **d** $\left\{\frac{(-1)^n}{n}\right\}$

Example 17 Show that the sequence $\left\{\frac{\cos(n)}{n}\right\}$ is a null sequence.

Solution Notice that as n approaches to infinity, $-1 \leq \cos n \leq 1$.

So $\lim_{n \rightarrow \infty} \frac{\cos(n)}{n} = \frac{\text{finite quantity}}{\text{infinite quantity}} = 0$. Thus, $\left\{\frac{\cos(n)}{n}\right\}$ is a null sequence.

Example 18 Show that the sequence $\left\{\sin\left(\frac{1}{n}\right)\right\}$ is a null sequence.

Solution The terms of the sequence

$\sin(1), \sin\left(\frac{1}{2}\right), \sin\left(\frac{1}{3}\right), \dots$ are decreasing to $\sin 0$.

Thus, $\lim_{n \rightarrow \infty} \sin\left(\frac{1}{n}\right) = \sin(0) = 0$

This can be shown graphically:

As n goes to infinity, $\sin\frac{1}{n}$ tends to 0. Thus,

$\sin\left(\frac{1}{n}\right)$ is a null sequence.

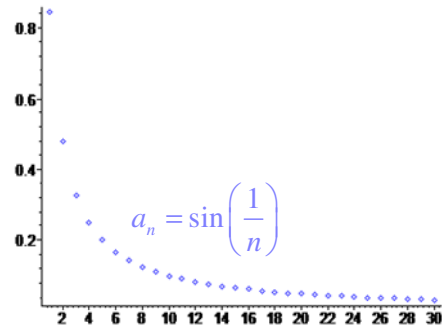

Figure 2.6

Exercise 2.3

1 Find the limit of each of the following sequences as n tends to infinity.

- | | | | |
|---|--|---|--|
| a $\left\{\frac{3}{n+1}\right\}$ | b $\left\{\frac{(-1)^n}{n^2}\right\}$ | c $\left\{\frac{1}{6^n}\right\}$ | d $\left\{7^{\frac{1}{n}}\right\}$ |
| e $\left\{(0.5)^{\frac{1}{n}}\right\}$ | f $\left\{1 - \frac{1}{n^2}\right\}$ | g $\left\{\frac{\cos(n)}{n}\right\}$ | h $\left\{\cos\left(\frac{1}{n}\right)\right\}$ |
| i $\left\{n + \frac{1}{n}\right\}$ | j $\left\{\frac{1+n}{2+n}\right\}$ | k $\left\{1, 0, \frac{1}{3}, 0, \frac{5}{7}, 0, \frac{7}{9}, 0, \dots\right\}$ | |
| l $\left\{\frac{n+3}{1-2n}\right\}$ | m $\left\{n - \frac{10}{n}\right\}$ | n $\left\{\frac{(-1)^n(n-1)}{n+1}\right\}$ | |
| o $\{0.6, 0.66, 0.666, \dots\}$ | | | |

2 Decide whether or not each of the following sequences is a null sequence.

a $\left\{ \frac{1}{n} \right\}$

b $\left\{ 1 - \frac{2}{n+1} \right\}$

c $\left\{ \frac{(-1)^n}{n^2+1} \right\}$

d $\left\{ \frac{3}{n(n+1)} \right\}$

e $\left\{ \left(\frac{7}{8} \right)^{n-2} \right\}$

f $\{ 2^n - 2^{-n} \}$

g $\left\{ \frac{4n-1}{n^2+1} \right\}$

h $\left\{ \frac{2^n}{n^2+1} \right\}$

i $\left\{ \frac{\sqrt{n+1}}{n} \right\}$

2.1.3 Convergence Properties of Sequences

ACTIVITY 2.3



1 Given on the next page are graphs of some sequences. Identify those graphs which are bounded and find their limits.

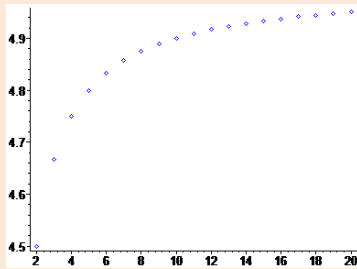

a

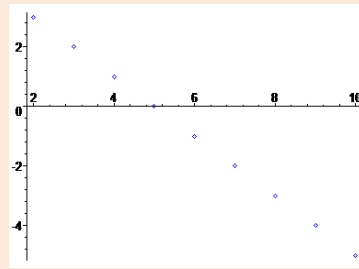

b

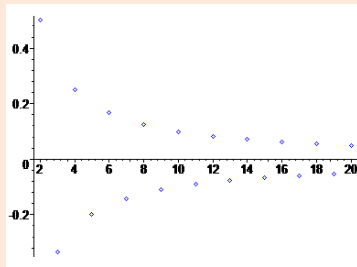

c

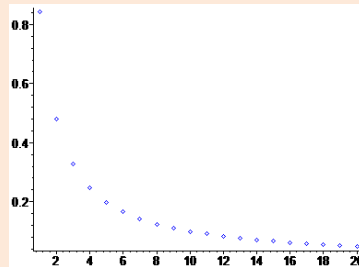

d

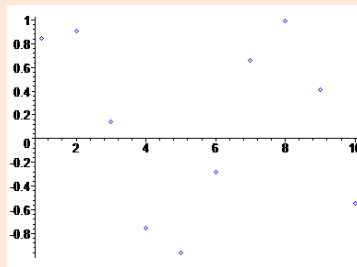

e

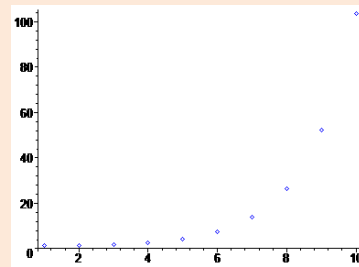

f

Figure 2.7

2 For each of the following sequences,

i decide whether or not it is bounded and/or monotonic.

ii determine the limits in terms of the glb and lub.

a $\left\{ 1 + \frac{1}{n} \right\}$ **b** $\left\{ 3 - \frac{2}{n} \right\}$ **c** $\{4 - n\}$

d $\{2^{1-n}\}$ **e** $\left\{ \sin\left(\frac{1}{n}\right) \right\}$ **f** $\{-2^n\}$

From **Activity 2.3**, you have the following facts about monotonic sequences:

- 1** If a monotonic sequence is unbounded, then it diverges.
- 2** If a monotonic sequence is bounded, then it converges.
 - a** If it is bounded and increasing, then it converges to the least upper bound (lub) of the sequence.
 - b** If it is bounded and decreasing, then it converges to the greatest lower bound (glb) of the sequence.

Example 19 Show that the sequence $\left\{ \frac{n+1}{2n+3} \right\}$ converges.

Solution Observe that $\frac{n+1}{2n+3} = \frac{1}{2} - \frac{1}{2(2n+3)}$

The sequence $-\frac{1}{2(2n+3)}$ is increasing.

Hence, $\frac{1}{2} - \frac{1}{2(2n+3)}$ is increasing, with

$$\frac{2}{5} \leq \frac{n+1}{2n+3} < \frac{1}{2} \text{ for all } n \in \mathbb{N}. \text{ Explain!}$$

Therefore, $\left\{ \frac{n+1}{2n+3} \right\}$ is bounded and monotonic and hence it converges.

Also, $\lim_{n \rightarrow \infty} \frac{n+1}{2n+3} = \lim_{n \rightarrow \infty} \frac{1}{2} - \frac{1}{2(2n+3)} = \frac{1}{2}$. Why?

Thus, $\left\{ \frac{n+1}{2n+3} \right\}$ converges to the least upper bound of the sequence.

So far, the limit of a sequence $\{ a_n \}$ has been discussed. Your next task is to determine the limits of the sum, difference, product and quotient of two or more sequences.

Theorem 2.1

Let $\{a_n\}$ and $\{b_n\}$ be convergent sequences with $\lim_{n \rightarrow \infty} a_n = L$ and $\lim_{n \rightarrow \infty} b_n = M$. Then the sum $\{a_n + b_n\}$, the difference $\{a_n - b_n\}$, a constant multiple $\{ca_n\}$, the product $\{a_n b_n\}$, and the quotient $\left\{\frac{a_n}{b_n}\right\}$, provided that $M \neq 0$ and $b_n \neq 0$ for every n , are convergent with

- 1 $\lim_{n \rightarrow \infty} (a_n + b_n) = \lim_{n \rightarrow \infty} a_n + \lim_{n \rightarrow \infty} b_n = L + M$
- 2 $\lim_{n \rightarrow \infty} (a_n - b_n) = \lim_{n \rightarrow \infty} a_n - \lim_{n \rightarrow \infty} b_n = L - M$
- 3 $\lim_{n \rightarrow \infty} (ca_n) = c \lim_{n \rightarrow \infty} a_n = cL$ for a constant c .
- 4 $\lim_{n \rightarrow \infty} (a_n b_n) = \lim_{n \rightarrow \infty} a_n \cdot \lim_{n \rightarrow \infty} b_n = LM$
- 5 $\lim_{n \rightarrow \infty} \left(\frac{a_n}{b_n}\right) = \frac{\lim_{n \rightarrow \infty} a_n}{\lim_{n \rightarrow \infty} b_n} = \frac{L}{M}$
- 6 If $a_n \geq 0$, as $n \rightarrow \infty$, $\lim_{n \rightarrow \infty} \sqrt{a_n} = \sqrt{\lim_{n \rightarrow \infty} a_n} = \sqrt{L}$

Example 20 Evaluate $\lim_{n \rightarrow \infty} \left(8 + \frac{1}{n}\right)$

Solution Using **property 1**,

$$\lim_{n \rightarrow \infty} \left(8 + \frac{1}{n}\right) = \lim_{n \rightarrow \infty} 8 + \lim_{n \rightarrow \infty} \frac{1}{n} = 8 + 0 = 8$$

Example 21 Evaluate $\lim_{n \rightarrow \infty} \frac{n+2}{3n-5}$

Solution First, you divide the numerator and the denominator of the expression by n .

$$\begin{aligned} \text{Then, } \frac{n+2}{3n-5} &= \frac{\left(\frac{n+2}{n}\right)}{\frac{3n-5}{n}} = \frac{1 + \frac{2}{n}}{3 - \frac{5}{n}} \\ \Rightarrow \lim_{n \rightarrow \infty} \frac{n+2}{3n-5} &= \lim_{n \rightarrow \infty} \left(\frac{1 + \frac{2}{n}}{3 - \frac{5}{n}}\right) = \frac{\lim_{n \rightarrow \infty} \left(1 + \frac{2}{n}\right)}{\lim_{n \rightarrow \infty} \left(3 - \frac{5}{n}\right)} = \frac{\lim_{n \rightarrow \infty} (1) + \lim_{n \rightarrow \infty} \left(\frac{2}{n}\right)}{\lim_{n \rightarrow \infty} (3) - \lim_{n \rightarrow \infty} \left(\frac{5}{n}\right)} \\ &= \frac{1 + 2 \lim_{n \rightarrow \infty} \left(\frac{1}{n}\right)}{3 - 5 \lim_{n \rightarrow \infty} \left(\frac{1}{n}\right)} = \frac{1 + 2 \times 0}{3 - 5 \times 0} = \frac{1}{3} \end{aligned}$$

Example 22 Find $\lim_{n \rightarrow \infty} \frac{1}{n(n+3)}$

Solution Using partial fractions

$$\frac{1}{n(n+3)} = \frac{a}{n} + \frac{b}{n+3}, \text{ for constants } a \text{ and } b.$$

$$\begin{aligned} \Rightarrow \lim_{n \rightarrow \infty} \frac{1}{n(n+3)} &= \lim_{n \rightarrow \infty} \frac{a}{n} + \lim_{n \rightarrow \infty} \frac{b}{n+3} \\ &= a \lim_{n \rightarrow \infty} \frac{1}{n} + b \lim_{n \rightarrow \infty} \frac{1}{n+3} = a \times 0 + b \times 0 = 0 \end{aligned}$$

Example 23 Find $\lim_{n \rightarrow \infty} \frac{3n^2 + 4n + 1}{2n^2 + 7}$

Solution Since both the numerator and the denominator have the same degree, first divide both by n^2

$$\begin{aligned} \lim_{n \rightarrow \infty} \frac{3n^2 + 4n + 1}{2n^2 + 7} &= \lim_{n \rightarrow \infty} \frac{\frac{3n^2 + 4n + 1}{n^2}}{\frac{2n^2 + 7}{n^2}} = \lim_{n \rightarrow \infty} \left(\frac{3 + \frac{4}{n} + \frac{1}{n^2}}{2 + \frac{7}{n^2}} \right) = \frac{\lim_{n \rightarrow \infty} \left(3 + \frac{4}{n} + \frac{1}{n^2} \right)}{\lim_{n \rightarrow \infty} \left(2 + \frac{7}{n^2} \right)} \\ &= \frac{\lim_{n \rightarrow \infty} 3 + \lim_{n \rightarrow \infty} \frac{4}{n} + \lim_{n \rightarrow \infty} \frac{1}{n^2}}{\lim_{n \rightarrow \infty} 2 + \lim_{n \rightarrow \infty} \frac{7}{n^2}} = \frac{3 + 0 + 0}{2 + 0} = \frac{3}{2} \end{aligned}$$

Example 24 Evaluate $\lim_{n \rightarrow \infty} \left(\frac{2^{n+2}}{3^{n-3}} \right)$

Solution $\lim_{n \rightarrow \infty} \left(\frac{2^{n+2}}{3^{n-3}} \right) = \lim_{n \rightarrow \infty} \left(\frac{2^n \times 2^2}{3^n \times \frac{1}{27}} \right) = \lim_{n \rightarrow \infty} 108 \left(\frac{2}{3} \right)^n = 108 \times 0 = 0$

Example 25 Find the limit of the sequence whose terms are:

0.3, 0.33, 0.333, 0.3333, ...

Solution Clearly, the sequence converges to $0.\dot{3}$, if the terms continue by a series of 3's.

Moreover, the n^{th} term of the sequence can be expressed in terms of n as follows:

$$0.3 = \frac{3}{10} = 3 \left(\frac{9}{9 \times 10} \right) = 3 \left(\frac{10-1}{9 \times 10} \right)$$

$$0.33 = \frac{33}{100} = \frac{3}{10^2} \left(\frac{99}{9} \right) = \frac{3}{10^2} \left(\frac{10^2 - 1}{9} \right)$$

Also, $0.333 = \frac{3}{10^3} \left(\frac{10^3 - 1}{9} \right)$ so that

$$a_n = \frac{3}{10^n} \left(\frac{10^n - 1}{9} \right) \text{ or } a_n = \frac{3}{9} \left(\frac{10^n - 1}{10^n} \right) = \frac{1}{3} \left(1 - \frac{1}{10^n} \right)$$

Thus, $\lim_{n \rightarrow \infty} \frac{1}{3} \left(1 - \frac{1}{10^n} \right) = \lim_{n \rightarrow \infty} \left(\frac{1}{3} - \frac{1}{3} \times \frac{1}{10^n} \right) = \lim_{n \rightarrow \infty} \frac{1}{3} - \frac{1}{3} \lim_{n \rightarrow \infty} \frac{1}{10^n} = \frac{1}{3} - 0 = \frac{1}{3}$

Example 26 Evaluate $\lim_{n \rightarrow \infty} \frac{\sqrt{n^2 + 1} - 1}{\sqrt{n^2 + 1} + 1}$

Solution

$$\begin{aligned} \lim_{n \rightarrow \infty} \frac{\sqrt{n^2 + 1} - 1}{\sqrt{n^2 + 1} + 1} &= \lim_{n \rightarrow \infty} \left(\frac{\frac{\sqrt{n^2 + 1} - 1}{n}}{\frac{\sqrt{n^2 + 1} + 1}{n}} \right) = \lim_{n \rightarrow \infty} \frac{\sqrt{\frac{n^2 + 1}{n^2}} - \frac{1}{n}}{\sqrt{\frac{n^2 + 1}{n^2}} + \frac{1}{n}} \\ &= \lim_{n \rightarrow \infty} \frac{\sqrt{1 + \frac{1}{n^2}} - \frac{1}{n}}{\sqrt{1 + \frac{1}{n^2}} + \frac{1}{n}} \\ &= \frac{\lim_{n \rightarrow \infty} \sqrt{1 + \frac{1}{n^2}} - \lim_{n \rightarrow \infty} \frac{1}{n}}{\lim_{n \rightarrow \infty} \sqrt{1 + \frac{1}{n^2}} + \lim_{n \rightarrow \infty} \frac{1}{n}} = \frac{\sqrt{\lim_{n \rightarrow \infty} \left(1 + \frac{1}{n^2} \right)} - 0}{\sqrt{\lim_{n \rightarrow \infty} \left(1 + \frac{1}{n^2} \right)} + 0} = 1 \end{aligned}$$

Exercise 2.4

Evaluate each of the limits given in 1 – 18.

1 $\lim_{n \rightarrow \infty} \left(\frac{1}{n} + \frac{3}{n+2} \right)$

2 $\lim_{n \rightarrow \infty} \left(\frac{3^n + 2^n}{6^n} \right)$

3 $\lim_{n \rightarrow \infty} \left((\sqrt{3})^n \right)$

4 $\lim_{n \rightarrow \infty} \left(\frac{25}{n+10} \right)$

5 $\lim_{n \rightarrow \infty} \left(\frac{n^2 + 1}{30n + 100} \right)$

6 $\lim_{n \rightarrow \infty} \left(\frac{1+n+n^2}{n} \right)$

7 $\lim_{n \rightarrow \infty} \left(-\frac{3}{5} \right)^n$

8 $\lim_{n \rightarrow \infty} \left(20 + \left(-\frac{1}{3} \right)^n \right)$

9 $\lim_{n \rightarrow \infty} \left(\left(\frac{1}{3} \right)^n - n \right)$

10 $\lim_{n \rightarrow \infty} \frac{(3n+1)^2}{2n^2 + 3n + 1}$

11 $\lim_{n \rightarrow \infty} \frac{\sqrt{n^2 + 5}}{n + 1}$

12 $\lim_{n \rightarrow \infty} \left(\frac{2n+3}{2n+5} \times \frac{5n-2}{6n+1} \right)$

- 13 $\lim_{n \rightarrow \infty} \left(\frac{1+2^2+3^2+\dots+n^2}{n^3} \right)$ 14 $\lim_{n \rightarrow \infty} (ne^{-n})$ 15 $\lim_{n \rightarrow \infty} \left(\frac{1}{\sqrt{n}} - \frac{1}{\sqrt{n+1}} \right)$
- 16 $\lim_{n \rightarrow \infty} \left(\frac{n+3}{1+\sqrt{n}} \right)$ 17 $\lim_{n \rightarrow \infty} \left(\frac{1}{2} \right)^{1-2n}$ 18 $\lim_{n \rightarrow \infty} \frac{\sqrt{n^2+1}-3}{n+2}$
- 19 Give examples of sequences $\{a_n\}$ and $\{b_n\}$ such that
- a $\lim_{n \rightarrow \infty} (a_n + b_n)$ exists but neither $\lim_{n \rightarrow \infty} a_n$ nor $\lim_{n \rightarrow \infty} b_n$ exists.
- b $\lim_{n \rightarrow \infty} (a_n b_n)$ exists but neither $\lim_{n \rightarrow \infty} a_n$ nor $\lim_{n \rightarrow \infty} b_n$ exists.
- 20 Let $a_n = 2^n$ and $b_n = n!$ Evaluate $\lim_{n \rightarrow \infty} \frac{a_n}{b_n}$

2.2 LIMITS OF FUNCTIONS

In this topic, you will use functions such as polynomial, rational, exponential, logarithmic, absolute value, trigonometric and other piece-wise defined functions in order to introduce the concept "limit of a function".

We will see different techniques of finding the limit of a function at a point such as cancelling common factors in rational expressions, like $\frac{(x-2)(x+5)}{(x-2)(x+1)}$, for $x \neq 2$, rationalization, like

$\frac{(\sqrt{x}-1)}{x-1} \cdot \frac{\sqrt{x}+1}{\sqrt{x}+1}$, graphs, tables of values and other properties.

Limits of Functions at a Point

ACTIVITY 2.4

- 1 Use the graph to answer the questions below it.

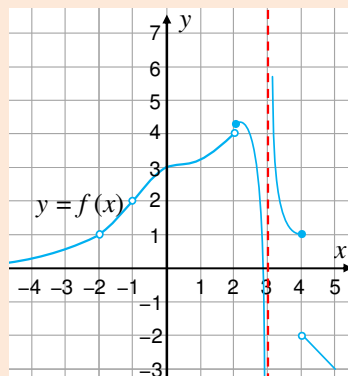

Figure 2.8



- i** What is the domain of f ?
- ii** Give the values of
 - a** $f(-2)$ **b** $f(-1)$ **c** $f(2)$ **d** $f(3)$ **e** $f(4)$
- iii** What number does $f(x)$ approach to as x approaches
 - a** $-\infty$?
 - b** -2 ?
 - c** -1 from the right?
 - d** -1 from the left?
 - e** 0 ?
 - f** 2 from the right?
 - g** 2 from the left?
 - h** 4 from the right?
 - i** 4 from the left?
 - j** ∞ ?

2 Explain the difference between the limits $\lim_{n \rightarrow \infty} \frac{1}{n}$ and $\lim_{x \rightarrow \infty} \frac{1}{x}$, where $n \in \mathbb{N}$ and $x \in \mathbb{R}$.

Definition 2.6 The intuitive definition of the limit of a function at a point

Let $y = f(x)$ be a function defined on an interval surrounding $x_0 \in \mathbb{R}$ (but f need not be defined at $x = x_0$). If $f(x)$ gets closer and closer to a single real number L as x gets closer and closer to (but not equal to) x_0 , then we say that the limit of $f(x)$ as x approaches x_0 is L .

Symbolically, this is written as

$$\lim_{x \rightarrow x_0} f(x) = L$$

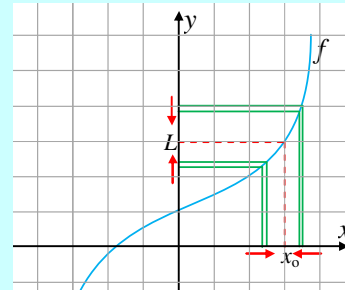

Figure 2.9

Example 1 Let $f(x) = x$. Then $\lim_{x \rightarrow x_0} f(x) = x_0$

Example 2 Let $f(x) = \frac{x^2 - 4}{x - 2}$. Evaluate $\lim_{x \rightarrow 2} f(x)$

Solution Look at the graph of

$$f(x) = \frac{x^2 - 4}{x - 2} = \begin{cases} x + 2, & \text{if } x \neq 2 \\ \text{---}, & \text{if } x = 2 \end{cases}$$

As x gets closer and closer to 2, $f(x)$ gets closer and closer to 4.

$$\Rightarrow \lim_{x \rightarrow 2} f(x) = \lim_{x \rightarrow 2} (x + 2) = 4$$

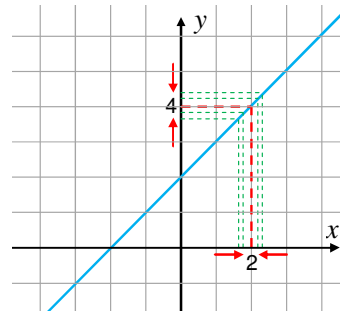

Figure 2.10

Note:

✓ If $f(x)$ approaches to different numbers as x approaches to x_0 from the right and from the left, then we conclude that $\lim_{x \rightarrow x_0} f(x)$ does not exist.

ACTIVITY 2.5



- 1 Explain the difference between $\lim_{x \rightarrow a} f(x)$ and $f(a)$.
- 2 What happens to $\lim_{x \rightarrow a} f(x)$, if $f(x)$ approaches to different numbers as x approaches to a from the right and from the left? Explain this by producing examples.
- 3 The limit of a function $f(x)$ as x approaches a from the right is represented by the symbol $\lim_{x \rightarrow a^+} f(x)$ and from the left by $\lim_{x \rightarrow a^-} f(x)$.
 Are $\lim_{x \rightarrow a^+} f(x)$ and $\lim_{x \rightarrow a^-} f(x)$ the same for every function f ?
 What can you say about $\lim_{x \rightarrow a} f(x)$, if $\lim_{x \rightarrow a^+} f(x) = \lim_{x \rightarrow a^-} f(x)$?
- 4 Consider the following graph of a function f .

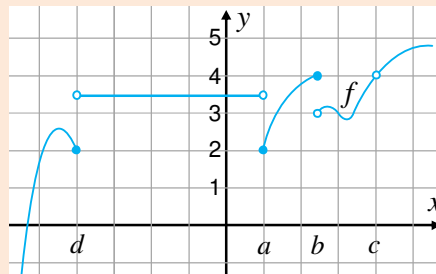

Figure 2.11

Evaluate the following limits from the graph.

- | | | | | | | | |
|----------|---------------------------------|----------|---------------------------------|----------|---------------------------------|----------|---------------------------------|
| a | $\lim_{x \rightarrow a^+} f(x)$ | b | $\lim_{x \rightarrow d^+} f(x)$ | c | $\lim_{x \rightarrow d} f(x)$ | d | $\lim_{x \rightarrow a^-} f(x)$ |
| e | $\lim_{x \rightarrow d^-} f(x)$ | f | $\lim_{x \rightarrow b^+} f(x)$ | g | $\lim_{x \rightarrow b^-} f(x)$ | h | $\lim_{x \rightarrow c^+} f(x)$ |

Example 3 Evaluate each of the following limits.

- | | | | | | |
|----------|---|----------|--|----------|---|
| a | $\lim_{x \rightarrow 2} (2x-1)$ | b | $\lim_{x \rightarrow 0} \frac{ x }{x}$ | c | $\lim_{x \rightarrow 3} \frac{x^2 - 5x + 2}{x + 4}$ |
| d | $\lim_{x \rightarrow -2} \frac{x^2 + x - 2}{x + 2}$ | e | $\lim_{x \rightarrow 1} \frac{x}{x^2 - 1}$ | f | $\lim_{x \rightarrow \frac{\pi}{2}^+} \tan x$ |

Solution

a $\lim_{x \rightarrow 2} (2x-1) = 2(2) - 1 = 3$

b $\frac{|x|}{x} = \begin{cases} 1, & \text{if } x > 0 \\ \text{undefined}, & \text{if } x = 0 \\ -1, & \text{if } x < 0 \end{cases}$

$\Rightarrow \lim_{x \rightarrow 0} f(x)$ doesn't exist.

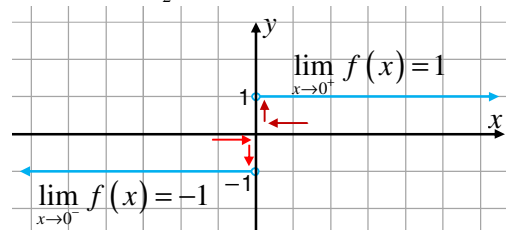

Figure 2.12

c Look at the following tables of values (taken up to 4 decimal places)

x	2.9	2.99	2.999	3.1	3.01	3.001	...	3
$\frac{x^2 - 5x + 2}{x + 4}$	-0.5927	-0.5736	-0.5717	-0.5479	-0.56917	-0.5712		

To which number does $f(x)$ approach as x approaches to 3?

$$\lim_{x \rightarrow 3} \frac{x^2 - 5x + 2}{x + 4} = -\frac{4}{7} = -0.5714$$

d $\frac{x^2 + x - 2}{x + 2} = \frac{(x+2)(x-1)}{x+2} = x - 1; x \neq -2.$

$$\lim_{x \rightarrow -2} \frac{x^2 + x - 2}{x + 2} = \lim_{x \rightarrow -2} (x - 1) = -3.$$

Look at **Figures 2.13** and **2.14** to answer **problems e** and **f**.

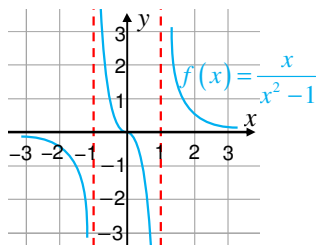

Figures 2.13

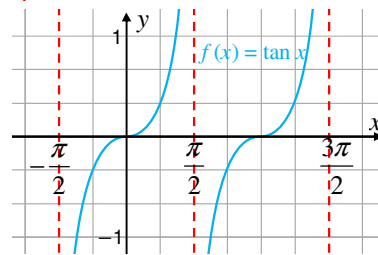

Figures 2.14

e $\lim_{x \rightarrow 1^+} \frac{x}{x^2 - 1} = \infty; \lim_{x \rightarrow 1^-} \frac{x}{x^2 - 1} = -\infty \Rightarrow \lim_{x \rightarrow 1} \frac{x}{x^2 - 1}$ doesn't exist.

f $\lim_{x \rightarrow \frac{\pi}{2}^+} (\tan x) = -\infty; \lim_{x \rightarrow \frac{\pi}{2}^-} (\tan x) = \infty \Rightarrow \lim_{x \rightarrow \frac{\pi}{2}} (\tan x)$ doesn't exist.

Example 4 The limit of a constant function at $x = a$ is the constant itself.

To verify this:

Let $f(x) = c$. Clearly, $f(x)$ is approaching to c as x is approaching any number, so that $\lim_{x \rightarrow a} c = c$.

Example 5 The limit of the identity function as $x \rightarrow a$ is a . That is, $\lim_{x \rightarrow a} x = a$.

Example 6 Let $f(x) = \begin{cases} 0, & \text{if } x \in \mathbb{Z} \\ 1, & \text{if } x \notin \mathbb{Z} \end{cases}$. Evaluate

a $\lim_{x \rightarrow -2} f(x)$ **b** $\lim_{x \rightarrow 0.3} f(x)$

Solution Sketch the graph of f (see **Figure 2.15**)

a $\lim_{x \rightarrow -2} f(x) = 1$, but $f(-2) = 0$.

b $\lim_{x \rightarrow 0.3} f(x) = 1$

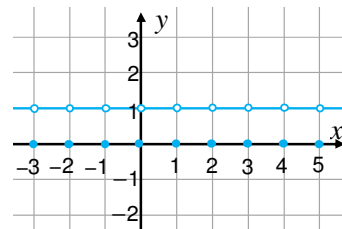

Figure 2.15

Is $\lim_{x \rightarrow c} f(x) = 1$ for all $c \in \mathbb{R}$?

What can you say about c if $\lim_{x \rightarrow c} f(x) = f(c) = 1$?

Clearly, c must not be an integer.

Exercise 2.5

Use graphs or calculators to determine the limits in exercises 1 – 15.

1 $\lim_{x \rightarrow 4} (5x + 7)$

2 $\lim_{x \rightarrow 0} \sin x$

3 $\lim_{x \rightarrow \frac{1}{3}} \frac{1}{(3x-1)}$

4 $\lim_{x \rightarrow 0} (2^x)$

5 $\lim_{x \rightarrow 0} \frac{1}{e^x - 1}$

6 $\lim_{x \rightarrow 1} \frac{x-1}{x^2 + x - 2}$

7 $\lim_{x \rightarrow 2} \frac{x-2}{x^2 - x - 2}$

8 $\lim_{x \rightarrow 3} \frac{x^3 + 27}{x + 3}$

9 $\lim_{x \rightarrow 1} \frac{x^4 - 1}{x^6 - 1}$

10 $\lim_{x \rightarrow 1} \frac{\sqrt[3]{x} - 1}{x - 1}$

11 $\lim_{x \rightarrow 4} \frac{\sqrt{x} - 2}{x - 4}$

12 $\lim_{x \rightarrow 0} \frac{x - 4|x|}{x}$

13 $\lim_{x \rightarrow 5} \frac{5x - x^2}{x - 5}$

14 $\lim_{x \rightarrow 0} \frac{x^3}{|x|}$

15 $\lim_{x \rightarrow -2} \frac{x^2 - 5x - 14}{x^2 - 4}$

16 Discuss the following point in groups. Is the limit of the sum of two functions at a point the same as the sum of the limits at the given point? Justify your answer by producing several examples.

Basic limit theorems

Suppose $\lim_{x \rightarrow a} f(x)$ and $\lim_{x \rightarrow a} g(x)$ exist and $k \in \mathbb{R}$.

Then, $\lim_{x \rightarrow a} (f(x) + g(x))$, $\lim_{x \rightarrow a} (f(x) - g(x))$, $\lim_{x \rightarrow a} kf(x)$, $\lim_{x \rightarrow a} (fg)(x)$, $\lim_{x \rightarrow a} \left(\frac{f}{g}\right)(x)$,

provided that $\lim_{x \rightarrow a} g(x) \neq 0$, exist and

1 $\lim_{x \rightarrow a} (f(x) + g(x)) = \lim_{x \rightarrow a} f(x) + \lim_{x \rightarrow a} g(x)$

2 $\lim_{x \rightarrow a} (f(x) - g(x)) = \lim_{x \rightarrow a} f(x) - \lim_{x \rightarrow a} g(x)$

3 $\lim_{x \rightarrow a} kf(x) = k \lim_{x \rightarrow a} f(x)$

4 $\lim_{x \rightarrow a} (fg)(x) = \lim_{x \rightarrow a} f(x) \cdot \lim_{x \rightarrow a} g(x)$

5 $\lim_{x \rightarrow a} \left(\frac{f}{g}\right)(x) = \frac{\lim_{x \rightarrow a} f(x)}{\lim_{x \rightarrow a} g(x)}$

6 $\lim_{x \rightarrow a} \sqrt{f(x)} = \sqrt{\lim_{x \rightarrow a} f(x)}$, provided that $f(x) \geq 0$ for x near a .

See how to apply the **limit theorems** in the following example.

$$\begin{aligned}
 \text{Example 7 } \lim_{x \rightarrow 2} \left(x^3 + 4x^2 - \frac{1}{x} + 7x + 11 \right) \\
 &= \lim_{x \rightarrow 2} x^3 + 4 \lim_{x \rightarrow 2} x^2 - \lim_{x \rightarrow 2} \left(\frac{1}{x} \right) + 7 \lim_{x \rightarrow 2} x + \lim_{x \rightarrow 2} (11) \\
 &= (2)^3 + 4 \left(\lim_{x \rightarrow 2} x \right)^2 - \frac{\lim_{x \rightarrow 2} (1)}{\lim_{x \rightarrow 2} (x)} + 7(2) + 11 \\
 &= 2^3 + 4 \times 2^2 - \frac{1}{2} + 25 = 48.5
 \end{aligned}$$

The limit of a polynomial function

Suppose $p(x)$ is a polynomial, then $\lim_{x \rightarrow c} p(x) = p(c)$. *Explain!*

$$\text{Example 8 } \lim_{x \rightarrow 3} (x^4 - 2x^3 + 5x^2 + 7x + 1) = 3^4 - 2(3)^3 + 5(3)^2 + 7(3) + 1 = 94$$

Theorem 2.2

Let f and g be functions. Suppose $\lim_{x \rightarrow a} f(x)$ and $\lim_{x \rightarrow a} g(x)$ exist and $f(x) = g(x)$, $\forall x \neq a$.

Then $\lim_{x \rightarrow a} f(x) = \lim_{x \rightarrow a} g(x)$.

$$\text{Example 9 } \text{Find } \lim_{x \rightarrow 1} \frac{x^2 - 1}{x - 1}.$$

$$\text{Solution } \frac{x^2 - 1}{x - 1} = x + 1; \text{ for } x \neq 1. \text{ Let } f(x) = \frac{x^2 - 1}{x - 1} \text{ and } g(x) = x + 1.$$

$$f(x) = g(x), \forall x \neq 1. \text{ Then } \lim_{x \rightarrow 1} f(x) = \lim_{x \rightarrow 1} g(x) \Rightarrow \lim_{x \rightarrow 1} \frac{x^2 - 1}{x - 1} = \lim_{x \rightarrow 1} (x + 1) = 2.$$

$$\text{Example 10 } \text{Find } \lim_{x \rightarrow 1} \frac{x - 1}{\sqrt{x} - 1}.$$

$$\text{Solution } \text{What happens to } \lim_{x \rightarrow 1} \frac{x - 1}{\sqrt{x} - 1} \text{ when } x = 1? \text{ Is the result defined?}$$

Rewrite the expression by rationalizing the denominator.

$$\begin{aligned}
 \frac{x - 1}{\sqrt{x} - 1} &= \frac{(x - 1)(\sqrt{x} + 1)}{x - 1} \\
 &\Rightarrow \lim_{x \rightarrow 1} \frac{x - 1}{\sqrt{x} - 1} = \lim_{x \rightarrow 1} (\sqrt{x} + 1) = 2
 \end{aligned}$$

$$\text{Example 11 } \text{Evaluate } \lim_{x \rightarrow 3} \frac{x^3 + 3x^2 - x - 3}{4x^3 + 12x^2 - x - 3}$$

$$\text{Solution } x^3 + 3x^2 - x - 3 = x^2(x + 3) - (x + 3) = (x^2 - 1)(x + 3)$$

$$4x^3 + 12x^2 - x - 3 = 4x^2(x+3) - (x+3) = (4x^2 - 1)(x+3)$$

$$\Rightarrow \lim_{x \rightarrow -3} \frac{x^3 + 3x^2 - x - 3}{4x^3 + 12x^2 - x - 3} = \lim_{x \rightarrow -3} \frac{(x^2 - 1)(x+3)}{(4x^2 - 1)(x+3)} = \lim_{x \rightarrow -3} \frac{x^2 - 1}{4x^2 - 1} = \frac{8}{35}$$

Example 12 Evaluate $\lim_{x \rightarrow 2} \frac{\frac{2}{x} - 1}{x^3 - 8}$.

Solution $\frac{\frac{2}{x} - 1}{x^3 - 8} = \frac{\left(\frac{2-x}{x}\right)}{(x-2)(x^2 + 2x + 4)} = -\frac{1}{x(x^2 + 2x + 4)}; x \neq 0, 2$

$$\Rightarrow \Rightarrow \lim_{x \rightarrow 2} \frac{x}{x^3 - 8} = -\lim_{x \rightarrow 2} \frac{1}{x(x^2 + 2x + 4)} = -\frac{1}{24}$$

Example 13 Let $f(x) = \sqrt{2-x}$. Simplify the expression $\frac{f(x) - f(1)}{x-1}$ and

evaluate $\lim_{x \rightarrow 1} \frac{f(x) - f(1)}{x-1}$.

Solution $\lim_{x \rightarrow 1} \frac{f(x) - f(1)}{x-1} = \lim_{x \rightarrow 1} \frac{\sqrt{2-x} - 1}{x-1} = \lim_{x \rightarrow 1} \frac{-1}{1 + \sqrt{2-x}} = -\frac{1}{2}$.

Example 14 If $\lim_{x \rightarrow x_0} (f(x) + g(x))$ exists, do the limit $\lim_{x \rightarrow x_0} f(x)$ and $\lim_{x \rightarrow x_0} g(x)$ exist?

Solution Take, for example, $f(x) = \frac{1}{x-1}$ and $g(x) = \frac{2}{1-x^2}$.

Do $\lim_{x \rightarrow 1} f(x)$ and $\lim_{x \rightarrow 1} g(x)$ exist? Evaluate $\lim_{x \rightarrow 1} (f+g)(x)$.

$\lim_{x \rightarrow 1} f(x)$ and $\lim_{x \rightarrow 1} g(x)$ both don't exist. But

$$\lim_{x \rightarrow 1} (f(x) + g(x)) = \lim_{x \rightarrow 1} \left(\frac{1}{x-1} + \frac{2}{1-x^2} \right) = \lim_{x \rightarrow 1} \frac{1-x}{1-x^2} = \lim_{x \rightarrow 1} \frac{1}{x+1} = \frac{1}{2}$$

Example 15 Find $\lim_{x \rightarrow 4} \frac{x-4}{\sqrt{x}-2}$

Solution $\lim_{x \rightarrow 4} \frac{x-4}{\sqrt{x}-2} = \lim_{x \rightarrow 4} \frac{(x-4)(\sqrt{x}+2)}{(\sqrt{x}-2)(\sqrt{x}+2)} = \lim_{x \rightarrow 4} \frac{(x-4)(\sqrt{x}+2)}{x-4}$

$$= \lim_{x \rightarrow 4} (\sqrt{x}+2) = 4$$

Example 16 Let $f(x) = \sqrt{x}$. Find $\lim_{h \rightarrow 0} \frac{f(4+h) - f(4)}{h}$.

Solution

$$\begin{aligned}\lim_{h \rightarrow 0} \frac{f(4+h) - f(4)}{h} &= \lim_{h \rightarrow 0} \frac{\sqrt{4+h} - 2}{h} = \lim_{h \rightarrow 0} \left[\frac{\sqrt{4+h} - 2}{h} \cdot \frac{\sqrt{4+h} + 2}{\sqrt{4+h} + 2} \right] \\ &= \lim_{h \rightarrow 0} \left(\frac{1}{\sqrt{4+h} + 2} \right) = \frac{1}{4}\end{aligned}$$

Example 17 Evaluate $\lim_{x \rightarrow 1} \sqrt{x^3 + x^2 - 6x + 5}$

Solution $x^3 + x^2 - 6x + 5 \geq 0$ for x near 1.

$$\Rightarrow \lim_{x \rightarrow 1} \sqrt{x^3 + x^2 - 6x + 5} = \sqrt{\lim_{x \rightarrow 1} (x^3 + x^2 - 6x + 5)} = \sqrt{1} = 1$$

Example 18 Find $\lim_{x \rightarrow 0} \frac{\sqrt{5-x} - \sqrt{5}}{x}$

Solution

$$\begin{aligned}\lim_{x \rightarrow 0} \frac{\sqrt{5-x} - \sqrt{5}}{x} &= \lim_{x \rightarrow 0} \frac{(\sqrt{5-x} - \sqrt{5})(\sqrt{5-x} + \sqrt{5})}{x(\sqrt{5-x} + \sqrt{5})} \\ &= \lim_{x \rightarrow 0} \frac{5-x-5}{x(\sqrt{5-x} + \sqrt{5})} = -\lim_{x \rightarrow 0} \frac{1}{\sqrt{5-x} + \sqrt{5}} = -\frac{1}{2\sqrt{5}}\end{aligned}$$

Example 19 Find $\lim_{x \rightarrow 7} \frac{\frac{1}{x+7} - \frac{1}{14}}{x-7}$.

Solution

$$\begin{aligned}\lim_{x \rightarrow 7} \frac{\frac{1}{x+7} - \frac{1}{14}}{x-7} &= \lim_{x \rightarrow 7} \frac{14 - (x+7)}{14(x+7)(x-7)} = \lim_{x \rightarrow 7} \left(\frac{7-x}{x-7} \cdot \frac{1}{14(x+7)} \right) \\ &= -\lim_{x \rightarrow 7} \frac{1}{14(x+7)} = -\frac{1}{196}\end{aligned}$$

Example 20 Evaluate $\lim_{x \rightarrow 3} \frac{\sqrt{1+\sqrt{4+x}} - \sqrt{2}}{x+3}$.

Solution

$$\begin{aligned}\lim_{x \rightarrow 3} \frac{\sqrt{1+\sqrt{4+x}} - \sqrt{2}}{x+3} &= \frac{\sqrt{1+\sqrt{4+x}} - \sqrt{2}}{x+3} \cdot \frac{\sqrt{1+\sqrt{4+x}} + \sqrt{2}}{\sqrt{1+\sqrt{4+x}} + \sqrt{2}} \\ &= \frac{\sqrt{4+x} - 1}{x+3} \cdot \frac{1}{\sqrt{1+\sqrt{4+x}} + \sqrt{2}} \quad (\text{Explain!}) \\ &= \frac{x+3}{x+3} \cdot \frac{1}{(\sqrt{4+x} + 1)(\sqrt{1+\sqrt{4+x}} + \sqrt{2})} \quad (\text{Explain!}) \\ \Rightarrow \lim_{x \rightarrow 3} \frac{\sqrt{1+\sqrt{4+x}} - \sqrt{2}}{x+3} &= \frac{\sqrt{2}}{8} \quad (\text{Explain!})\end{aligned}$$

Exercise 2.6

1 Use the following graph of the function f to determine each of the limits.

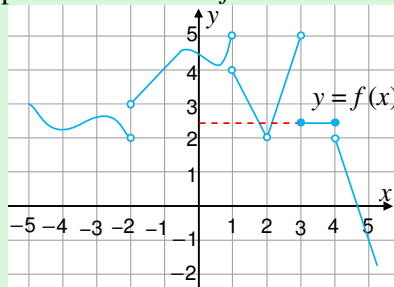

Figure 2.16

- a** $\lim_{x \rightarrow 1^-} f(x)$ **b** $\lim_{x \rightarrow 2} f(x)$ **c** $\lim_{x \rightarrow -2} f(x)$
d $\lim_{x \rightarrow 1^+} f(x)$ **e** $\lim_{x \rightarrow 4^-} f(x)$ **f** $\lim_{x \rightarrow 3} f(x)$

2 Let $f(x) = \begin{cases} 1 - x^2, & \text{if } -1 < x < 2 \\ -3 & \text{if } x = -1 \\ -x - 1, & \text{if } x < -1 \\ x - 5, & \text{if } x \geq 2 \end{cases}$

Sketch the graph of f and determine each of the following limits.

- a** $\lim_{x \rightarrow -1} f(x)$ **b** $\lim_{x \rightarrow 2} f(x)$ **c** $\lim_{x \rightarrow 5} f(x)$ **d** $\lim_{x \rightarrow 3} f(x)$

3 Suppose that f , g and h are functions with $\lim_{x \rightarrow 2} f(x) = 7$, $\lim_{x \rightarrow 2} g(x) = -4$ and

$$\lim_{x \rightarrow 2} h(x) = \frac{3}{5}, \text{ evaluate}$$

- a** $\lim_{x \rightarrow 2} (f(x) + g(x))$ **b** $\lim_{x \rightarrow 2} ((fg)(x) - 3h(x))$

c $\lim_{x \rightarrow 2} \frac{f(x)g(x)h(x)}{f(x) + g(x) - 5h(x)}$

4 Determine each of the following limits.

a $\lim_{x \rightarrow 3} \frac{x-3}{\sqrt{x^2-6x+9}}$ **b** $\lim_{x \rightarrow 0} \frac{\sqrt{x^2+1}-1}{x^2}$ **c** $\lim_{x \rightarrow \frac{1}{3}} \frac{x+1}{3x-1}$

d $\lim_{x \rightarrow -2} \frac{x^3+8}{x+2}$ **e** $\lim_{x \rightarrow 0} \frac{x^3}{|x|+x}$ **f** $\lim_{x \rightarrow -5} \frac{x^2+x-20}{x^2+4x-5}$

g $\lim_{x \rightarrow 0} \frac{\sin x + 1}{x + \cos x}$ **h** $\lim_{x \rightarrow 2} \frac{\sqrt{x} - \sqrt{2}}{x - 2}$ **i** $\lim_{x \rightarrow 2} \frac{\sqrt{x-2}\sqrt{x+1}-1}{\sqrt{x}-2}$

j $\lim_{x \rightarrow 1} \frac{\sqrt{x-1} + \sqrt{x}-1}{\sqrt{x^2-1}}$

Limits at infinity

Limits as x approaches ∞

ACTIVITY 2.6



- 1** Using the concept of limits of sequences of numbers, evaluate each of the following limits at infinity.

a $\lim_{x \rightarrow \infty} \frac{1}{x}$ **b** $\lim_{x \rightarrow \infty} \frac{3x-1}{x+5}$ **c** $\lim_{x \rightarrow \infty} \frac{x^2+1}{x-1}$

- 2** Let $f(x) = \frac{p(x)}{q(x)}$ be a rational function.

a If degree of $p(x) =$ degree of $q(x)$, evaluate $\lim_{x \rightarrow \infty} \frac{p(x)}{q(x)}$ in terms of the leading coefficients of $p(x)$ and $q(x)$.

b If degree of $p(x) <$ degree of $q(x)$, discuss how to evaluate $\lim_{x \rightarrow \infty} \frac{p(x)}{q(x)}$.

c Do you see a relationship between these limits and horizontal asymptotes of rational functions?

Definition 2.7

Let f be a function and L be a real number.

If $f(x)$ gets closer to L as x increases without bound, then L is said to be the limit of $f(x)$ as x approaches to infinity.

This statement is expressed symbolically by $\lim_{x \rightarrow \infty} f(x) = L$

Example 21 Evaluate $\lim_{x \rightarrow \infty} \frac{3x^2 - 5x + 4}{2x^2 + 4}$

Solution You apply the technique which are used in evaluating limits of number sequences. i.e. divide the numerator and denominator by x^2 (the highest power monomial).

$$\lim_{x \rightarrow \infty} \left(\frac{3x^2 - 5x + 4}{2x^2 + 4} \right) = \lim_{x \rightarrow \infty} \left(\frac{\frac{3x^2 - 5x + 4}{x^2}}{\frac{2x^2 + 4}{x^2}} \right) = \frac{\lim_{x \rightarrow \infty} \left(3 - \frac{5}{x} + \frac{4}{x^2} \right)}{\lim_{x \rightarrow \infty} \left(2 + \frac{4}{x^2} \right)} = \frac{3 - 0 + 0}{2 + 0} = \frac{3}{2}$$

Example 22 Evaluate $\lim_{x \rightarrow \infty} \left(\frac{1-3x}{6x+5} + \frac{2x+1}{x^2+7x+1} \right)$

Solution

$$\lim_{x \rightarrow \infty} \left(\frac{1-3x}{6x+5} + \frac{2x+1}{x^2+7x+1} \right) = \lim_{x \rightarrow \infty} \left(\frac{1-3x}{6x+5} \right) + \lim_{x \rightarrow \infty} \frac{2x+1}{x^2+7x+1} = \lim_{x \rightarrow \infty} \frac{\frac{1}{6} - \frac{3}{5}}{6 + \frac{5}{x}} + 0 = -\frac{1}{2}.$$

Non-existence of limits

In the previous topic, you already saw one condition in which a limit fails to exist.

For example, $\lim_{x \rightarrow 0} \frac{|x|}{x}$, does not exist, as the limit from the left and the right do not agree.

Do you see any other condition in which a limit fails to exist?

Consider $f(x) = \sin\left(\frac{\pi}{x}\right)$.

You know that $y = \sin x$ has one complete cycle on the interval 2π to 4π . As $\frac{\pi}{x}$ moves

from 2π to 4π , x moves from $\frac{\pi}{2\pi}$ to $\frac{\pi}{4\pi}$ which is $\frac{1}{2}$ to $\frac{1}{4}$. Therefore, the graph of f is

a complete cycle on the interval $\left[\frac{1}{4}, \frac{1}{2}\right]$, similarly there is a complete cycle on

intervals $\left[\frac{1}{6}, \frac{1}{4}\right]$, $\left[\frac{1}{8}, \frac{1}{6}\right]$, and so on.

Hence, the graph of f gets more and more crowded as x - approaches 0. i.e. changes too frequently between -1 and 1 , as x approaches 0. The graph does not settle down. That is, it does not approach a fixed point. Instead, it oscillates between -1 and 1 . Therefore,

$\lim_{x \rightarrow 0} \sin\left(\frac{\pi}{x}\right)$ does not exist. This is the second condition in which a limit fails to exist.

The following is the graph of $f(x) = \sin\left(\frac{\pi}{x}\right)$ showing the non-existence of $\lim_{x \rightarrow 0} \sin\left(\frac{\pi}{x}\right)$.

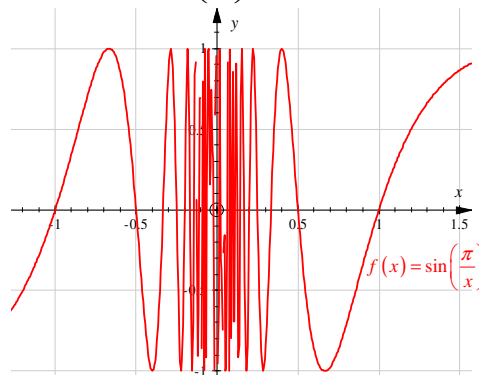

Figure 2.17

One side limits

ACTIVITY 2.7



- 1 Sketch the graph of $f(x) = \sqrt{x}$ and $g(x) = \sqrt{-x}$

Evaluate each of the following one-sided limits based on your knowledge of limit of a function f at a point $x = a$ as x approaches a from the right, $\lim_{x \rightarrow a^+} f(x)$ and as x approaches a from the left, $\lim_{x \rightarrow a^-} f(x)$.

a $\lim_{x \rightarrow 0^+} f(x)$ **b** $\lim_{x \rightarrow 0^-} f(x)$ **c** $\lim_{x \rightarrow 0^+} g(x)$ **d** $\lim_{x \rightarrow 0^-} g(x)$

- 2 Use the following graph of a function f to evaluate the one side limit.

a $\lim_{x \rightarrow 1^+} f(x)$ **b** $\lim_{x \rightarrow 1^-} f(x)$ **c** $\lim_{x \rightarrow 3^+} f(x)$
d $\lim_{x \rightarrow 3^-} f(x)$ **e** $\lim_{x \rightarrow 4^+} f(x)$ **f** $\lim_{x \rightarrow 4^-} f(x)$
g $\lim_{x \rightarrow 2^+} f(x)$ **h** $\lim_{x \rightarrow 2^-} f(x)$

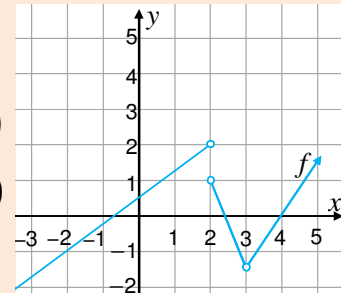

Figure 2.18

Definition 2.8

1 Right Hand Limit

Let f be defined on some open interval (a, c) . Suppose $f(x)$ approaches a number L as x approaches a from the right, then L is said to be the right hand limit of f at $x = a$.

This is abbreviated as: $\lim_{x \rightarrow a^+} f(x) = L$

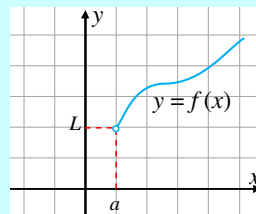

a

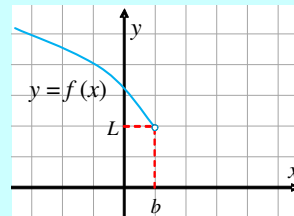

b

Figure 2.19

2 Left Hand Limit

Let f be defined on some open interval (c, b) . Suppose $f(x)$ approaches a number L as x approaches b from the left. Then L is said to be the left hand limit of f at $x = b$.

This is abbreviated by $\lim_{x \rightarrow b^-} f(x) = L$

Example 23 Let $f(x) = \sqrt{x-4}$.

Find $\lim_{x \rightarrow 4^+} f(x)$

Solution $\lim_{x \rightarrow 4^+} \sqrt{x-4} = 0$

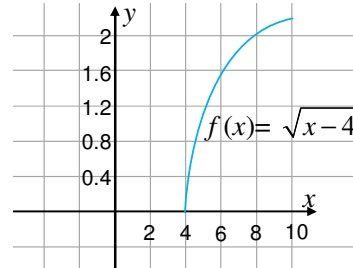

Figure 2.20

Example 24 Evaluate

a $\lim_{x \rightarrow 3^+} \sqrt{9-x^2}$ **b** $\lim_{x \rightarrow 3^-} \sqrt{9-x^2}$

c $\lim_{x \rightarrow -3^+} \sqrt{9-x^2}$ **d** $\lim_{x \rightarrow -3^-} \sqrt{9-x^2}$

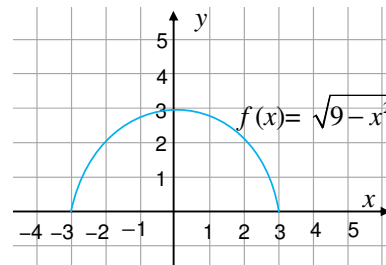

Figure 2.21

Solution Look at the following orders:

$3^- < 3 < 3^+$ and $-3^- < -3 < -3^+$

$(3^-)^2 = 9^-$ and $(3^+)^2 = 9^+$

$(-3^-)^2 = 9^+$ and $(-3^+)^2 = 9^-$

As $x \rightarrow 3^+$, $9-x^2 \rightarrow 0^-$ and, as $x \rightarrow 3^-$, $9-x^2 \rightarrow 0^+$

Therefore,

a $\lim_{x \rightarrow 3^+} \sqrt{9-x^2}$ doesn't exist

b $\lim_{x \rightarrow 3^-} \sqrt{9-x^2} = 0$

c $\lim_{x \rightarrow -3^+} \sqrt{9-x^2} = 0$

d $\lim_{x \rightarrow -3^-} \sqrt{9-x^2}$ doesn't exist.

Example 25 Evaluate

a $\lim_{x \rightarrow 2^-} \frac{3x-1}{x-2}$

b $\lim_{x \rightarrow -2^+} \frac{4x-3}{x+2}$

Solution Let us investigate these limits graphically.

Let $f(x) = \frac{3x-1}{x-2}$ and $g(x) = \frac{4x-3}{x+2}$.

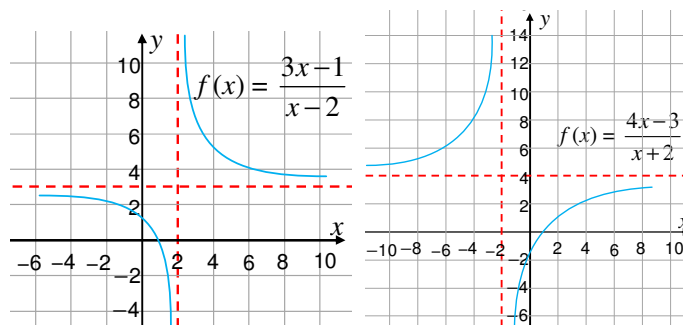

a $\lim_{x \rightarrow 2^-} f(x) = -\infty$

b $\lim_{x \rightarrow -2^+} g(x) = -\infty$

Figure 2.22

ACTIVITY 2.8



- 1** Use the above graphs to evaluate each of the following limits.
- i** $\lim_{x \rightarrow 2^+} f(x)$ **ii** $\lim_{x \rightarrow -2^-} g(x)$ **iii** $\lim_{x \rightarrow \infty} f(x)$ **iv** $\lim_{x \rightarrow -\infty} g(x)$
- 2** Discuss the existence of the limit of a function f at $x = a$, if
- i** $\lim_{x \rightarrow a^+} f(x) = \lim_{x \rightarrow a^-} f(x)$ **ii** $\lim_{x \rightarrow a^+} f(x) \neq \lim_{x \rightarrow a^-} f(x)$
- What can you say about $\lim_{x \rightarrow a^+} f(x)$ and $\lim_{x \rightarrow a^-} f(x)$, if $\lim_{x \rightarrow a} f(x) = L$?

Two side limits

Definition 2.9

Let f be a function defined on an open interval about a , except possibly at a itself. Then, $\lim_{x \rightarrow a} f(x)$ exists, if both $\lim_{x \rightarrow a^+} f(x)$ and $\lim_{x \rightarrow a^-} f(x)$ exist and are equal: That is,

$\lim_{x \rightarrow a} f(x)$ exists, if $\lim_{x \rightarrow a^+} f(x) = \lim_{x \rightarrow a^-} f(x)$.

In this case, $\lim_{x \rightarrow a} f(x) = \lim_{x \rightarrow a^+} f(x) = \lim_{x \rightarrow a^-} f(x)$.

Infinite limits

Example 26 Evaluate each of the following limits.

a $\lim_{x \rightarrow 2^-} \frac{1}{4-x^2}$ **b** $\lim_{x \rightarrow 2^+} \frac{1}{4-x^2}$ **c** $\lim_{x \rightarrow -2^+} \frac{1}{4-x^2}$ **d** $\lim_{x \rightarrow -2^-} \frac{1}{4-x^2}$

Solution Sketch the graph of $f(x) = \frac{1}{4-x^2}$ in order to determine each limit at the same time.

If you try to substitute $x = 2$, the denominator equals 0.

a $\lim_{x \rightarrow 2^-} \frac{1}{4-x^2} = \infty$. The graph is going up indefinitely to ∞ .

b $\lim_{x \rightarrow 2^+} \frac{1}{4-x^2} = -\infty$. The graph is going indefinitely down to $-\infty$.

c $\lim_{x \rightarrow -2^+} \frac{1}{4-x^2} = \infty$ **d** $\lim_{x \rightarrow -2^-} \frac{1}{4-x^2} = -\infty$

Recall that the lines $x = 2$ and $x = -2$ are vertical asymptotes of the rational

function $f(x) = \frac{1}{4-x^2}$.

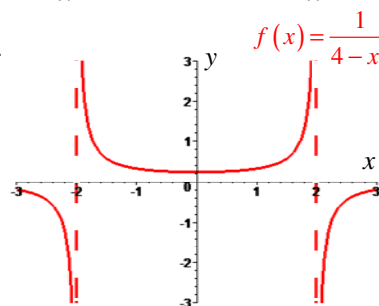
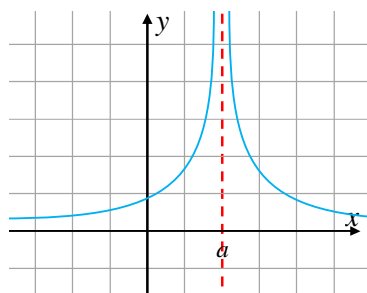

Figure 2.23

Vertical asymptotes

The vertical line $x = a$ is a vertical asymptote to the graph of $y = f(x)$, if one of the following is true.

- 1 $\lim_{x \rightarrow a^-} f(x) = \infty$ 2 $\lim_{x \rightarrow a^+} f(x) = \infty$ 3 $\lim_{x \rightarrow a^-} f(x) = -\infty$ 4 $\lim_{x \rightarrow a^+} f(x) = -\infty$



a $\lim_{x \rightarrow a} f(x) = \infty$

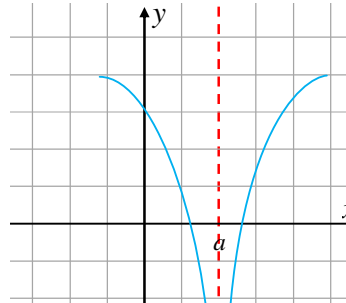

b $\lim_{x \rightarrow a} f(x) = -\infty$

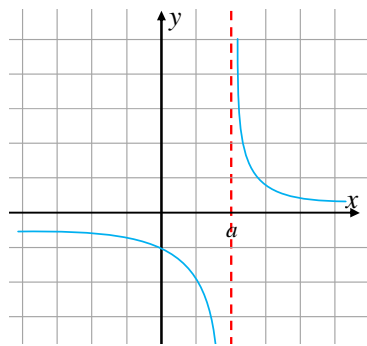

c $\lim_{x \rightarrow a^+} f(x) = \infty$; $\lim_{x \rightarrow a^-} f(x) = -\infty$

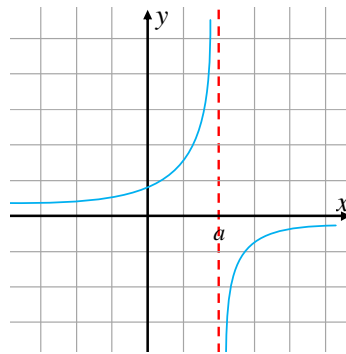

d $\lim_{x \rightarrow a^+} f(x) = -\infty$; $\lim_{x \rightarrow a^-} f(x) = \infty$

Figure 2.24

Exercise 2.7

- 1 The following table displays the amount of wheat produced in quintals per hectare.

year	1995	1996	1997	1998	1999	2000	2001
Qutinal	33	43.6	49.5	53	55.8	57.5	59

Based on this data, the organization that produces the wheat projects that the yearly product at the x^{th} year (taking 1995 as the first year) will be $p(x) = \frac{140x + 25}{2x + 3}$ quintals. Approximate the yearly product after a long period of time.

- 2** Suppose the unemployment rate of a certain country x -years from now is modelled by $u(x) = \frac{45x+35}{9x+2}$ percent. Find the level it will reach as time goes on. Based on the formula, discuss whether the unemployment rate increases or decreases.

- 3** Evaluate each of the following one-side limits.

a $\lim_{x \rightarrow 1^+} \sqrt{x-1}$

b $\lim_{x \rightarrow 1^-} \sqrt{x-1}$

c $\lim_{x \rightarrow 1^+} \sqrt{1-x^2}$

d $\lim_{x \rightarrow -1^-} \sqrt{1-x^2}$

e $\lim_{x \rightarrow -3^-} \sqrt{9-x^2}$

f $\lim_{x \rightarrow -3^+} \sqrt{9-x^2}$

g $\lim_{x \rightarrow 5^+} \frac{1}{x-5}$

h $\lim_{x \rightarrow 5^-} \frac{1}{x-5}$

i $\lim_{x \rightarrow 0^+} \frac{1}{x^2}$

j $\lim_{x \rightarrow 0} \frac{1}{x^2}$

k $\lim_{x \rightarrow 0^+} \frac{4x+|x|}{4x-|x|}$

l $\lim_{x \rightarrow 5^+} \sqrt{4-\sqrt{x^2-9}}$

- 4** Use the following graph of a function f to determine the limits below.

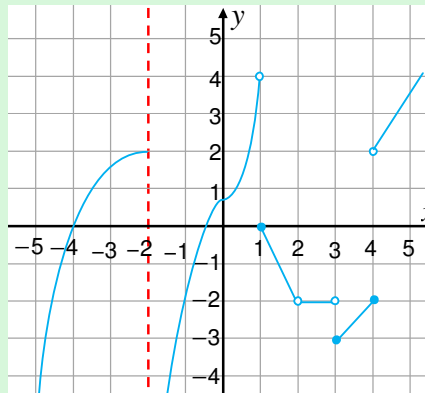

Figure 2.25

a $\lim_{x \rightarrow -3^+} f(x)$

b $\lim_{x \rightarrow -2^-} f(x)$

c $\lim_{x \rightarrow -2^+} f(x)$

d $\lim_{x \rightarrow 1^-} f(x)$

e $\lim_{x \rightarrow 1^+} f(x)$

f $\lim_{x \rightarrow 2} f(x)$

g $\lim_{x \rightarrow 3^+} g(x)$

h $\lim_{x \rightarrow 3^-} f(x)$

i $\lim_{x \rightarrow 4^+} f(x)$

- 5** Let $f(x) = \begin{cases} e^x, & \text{if } x \leq 2 \\ (e-1)x+3, & \text{if } x > 2 \end{cases}$; $g(x) = \begin{cases} x^2 - x, & \text{if } |x| \leq 1 \\ \frac{1}{x}, & \text{if } |x| > 1 \end{cases}$

Evaluate each of the following one side limits.

a $\lim_{x \rightarrow 2^+} (f(x) + g(x))$

b $\lim_{x \rightarrow 2^-} (f(x) - g(x))$

c $\lim_{x \rightarrow 1^+} f(x) g(x)$

d $\lim_{x \rightarrow -1^+} \frac{f(x) - g(x)}{f(x)g(x)}$

6 In each of the following functions, determine whether the graph has a hole or a vertical asymptote at the given point. Determine the one side limits at the given points.

a $f(x) = \frac{x}{x+5}; x = -5$

b $f(x) = \frac{x^3+1}{x+1}; x = -1$

c $f(x) = \frac{|x^2-1|}{x-1}, x = 1$

d $f(x) = \frac{(x-3)^3}{|x-3|}; x = 3$

e $f(x) = \frac{1+\frac{1}{x}}{1-\frac{1}{x}}; x = 0$

f $f(x) = \frac{x}{\sin x}; x = \pi$

2.3 CONTINUITY OF A FUNCTION

The term continuous has the same meaning as it does in our everyday activity. For example, look at the following topographic map between two places *A* and *B* on the graph. The *y*-axis represents how high, in metres, above sea level each point is and the *x*-axis represents distance in kilometres, between points.

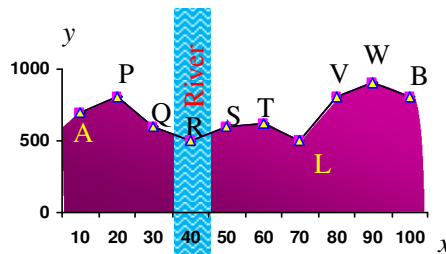

Figure 2.26

This curve is drawn from *A* to *B* without lifting the pencil from the paper. The graph is useful for finding the height above sea level of every point between *A* and *B*.

Think of continuity as drawing a curve without taking the pencil off of the paper.

2.3.1 Continuity of a Function at a Point

ACTIVITY 2.9

Look at the following graphs.

From each graph evaluate $\lim_{x \rightarrow x_0} f(x)$ and $f(x_0)$ and decide whether those values are equal or unequal. Determine whether or not each graph has a hole, jump, or gap at $x = x_0$.



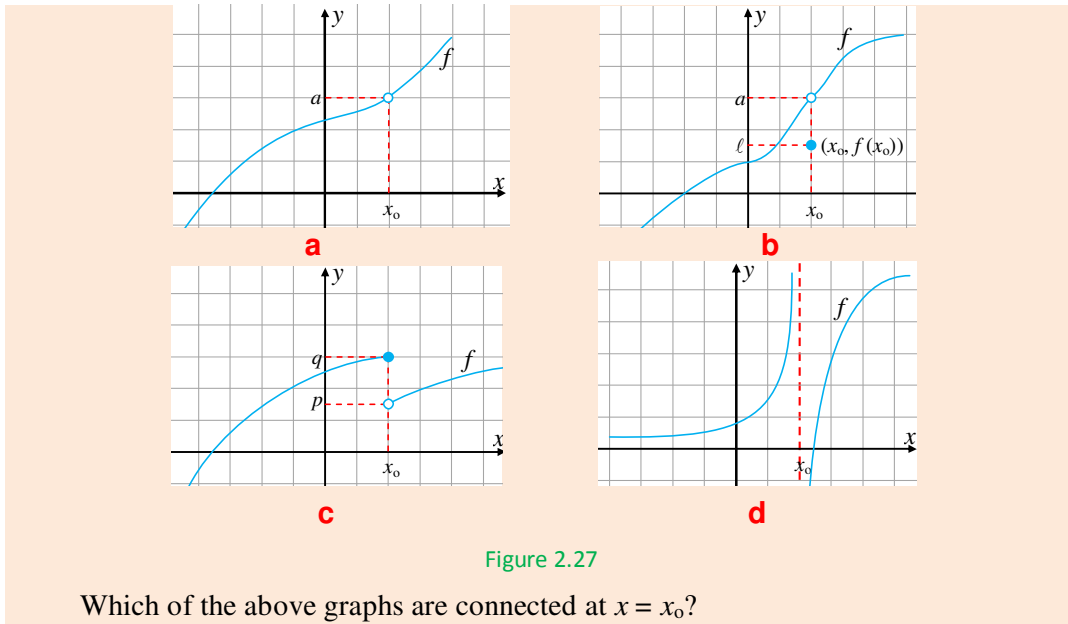

Figure 2.27

Definition 2.10
Continuous function at a point

A function f is said to be continuous at x_0 , if

- i $x_0 \in D_f$ (domain of f)
- ii $\lim_{x \rightarrow x_0} f(x)$ exists and
- iii $\lim_{x \rightarrow x_0} f(x) = f(x_0)$

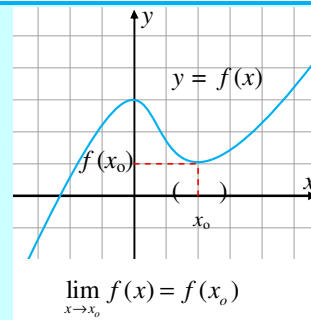

Figure 2.28

Notice that the graph has no interruption at x_0 .

If any of these three conditions is not satisfied, then the function is not continuous at $x = x_0$.

Definition 2.11

A function f is said to be **discontinuous at x_0** , if f is defined on an **open interval** containing x_0 (except possibly at x_0) and f is not continuous at x_0 .

Example 1 Let $f(x) = \frac{|x|}{x}$. Is f continuous at $x = -3$, $x = 0$ and $x = 1$?

Solution $f(x) = \frac{|x|}{x} \Rightarrow f(x) = \begin{cases} 1, & \text{if } x > 0 \\ -1, & \text{if } x < 0 \\ \text{A}, & \text{if } x = 0 \end{cases}$

What is the domain of f ? What is $\lim_{x \rightarrow 0} f(x)$?

The function is not continuous at $x = 0$.

$$\lim_{x \rightarrow 1} f(x) = f(1) \text{ and } \lim_{x \rightarrow -3} f(x) = f(-3)$$

$\Rightarrow f$ is continuous at $x = 1$ and $x = -3$.

Suppose $c \neq 0$, then what is $\lim_{x \rightarrow c} f(x)$?

What is the value of $f(c)$?

Is f continuous at $x = c$?

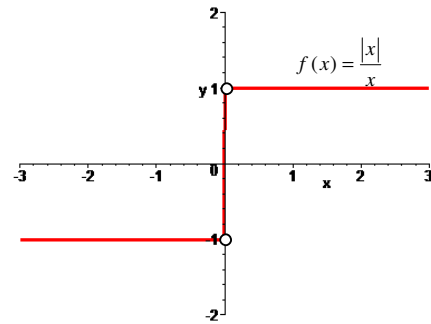

Figure 2.29

Example 2 Let $f(x) = \frac{x^2}{|x|}$. Is f continuous at $x = 0$?

Solution

$$\frac{x^2}{|x|} = \begin{cases} x, & \text{if } x > 0 \\ \cancel{x}, & \text{if } x = 0 \\ -x, & \text{if } x < 0 \end{cases}$$

$f(0)$ is undefined. But $\lim_{x \rightarrow 0} f(x) = 0$.

$\Rightarrow f$ is not continuous at $x = 0$

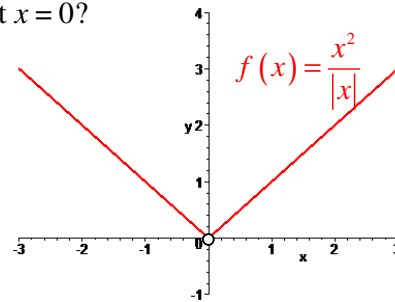

Figure 2.30

Example 3 Find out the condition that makes $f(x) = \frac{1}{x-3}$ discontinuous at $x = 3$?

Solution f is discontinuous at $x = 3$ because

i $f(3)$ is undefined

ii $\lim_{x \rightarrow 3^+} f(x) = \infty$

$$\lim_{x \rightarrow 3^-} f(x) = -\infty$$

$\Rightarrow \lim_{x \rightarrow 3} f(x)$ doesn't exist.

Note that f is unbroken on the interval $(3, \infty)$ and on $(-\infty, 3)$.

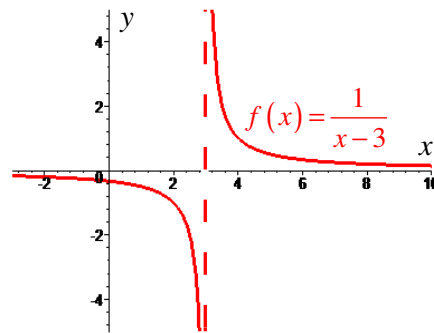

Figure 2.31

Example 4 Consider the piecewise defined function $f(x) = \begin{cases} 0, & \text{if } x \in \mathbb{Z} \\ 1, & \text{if } x \notin \mathbb{Z} \end{cases}$

Is f continuous at $x = 1$? $x = \frac{1}{2}$?

Determine the set of numbers at which f is discontinuous.

Solution

a $\lim_{x \rightarrow 1} f(x) = 1$ and $f(1) = 0$
 $\Rightarrow f$ is discontinuous at $x = 1$

b $\lim_{x \rightarrow \frac{1}{2}} f(x) = 1$ and $f\left(\frac{1}{2}\right) = 1$
 $\Rightarrow f$ is continuous at $x = \frac{1}{2}$.

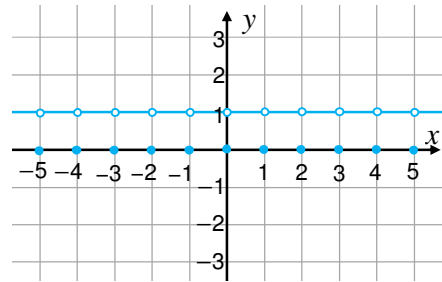

Figure 2.32

Use the graph in Figure 2.32 to evaluate $\lim_{x \rightarrow c} f(x)$ when c is an integer.

Do you see that f is discontinuous at every integer? Justify!

Example 5 Show that $f(x) = \frac{\sqrt{x^2 - 3x + 2}}{x - 5}$ is continuous at $x = 3$.

Solution What is the domain of f ? Is 3 in the domain of f ?

$$f(3) = \frac{\sqrt{3^2 - 3(3) + 2}}{3 - 5} \Rightarrow f(3) = -\frac{\sqrt{2}}{2}.$$

$$\text{Also, } \lim_{x \rightarrow 3} \frac{\sqrt{x^2 - 3x + 2}}{x - 5} = -\frac{\sqrt{2}}{2}$$

$\Rightarrow f$ is continuous at $x = 3$.

2.3.2 Continuity of a function on an Interval

Consider the following graph of a function f .

Determine those intervals on which the graph is drawn without taking the pencil off the paper.

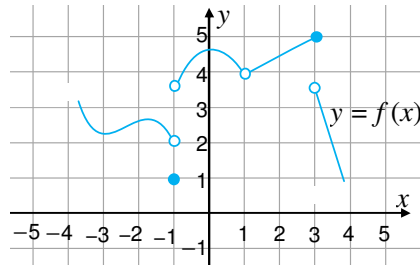

Figure 2.33

The function is discontinuous at $x = -1$, $x = 1$ and $x = 3$.

The graph is continuously drawn on the intervals.

$$(-\infty, -1), (-1, 1), (1, 3] \text{ and } (3, \infty)$$

Definition 2.12

(One side continuity)

A function f is continuous from the right at $x = a$ provided that

$$\lim_{x \rightarrow a^+} f(x) = f(a).$$

A function f is continuous from the left at $x = b$ provided that

$$\lim_{x \rightarrow b^-} f(x) = f(b).$$

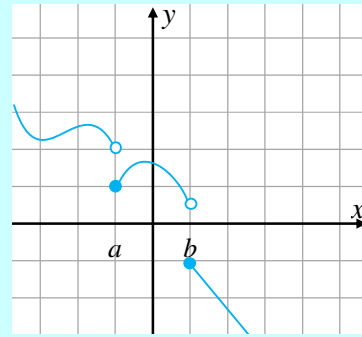

Figure 2.34

Example 6 Let $f(x) = \sqrt{1-x^2}$; show that f is continuous from the right at $x = -1$ and continuous from the left at $x = 1$.

Solution

a $\lim_{x \rightarrow -1^+} \sqrt{1-x^2} = 0$ and $f(-1) = 0$

b $\lim_{x \rightarrow 1^-} \sqrt{1-x^2} = 0$ and $f(1) = 0$

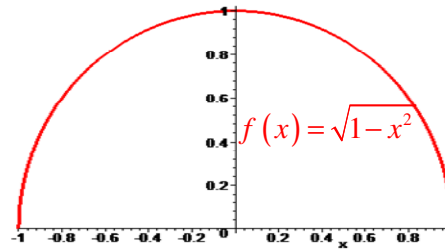

Figure 2.35

The graph of f , shown in Figure 2.35, also illustrates the answers.

Example 7 Show that $g(x) = \sqrt{1-3x}$ is continuous from the left at $x = \frac{1}{3}$.

Solution From the graph one can see that $\lim_{x \rightarrow \frac{1}{3}^-} g(x) = 0 = g\left(\frac{1}{3}\right)$

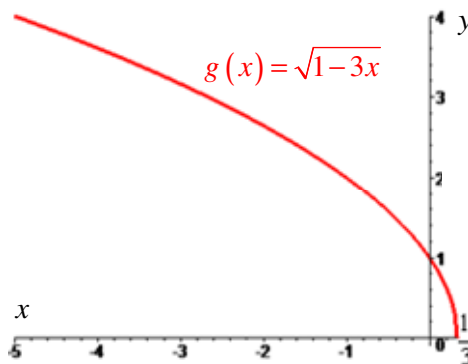

Figure 2.36

Example 8 Let $f(x) = \frac{x^2 - 9}{|x - 3|}$. Show that f is continuous neither from the right nor from the left at $x = 3$

Solution The basic strategy to solve such a problem is to sketch the graph.

$$\frac{x^2 - 9}{|x - 3|} \begin{cases} = x + 3, & \text{if } x > 3 \\ \text{is not defined,} & \text{if } x = 3 \\ = -x - 3, & \text{if } x < 3 \end{cases}$$

$$\lim_{x \rightarrow 3^-} f(x) = \lim_{x \rightarrow 3^-} (-x - 3) = -6$$

But $f(3)$ is undefined

$\Rightarrow f$ is not continuous from the left at $x = 3$

Similarly, f is discontinuous from the right at $x = 3$.

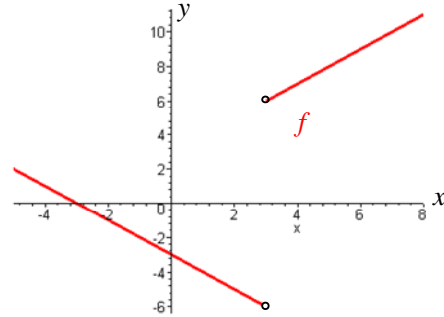

Figure 2.37

We know that the polynomials $x + 3$ and $-x - 3$ are continuous on the entire intervals $(3, \infty)$ and $(-\infty, 3)$, respectively.

Definition 2.13

Continuity of a function on an interval.

1 Open interval

A function f is continuous on an open interval (a, b) , if

$$\lim_{x \rightarrow c} f(x) = f(c) \quad \forall c \in (a, b).$$

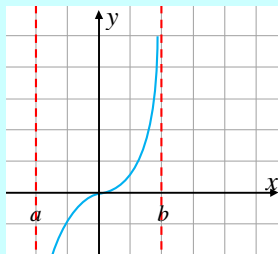

a

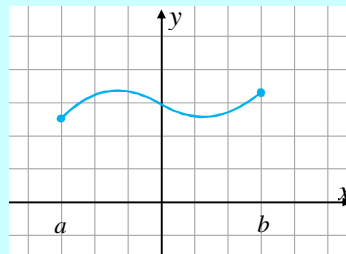

b

Figure 2.38

2 Closed interval

A function f is continuous on the closed interval $[a, b]$ provided that

- i f is continuous on (a, b)
- ii f is continuous from the right at a , and
- iii f is continuous from the left at b .

A function f is continuous, if it is continuous over its domain.

Some continuous functions

- ✓ Polynomial functions
- ✓ Absolute value of continuous functions
- ✓ The sine and cosine functions
- ✓ Exponential functions
- ✓ Logarithmic functions

Example 9 The following is the graph of a function f . Determine the intervals on which f is continuous.

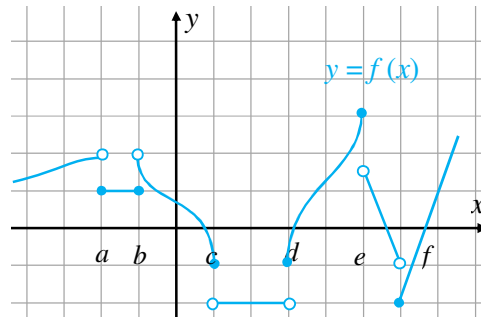

Figure 2.39

Solution It is continuous on $(-\infty, a)$, $[a, b]$, $(b, c]$, (c, d) , $[d, e]$, (e, f) , $[f, \infty)$.

Example 10 Determine whether or not each of the following functions are continuous on the given interval:

- a** $f(x) = \frac{1}{x}, (0, 5)$ **b** $f(x) = \frac{x^2 - 4}{x + 2}, (-3, 3)$
- c** $f(x) = 2x^3 - 5x^2 + 7x + 11, (-\infty, \infty)$.

Solution

- a** f is a rational function and $x \neq 0$ for each $x \in (0, 5)$. Hence, we conclude that f is continuous on $(0, 5)$.
- b** f is undefined at $x = -2$. Hence, f is discontinuous at $x = -2$ but f is continuous at any other point on $(-3, 3)$. Thus f is not continuous on $(-3, 3)$.
- c** Every polynomial function is continuous on $(-\infty, \infty)$. Thus, f is continuous on $(-\infty, \infty)$.

Example 11 Let $f(x) = \begin{cases} 4 - x^2, & \text{if } x < 1 \\ 5, & \text{if } 1 \leq x < 4 \\ -1, & \text{if } x = 4 \\ x + 1, & \text{if } x > 4 \end{cases}$

Determine the intervals on which f is continuous.

Solution

From the graph on **Figure 2.40** you may see that f is continuous on $(-\infty, 1)$, $[1, 4)$ and $(4, \infty)$. But it is discontinuous at $x = 1$ and $x = 4$.

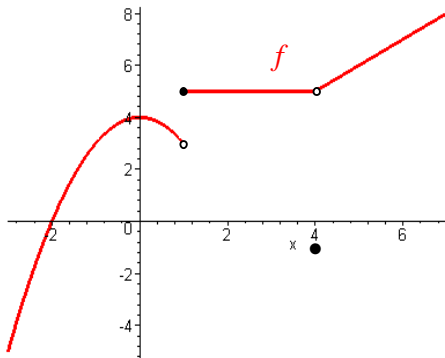

Figure 2.40

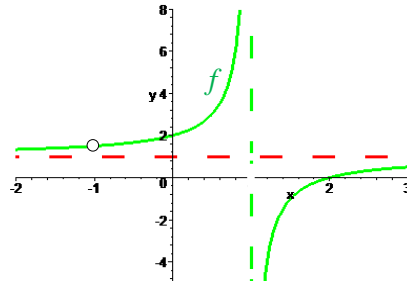

Figure 2.41

Example 12 Let $f(x) = \frac{x^2 - x - 2}{x^2 - 1}$. Find the intervals where f is continuous.

Solution $\frac{x^2 - x - 2}{x^2 - 1} = \frac{(x-2)(x+1)}{(x-1)(x+1)} = \frac{x-2}{x-1}$, if $x \neq -1, 1$

f is discontinuous at $x = -1$ and $x = 1$.

f is continuous on $(-\infty, -1)$, $(-1, 1)$ and $(1, \infty)$ as it is shown in **Figure 2.41**.

Example 13 Let $f(x) = \begin{cases} 2^{-x}, & \text{if } x < -1 \\ 2x+2, & \text{if } -1 \leq x < 3 \\ 4-x, & \text{if } x \geq 3 \end{cases}$

Determine the intervals on which f is continuous.

Solution Look at the graph of f .

Are -1 and 3 in the domain of f ?

f is continuous on $(-\infty, -1)$, $[-1, 3)$, $[3, \infty)$

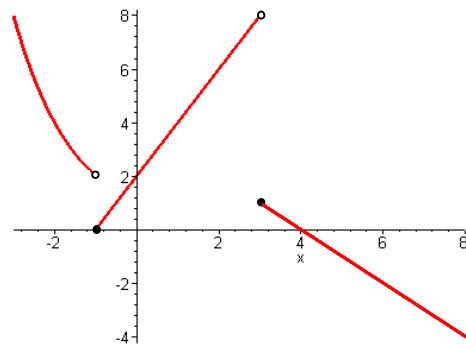

Figure 2.42

Example 14 Determine the interval on which $f(x) = \sqrt{x^2 - 1}$ is continuous.

Solution In $f(x) = \sqrt{x^2 - 1}$, $x^2 - 1 \geq 0 \Rightarrow |x| \geq 1$

The domain of f is $\{x : |x| \geq 1\}$

Explain why f is discontinuous on $(-1, 1)$!

f is continuous on $(-\infty, -1] \cup [1, \infty)$. (*Explain!*)

Example 15 Let $f(x) = \frac{1}{\sqrt{9-4x^2}}$. What is

the largest interval on which f is continuous?

Solution First determine the domain and sketch the graph of f .

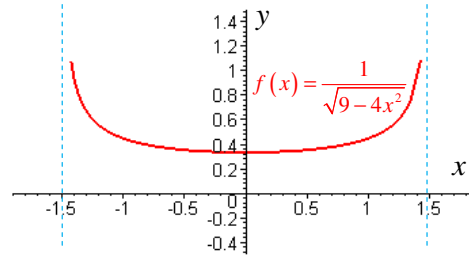

Figure 2.43

Explain why f is continuous on $\left(-\frac{3}{2}, \frac{3}{2}\right)$.

Is there an interval larger than $\left(-\frac{3}{2}, \frac{3}{2}\right)$ on which f is continuous?

Example 16 Determine the value of a so that the piecewise defined function

$$f(x) = \begin{cases} x+3, & \text{if } x > 2 \\ ax-1, & \text{if } x \leq 2 \end{cases} \text{ is continuous on } (-\infty, \infty).$$

Solution If f is continuous on $(-\infty, \infty)$, then f must be continuous at $x = 2$.

$$\Rightarrow \lim_{x \rightarrow 2^+} f(x) = f(2) \Rightarrow \lim_{x \rightarrow 2^+} (x+3) = a(2) - 1 \Rightarrow 5 = 2a - 1 \Rightarrow a = 3$$

$$\Rightarrow f(x) = \begin{cases} x+3, & \text{if } x > 2 \\ 3x-1, & \text{if } x \leq 2 \end{cases}$$

Example 17 Let $f(x) = \begin{cases} ax+b, & \text{if } x \leq -2 \\ 2x+a, & \text{if } -2 < x \leq 3 \\ ax^2 - bx + 4, & \text{if } x > 3 \end{cases}$

If f is a continuous function, find the values of a and b .

Solution f should be continuous at $x = -2$ and $x = 3$ because f is a continuous function.

i f is continuous at $x = -2$

$$\Rightarrow \lim_{x \rightarrow -2^+} f(x) = f(-2) \Rightarrow \lim_{x \rightarrow -2^+} (2 \times (-2) + a) = (a(-2) + b) \Rightarrow -4 + a = -2a + b$$

$$\Rightarrow 3a - b = 4 \dots \dots \dots \text{equation (1)}$$

ii f is continuous at $x = 3$

$$\Rightarrow \lim_{x \rightarrow 3^+} f(x) = f(3) \Rightarrow \lim_{x \rightarrow 3^+} (ax^2 - bx + 4) = 2(3) + a$$

$$\Rightarrow 9a - 3b + 4 = 6 + a$$

$$\Rightarrow 8a - 3b = 2 \dots \dots \dots \text{equation (2)}$$

Solving the system of equations

$$\begin{cases} 3a - b = 4 \\ 8a - 3b = 2 \end{cases} \text{ gives } a = 10 \text{ and } b = 26.$$

Example 18 Discuss the continuity of the function $f(x) = \sqrt{3 - \sqrt{x^2 - 16}}$

Solution In $\sqrt{x^2 - 16}, x^2 - 16 \geq 0 \Rightarrow x^2 \geq 16 \Rightarrow |x| \geq 4$

$$\text{In, } \sqrt{3 - \sqrt{x^2 - 16}}, 3 - \sqrt{x^2 - 16} \geq 0 \Rightarrow 3 \geq \sqrt{x^2 - 16} \Rightarrow 25 \geq x^2 \Rightarrow |x| \leq 5.$$

Thus, $|x| \geq 4$ and $|x| \leq 5$

$\Rightarrow f$ is continuous on $[-5, -4]$ and $[4, 5]$.

Example 19 A library that rents books allows its customers to keep a book up to 5 days at a fee of Birr 10. Customers who keep a book more than 5 days pay Birr 2 penalty plus Birr 1.25 per day for being late beyond the first 5 days. If $c(x)$ represents the cost of keeping a book for x days, discuss the continuity of c on $[0, 20]$.

Solution We first determine a formula for $c(x)$. From the given information, the fee for the first 5 days is Birr 10.

$$\Rightarrow c(x) = 10, \text{ if } 0 < x \leq 5.$$

For $x > 5$, $c(x) = 10 + 2 + (x - 5)(1.25)$. *Explain!*

$$= 1.25x + 5.75$$

$$\Rightarrow c(x) = \begin{cases} 10, & \text{if } 0 < x \leq 5 \\ 1.25x + 5.75, & \text{if } x > 5 \end{cases}$$

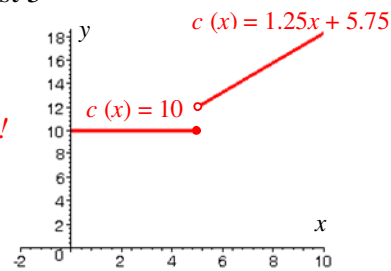

Figure 2.44

The constant 10, and the polynomial $1.25x + 5.75$ are continuous on $(0, 5]$ and $(5, 20]$ respectively. Thus, c is continuous on $(0, 5]$ and $(5, 20]$.

$$\text{But } \lim_{x \rightarrow 5^+} c(x) = 1.25(5) + 5.75 = 12$$

$$\lim_{x \rightarrow 5^-} c(x) = 10 \Rightarrow \lim_{x \rightarrow 5} c(x) \text{ doesn't exist } \Rightarrow c \text{ is not continuous at } x = 5$$

Properties of continuous functions

Suppose f and g are continuous at $x = x_0$, discuss the continuity of the combinations of f and g .

Is $f + g$ continuous at $x = x_0$?

$$\begin{aligned} \lim_{x \rightarrow x_0} (f + g)(x) &= \lim_{x \rightarrow x_0} (f(x) + g(x)) = \lim_{x \rightarrow x_0} f(x) + \lim_{x \rightarrow x_0} g(x). \text{ Why?} \\ &= f(x_0) + g(x_0) = (f + g)(x_0) \end{aligned}$$

Hence, $f + g$ is continuous at $x = x_0$.

Explain that the continuity of the combinations of f and g is an immediate consequence of the **basic limit theorems**.

Theorem 2.3 Properties of continuous functions

If f and g are continuous at $x = x_0$, then the following functions are continuous at $x = x_0$.

- | | | |
|------------------|--|---------------------------------|
| 1 $f + g$ | 2 $f - g$ | 3 $kg, k \in \mathbb{R}$ |
| 4 fg | 5 $\frac{f}{g}$, provided that $g(x_0) \neq 0$. | |

Example 20 Let $f(x) = x, g(x) = \sin x$. Discuss the continuity of the combinations of f and g at $x = 0$.

Solution f and g are continuous at $x = 0$. Hence, $f + g, f - g, kf$ and fg are continuous at $x = 0$. $\lim_{x \rightarrow 0} \frac{f(x)}{g(x)} = \lim_{x \rightarrow 0} \frac{x}{\sin x} = 1$

But, $\frac{f}{g}(0)$ is undefined. Hence, $\frac{f}{g}$ is not continuous at $x = 0$.

Example 21 Discuss the continuity of the function given by

$$f(x) = \begin{cases} 4 - \sqrt{9 - x^2}, & \text{if } |x| \leq 3 \\ 10 - 2x, & \text{if } x > 3 \end{cases}$$

Solution Can you determine the range of values of $\sqrt{9 - x^2}$? What is the curve represented by

$$y = 4 - \sqrt{9 - x^2}?$$

Do you see that

$$1 \leq 4 - \sqrt{9 - x^2} \leq 4?$$

The function is continuous on

$[-3, \infty)$ as it is shown in the figure.

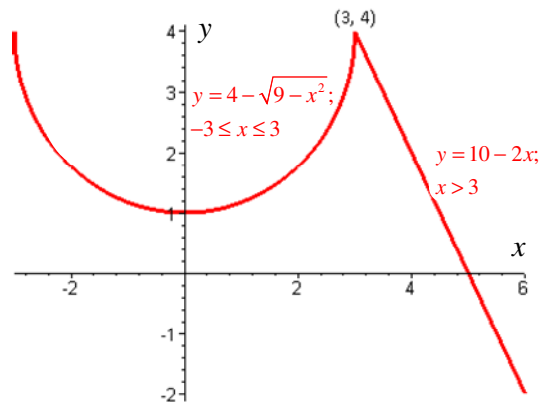

Figure 2.45

Some of the above examples are the compositions of two or more simple functions.

In general, you have the following theorem on the continuity of the compositions of functions.

Theorem 2.4 Continuity of compositions of functions

If a function f is continuous at $x = x_0$ and the function g is continuous at $y = f(x_0)$, then the composition function $g \circ f$ is continuous at $x = x_0$.

$$\text{i.e., } \lim_{x \rightarrow x_0} g(f(x)) = \lim_{y \rightarrow f(x_0)} g(y) = g(f(x_0)) = (g \circ f)(x_0).$$

Example 22 Let $f(x) = x^2 - 3x + 2$ and $g(x) = \sqrt{x}$.

Show that $g \circ f$ is continuous at $x = -1$.

Solution $x_0 = -1$, f is continuous at $x = -1$. *Explain!*

$f(x_0) = f(-1) = 6 \Rightarrow g$ is continuous at $y = 6$.

$$\begin{aligned} \text{In short, } \lim_{x \rightarrow -1} (g \circ f)(x) &= \lim_{x \rightarrow -1} \sqrt{x^2 - 3x + 2} = \sqrt{\lim_{x \rightarrow -1} (x^2 - 3x + 2)} \\ &= \sqrt{6} \end{aligned}$$

Maximum and minimum values

Maximum and minimum are common words in real life usage.

For example, Dalol Danakil Depression in Ethiopia has the maximum average annual temperature in the world which is 35°C .

The minimum average annual temperature in the world is -57.2°C which is in Antarctic. Discuss other minimum and maximum values that exist in real world phenomena.

Maximum and minimum values of a continuous function on a closed interval

Example 23 Find the maximum and minimum values on the closed interval.

a $f(x) = 3x - 1$ on $[-2, 3]$.

b $f(x) = -x^2 + 3x - 4$ on $[1, 5]$

Solution

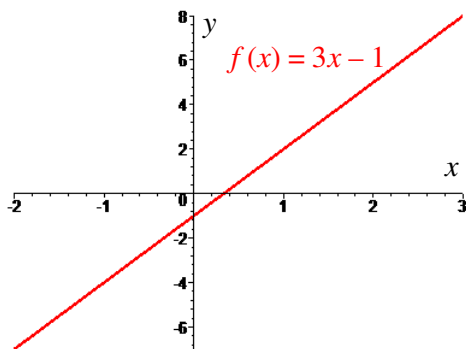

Figure 2.46

$$-7 \leq f(x) \leq 8 \quad \forall x \in [-2, 3]$$

The maximum value is 8.

The minimum value is -7

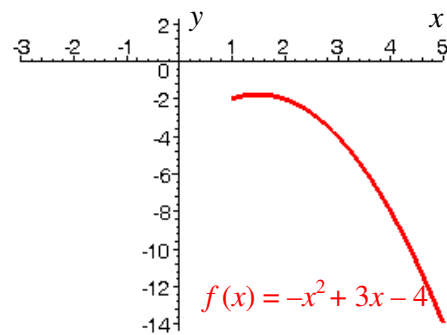

Figure 2.47

$$-14 \leq f(x) \leq -\frac{7}{4} \quad \forall x \in [1, 5]$$

The maximum value is $-1\frac{3}{4}$

The minimum value is -14 .

The intermediate value theorem

Theorem 2.5 The intermediate value theorem

Suppose f is a continuous function on the closed interval $[a, b]$ and k is any real number with either $f(a) \leq k \leq f(b)$ or $f(b) \leq k \leq f(a)$, then there exists c in $[a, b]$ such that $f(c) = k$.

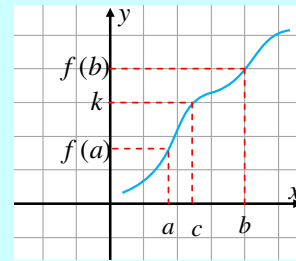

Figure 2.48

Example 24 Show that $f(x) = x^3 + x + 1$ has a zero between $x = -1$ and $x = 0$.

Solution Using the **intermediate value theorem**, $k = 0$, $a = -1$, $b = 0$,

$$f(-1) = (-1)^3 - 1 + 1 = -1 < 0.$$

$$f(0) = 0 + 0 + 1 = 1 \Rightarrow f(-1) < 0 < f(0)$$

$$\Rightarrow \exists c \in [-1, 0] \text{ such that } f(c) = 0.$$

Example 25 Show that the graph of $g(x) = x^5 - 2x^3 + x - 7$ crosses the line $y = 7.3$

Solution $f(1) = 1 - 2 + 1 - 7 = -7$

$$f(2) = 32 - 16 + 2 - 7 = 11$$

$$\Rightarrow f(1) < 7.3 < f(2)$$

\Rightarrow The graph crosses the line $y = 7.3$

Example 26 Use the **intermediate value theorem** to locate the zeros of the function

$$f(x) = x^4 - x^3 - 5x^2 + 2x + 1.$$

Solution Every polynomial function is continuous.

$$f(0) = 1 > 0$$

$$f(1) = 1 - 1 - 5 + 2 + 1 = -2 < 0$$

$\Rightarrow f$ has a zero between $x = 0$ and $x = 1$.

$$f(2) = 16 - 8 - 20 + 4 + 1 = -7 < 0 \text{ and}$$

$$f(3) = 81 - 27 - 45 + 6 + 1 = 16 > 0$$

$\Rightarrow f$ has a zero between $x = 2$ and $x = 3$

$$f(-1) = 1 + 1 - 5 - 2 + 1 = -4 < 0$$

$\Rightarrow f$ has a zero between $x = 0$ and $x = -1$

$$f(-2) = 16 + 8 - 20 - 4 + 1 = 1 > 0$$

$\Rightarrow f$ has a zero between $x = -1$ and $x = -2$

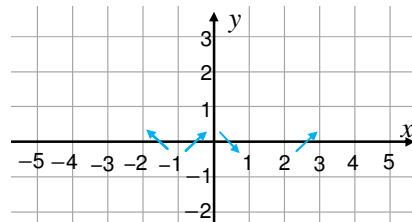

Figure 2.49

Note:

- ✓ Discontinuous functions may not possess the intermediate value property. To see this, consider $f(x) = \frac{1}{x}$ which is discontinuous at 0. $f(-1) < 0$ and $f(1) > 0$ but there is no value of x in $(-1, 1)$ such that $f(x) = 0$

Approximating real zeros by bisection

Let f be a continuous function on the closed interval $[a, b]$. If $f(a)$ and $f(b)$ are opposite in sign, then by the **intermediate value theorem** f has a zero in (a, b) . In order to get an interval $I \subset (a, b)$, in which f has zero, bisect the interval $[a, b]$ by the midpoint $c = \frac{a+b}{2}$.

If $f(c) = 0$, stop searching a zero. If $f(c) \neq 0$, then choose the interval (a, c) or (c, b) in which $f(c)$ has an opposite sign at the end point.

Repeat this bisection process until you get the desired decimal accuracy for the approximation.

Example 27 Approximate the real root of $f(x) = x^3 + x - 1$ with an error less than $\frac{1}{16}$.

Solution Using a calculator, you can fill in the following table and get a number as required.

Opposite sign interval (a, b)	Mid-point c	Sign of f		
		$f(a)$	$f(c)$	$f(b)$
$(0, 1)$	0.5	-	-	+
$(0.5, 1)$	0.75	-	+	+
$(0.5, 0.75)$	0.625	-	-	+
$(0.625, 0.75)$	0.6875	-	+	+

$$f(0.6875) = 0.012451172 < 0.0625 = \frac{1}{16}$$

$$\Rightarrow 0.6875 \text{ is a root of } f \text{ with an error less than } \frac{1}{16}$$

Example 28 Use the bisection method to find an approximation of $\sqrt[3]{7}$ with an error less than $\frac{1}{20}$.

Solution Let $x = \sqrt[3]{7}$, then $x^3 = 7 \Rightarrow x^3 - 7 = 0$. Define a function f by $f(x) = x^3 - 7$, $f(1) = -6 < 0$ and $f(2) = 1 > 0$
 $\Rightarrow f$ has a real root in $(1, 2)$.

Look at the following table.

Opposite sign interval (a, b)	Mid-point c	Sing of f		
		f(a)	f(c)	f(b)
(1, 2)	1.5	-	-	+
(1.5, 2)	1.75	-	-	+
(1.75, 2)	1.875	-	-	+
(1.875, 2)	1.9375	-	+	+
(1.875, 1.9375)	1.90625	-	-	+
(1.90625, 1.9375)	1.921875	-	+	+
(1.90625, 1.921875)	1.9140625	-	+	+

$$f(1.9140625) = 0.01242685 < 0.05 = \frac{1}{20}$$

$$\Rightarrow \sqrt[3]{7} \approx 1.9140625 \text{ with an error less than } \frac{1}{20}$$

Theorem 2.6 Extreme value theorem

Let f be a continuous function on $[a, b]$. Then there are two numbers x_1 and x_2 in $[a, b]$ such that $f(x_1) \leq f(x) \leq f(x_2) \forall x \in [a, b]$.

$f(x_2)$ is the maximum value and $f(x_1)$ is the minimum value.

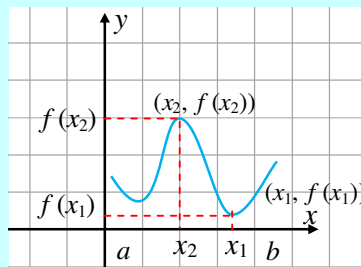

Figure 2.50

Group Work 2.1

1 Discuss the following points by drawing graphs and producing examples.

Are there maximum and minimum values, if

- i the function on $[a, b]$ is not continuous?
- ii the function is continuous on (a, b) ?
- iii the function is not continuous but defined on an open interval?



- 2** Let f be continuous on $[a, b]$. Answer the following points in terms of $f(a)$ and $f(b)$. Use graphs to illustrate your answers.
- i** Find the minimum and the maximum values of $f(x)$ when f is an increasing function.
 - ii** Find the minimum and maximum values of $f(x)$ when f is decreasing.
- 3** Discuss the following statements using the **intermediate value theorem**.
- i** Among all squares whose sides do not exceed 10 cm, is there a square whose area is $11\sqrt{7}\text{cm}^2$, $11\sqrt{17}\text{cm}^2$?
 - ii** Among all circles whose radii are between 10cm and 20 cm, is there a circle whose area is 628 cm^2 ?
 - iii** There was a year when you were half as tall as you are on today.

Exercise 2.8

- 1** Determine whether or not each of the following functions is continuous at the given number.
- a** $f(x) = 3, x = 5$
 - b** $f(x) = 2x^2 - 5x + 3; x = 1$
 - c** $f(x) = \frac{(x-3)^2}{|x-3|}; x = 3$
 - d** $f(x) = \frac{(x-4)}{x^2+1}; x = -1$
 - e** $f(x) = \begin{cases} \sin x, & x > 0 \\ 1, & x = 0 \\ \frac{1}{x}, & x < 0 \end{cases}; x = 0$
 - f** $f(x) = \begin{cases} |x|-1, & \text{if } |x| > 1 \\ 0, & \text{if } x = \pm 1 \\ 1-|x|, & \text{if } |x| < 1 \end{cases}; x = \pm 1$
- 2** If the piecewise defined functions below are continuous, determine the values of the constants.
- a** $f(x) = \begin{cases} ax-3, & \text{if } x > 2 \\ 2x+5, & \text{if } x \leq 2 \end{cases}$
 - b** $f(x) = \begin{cases} ax^2+bx+1, & \text{if } 2 \leq x \leq 3 \\ ax-b, & \text{if } x < 2 \\ bx+4, & \text{if } x > 3 \end{cases}$
 - c** $f(x) = \begin{cases} \sqrt{x^2-2x+a}, & \text{if } \frac{1}{2} \leq x \leq \frac{3}{2} \\ -\sqrt{-x^2+2x-\frac{3}{4}}, & \text{if } x < \frac{1}{2} \text{ or } x > \frac{3}{2} \end{cases}$
 - d** $f(x) = \begin{cases} \frac{k(x-5)}{x^2-25}, & x \neq \pm 5 \\ 5 & \text{if } x = \pm 5 \end{cases}$
 - e** $f(x) = \begin{cases} 2^{|x-4|}, & \text{if } x > 4 \\ 2x, & \text{if } x \leq 4 \end{cases}$

3 Find the maximum possible interval(s) on which these functions are continuous.

a $f(x) = \begin{cases} \frac{x^2 - 4}{x - 2}, & \text{if } x \neq 2 \\ 8, & \text{if } x = 2 \end{cases}$

b $f(x) = e^{-x^2}$

c $f(x) = \begin{cases} 4 \frac{|x^2 - 1|}{x - 1}, & \text{if } x \neq 1 \\ 5, & \text{if } x = 1 \end{cases}$

d $f(x) = \sqrt{1 - 4x^2}$

e $f(x) = \frac{1}{\sqrt{9 - 4x^2}}$

f $f(x) = \begin{cases} \frac{5(x^3 + 1)}{x + 1}, & \text{if } x \neq -1 \\ 10, & \text{if } x = -1 \end{cases}$

g $f(x) = \sqrt{2 - \sqrt{5 - x^2}}$

4 The monthly base salary of a shoes sales person is Birr 900. She has a commission of 2% on all sales over Birr 10,000 during the month. If the monthly sales are Birr 15,000 or more, she receives Birr 500 bonus. If x represents the monthly sales in Birr and $f(x)$ represents income in Birr, express $f(x)$ in terms of x and discuss the continuity of f on $[0, 25000]$.

2.4 EXERCISES ON APPLICATIONS OF LIMITS

ACTIVITY 2.10



1 Let x be a real number. Fill in the table below with appropriate values.

x	0.0001	0.0002	0.0003	0.0004	0.0005	0.0006
$\sin x$						
$\frac{\sin x}{x}$						

2 Use the table to predict $\lim_{x \rightarrow 0} \frac{\sin x}{x}$.

3 Use the following graph of $f(x) = \frac{\sin x}{x}$ to determine $\lim_{x \rightarrow 0} \frac{\sin x}{x}$.

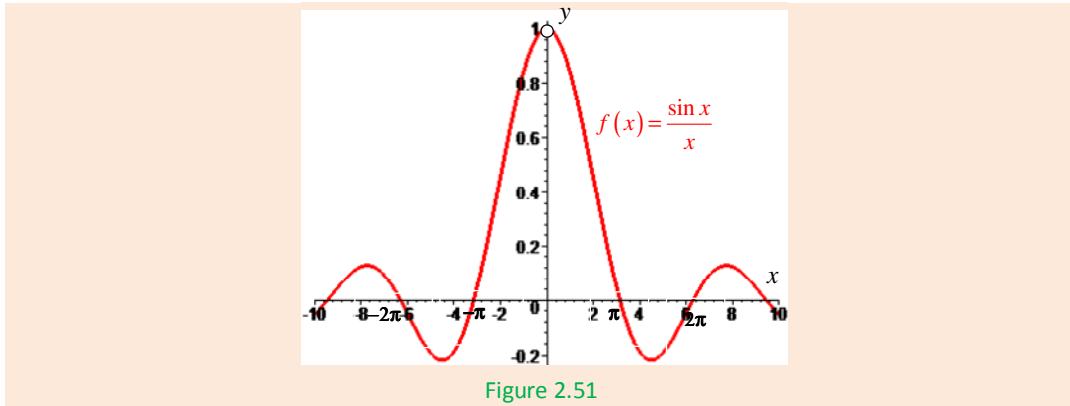
**Theorem 2.7**

$$\lim_{x \rightarrow 0} \frac{\sin x}{x} = 1, \text{ where } x \text{ is in radians.}$$

Example 1 Evaluate each of the following limits.

a $\lim_{x \rightarrow 0} \frac{\sin(3x)}{x}$

b $\lim_{x \rightarrow \infty} x \sin\left(\frac{1}{x}\right)$

c $\lim_{x \rightarrow \infty} x^2 \sin\left(\frac{1}{x^2}\right)$

d $\lim_{x \rightarrow 0} \frac{x}{\sin x}$

e $\lim_{x \rightarrow 0} \frac{\tan x}{\sin x}$

f $\lim_{x \rightarrow 0} \frac{\sin(3x)}{\sin(4x)}$

g $\lim_{x \rightarrow 0} \frac{\sin^3 x}{x^3}$

h $\lim_{x \rightarrow 0} \frac{1 - \cos x}{x^2}$

i $\lim_{x \rightarrow 1} \frac{\sin(x-1)}{1-x+x^2-x^3}$

Solution

a $\lim_{x \rightarrow 0} \frac{\sin(3x)}{x} = \lim_{x \rightarrow 0} \frac{3 \sin(3x)}{(3x)} = 3 \lim_{x \rightarrow 0} \frac{\sin(3x)}{3x} = 3$

b $\lim_{x \rightarrow \infty} x \sin\left(\frac{1}{x}\right) = \lim_{x \rightarrow \infty} \frac{\sin\left(\frac{1}{x}\right)}{\frac{1}{x}} = \lim_{y \rightarrow 0} \left(\frac{\sin y}{y}\right) = 1, \text{ where } y = \frac{1}{x}$

c $\lim_{x \rightarrow \infty} x^2 \sin\left(\frac{1}{x^2}\right) = \lim_{x \rightarrow \infty} \left(\frac{\sin \frac{1}{x^2}}{\frac{1}{x^2}}\right) = \lim_{y \rightarrow 0} \left(\frac{\sin(y)^2}{y^2}\right) = 1. \text{ Why?}$

d $\lim_{x \rightarrow 0} \frac{x}{\sin x} = \lim_{x \rightarrow 0} \left(\frac{1}{\left(\frac{\sin x}{x}\right)}\right) = 1. \text{ Why?}$

$$\text{e} \quad \lim_{x \rightarrow 0} \frac{\tan x}{\sin x} = \lim_{x \rightarrow 0} \frac{\left(\frac{\tan x}{x}\right)}{\left(\frac{\sin x}{x}\right)} = \frac{\lim_{x \rightarrow 0} \frac{\tan x}{x}}{\lim_{x \rightarrow 0} \frac{\sin x}{x}} = \frac{1}{1} = 1. \text{ Why?}$$

$$\text{f} \quad \lim_{x \rightarrow 0} \frac{\sin(3x)}{\sin(4x)} = \lim_{x \rightarrow 0} \frac{\left(\frac{3 \sin(3x)}{3x}\right)}{\left(\frac{4 \sin(4x)}{4x}\right)} = \frac{3}{4}. \text{ Why?}$$

$$\text{g} \quad \lim_{x \rightarrow 0} \frac{\sin^3 x}{x^3} = \left(\lim_{x \rightarrow 0} \frac{\sin x}{x}\right)^3 = 1$$

$$\begin{aligned} \text{h} \quad \lim_{x \rightarrow 0} \frac{1 - \cos x}{x^2} &= \lim_{x \rightarrow 0} \frac{1 - \cos x}{x^2} \cdot \frac{1 + \cos x}{1 + \cos x} = \lim_{x \rightarrow 0} \frac{1 - \cos^2 x}{x^2(1 + \cos x)} \\ &= \lim_{x \rightarrow 0} \left(\frac{\sin x}{x}\right)^2 \cdot \lim_{x \rightarrow 0} \frac{1}{1 + \cos x} = 1 \times \frac{1}{2} = \frac{1}{2} \end{aligned}$$

$$\begin{aligned} \text{i} \quad \lim_{x \rightarrow 1} \frac{\sin(x-1)}{1-x+x^2-x^3} &= \lim_{x \rightarrow 1} \frac{-\sin(1-x)}{(1-x)+x^2(1-x)} = \lim_{x \rightarrow 1} \frac{-\sin(1-x)}{(1-x)(x^2+1)} \\ &= -\lim_{x \rightarrow 1} \frac{\sin(1-x)}{1-x} \cdot \lim_{x \rightarrow 1} \left(\frac{1}{x^2+1}\right) = -\frac{1}{2} \end{aligned}$$

Example 2 The area A of a regular n -sided polygon inscribed in a circle of radius r is given by

$$A = nr^2 \cos \frac{180^\circ}{n} \sin \frac{180^\circ}{n}$$

Using the fact that the circle is the limiting position of the polygon as $n \rightarrow \infty$, show that the area A of the circle is $A = \pi r^2$.

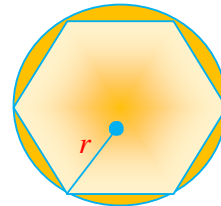

Figure 2.52

Proof:

$$\begin{aligned} A &= \lim_{n \rightarrow \infty} nr^2 \cos \frac{180^\circ}{n} \sin \frac{180^\circ}{n} = r^2 \lim_{n \rightarrow \infty} n \cos \frac{\pi}{n} \cdot \sin \frac{\pi}{n} \\ &= r^2 \lim_{n \rightarrow \infty} \cos \frac{\pi}{n} \cdot \lim_{n \rightarrow \infty} \frac{\sin\left(\frac{\pi}{n}\right)}{\frac{1}{n}} = r^2 \times 1 \times \pi = \pi r^2 \end{aligned}$$

Computation of e using the limit of a sequence



HISTORICAL NOTE

Leonhard Euler (1707-1783)

Swiss mathematician, whose major work was done in the field of pure mathematics. Euler was born in Basel and studied at the University of Basel under the Swiss mathematician Johann Bernoulli, obtaining his master's degree at the age of 16.



In his *Introduction to Analysis of the Infinite* (1748), Euler gave the first full analytical treatment of algebra, the theory of equations, trigonometry, and analytical geometry. In this work he treated the series expansion of functions and formulated the rule that only convergent infinite series can properly be evaluated.

He computed e to 23 decimal places using $\left(1 + \frac{1}{k}\right)^k$.

In **Grade 11**, you have used the irrational number e in expressions and formulae that model real world phenomena.

ACTIVITY 2.11



1 Consider the sequence $\left\{ \left(1 + \frac{1}{k}\right)^k \right\}_{k \geq 1}$

a Is the sequence monotone?

Justify your answer by filling up the values in the following table.

k	1	2	3	4	5	10	100	1000	10000
$\left(1 + \frac{1}{k}\right)^k$									

b Find the smaller positive integer k such that $\left(1 + \frac{1}{k}\right)^k$ is greater than 2.5, 2.7, 2.8.

c What do you see from the table as k increases?

d Find a positive integer n such that $n < \lim_{k \rightarrow \infty} \left(1 + \frac{1}{k}\right)^k < n + 1$

2 Let $f(x) = \left(1 + \frac{1}{x}\right)^x$

- a** What is the domain of f ?
- b** Look at the graph of f . Is f continuous on $(-1, 0]$? Why?
- c** Use the graph to evaluate $\lim_{x \rightarrow \infty} f(x)$ and $\lim_{x \rightarrow -\infty} f(x)$.

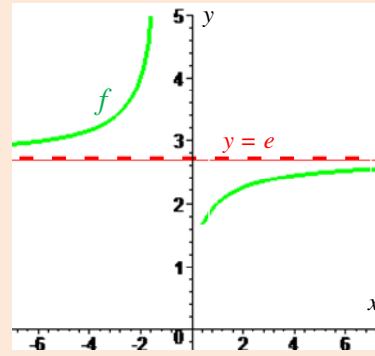

Figures 2.53

Theorem 2.8

$$\lim_{x \rightarrow \infty} \left(1 + \frac{1}{x}\right)^x = e \text{ and } \lim_{x \rightarrow -\infty} \left(1 + \frac{1}{x}\right)^x = e.$$

Example 3 Evaluate $\lim_{x \rightarrow \infty} \left(1 + \frac{1}{x}\right)^{x+100}$

Solution $\lim_{x \rightarrow \infty} \left(1 + \frac{1}{x}\right)^{x+100} = \lim_{x \rightarrow \infty} \left(1 + \frac{1}{x}\right)^x \cdot \lim_{x \rightarrow \infty} \left(1 + \frac{1}{x}\right)^{100} = e \left(\lim_{x \rightarrow \infty} \left(1 + \frac{1}{x}\right)\right)^{100} = e$. Why?

In general, you can show that $\lim_{x \rightarrow \infty} \left(1 + \frac{1}{x}\right)^{x+c} = e$ for $c \in \mathbb{R}$.

Example 4 Evaluate $\lim_{x \rightarrow \infty} \left(1 + \frac{9}{x}\right)^x$

Solution Let $\frac{1}{y} = \frac{9}{x}$, then $x = 9y$.

Thus, $\lim_{x \rightarrow \infty} \left(1 + \frac{9}{x}\right)^x = \lim_{y \rightarrow \infty} \left(1 + \frac{1}{y}\right)^{9y} = \left[\lim_{y \rightarrow \infty} \left(1 + \frac{1}{y}\right)^y\right]^9 = e^9$. Why?

In general, we can show that $\lim_{x \rightarrow \infty} \left(1 + \frac{c}{x}\right)^x = e^c$ for $c \in \mathbb{R}$

Example 5 Evaluate $\lim_{x \rightarrow \infty} \left(\frac{x}{3-x}\right)^x$.

Solution $\lim_{x \rightarrow \infty} \left(\frac{x}{x-3}\right)^x = \lim_{x \rightarrow \infty} \left(\frac{1}{\left(1 - \frac{3}{x}\right)^x}\right) = \frac{1}{e^{-3}} = e^3$

Example 6 Evaluate $\lim_{x \rightarrow -\infty} \left(\frac{5x+1}{5x-3} \right)^{1-4x}$

Solution
$$\lim_{x \rightarrow -\infty} \left(\frac{5x+1}{5x-3} \right)^{1-4x} = \lim_{x \rightarrow -\infty} \left(\frac{5x-3}{5x+1} \right)^{4x-1} = \left(\frac{1+\frac{-3}{5x}}{1+\frac{1}{5x}} \right)^{4x-1} = \left(\frac{e^{\frac{-3}{5}}}{e^{\frac{1}{5}}} \right)^4 = e^{-3.2}$$

(Explain!)

Exercise 2.9

1 Evaluate each of the following limits.

a $\lim_{x \rightarrow 0} \frac{\tan(4x)}{\tan(3x)}$

b $\lim_{x \rightarrow -2} \frac{\sin(x+2)}{x^3 + 2x^2 + x + 2}$

c $\lim_{x \rightarrow \frac{\pi}{2}} \frac{x - \frac{\pi}{2}}{\cos x}$

d $\lim_{x \rightarrow 0} \frac{\sin x}{x^3 - x}$

e $\lim_{x \rightarrow \pi} \frac{\sin x}{1 - \cos x}$

f $\lim_{x \rightarrow \infty} \frac{\sin x}{x}$

g $\lim_{x \rightarrow \infty} \left(1 - \frac{1}{x} \right)^{x+5}$

h $\lim_{x \rightarrow \infty} \left(\frac{x}{x+3} \right)^{8-5x}$

i $\lim_{x \rightarrow \infty} \left(\frac{x+4}{x-1} \right)^{3x-1}$

j $\lim_{x \rightarrow \infty} \left(\frac{2x+5}{2x-11} \right)^{x+1}$

k $\lim_{x \rightarrow 0^+} (5x+1)^{\frac{1}{x}}$

l $\lim_{x \rightarrow 0} \sin \left(\frac{1}{x} \right)$

m $\lim_{x \rightarrow \infty} \tan \left(\frac{1}{x} \right)$

2 *Continuous compounding formula*

Consider the compound interest formula. $A = P \left(1 + \frac{r}{100n} \right)^{nt}$

If the length of time period for compounding of the interest decreases from yearly to semi annually, quarterly, monthly, daily, hourly, etc, then the amount A increases

but the interest rate for the period decreases. That is, as $n \rightarrow \infty$, $\frac{r}{100n} \rightarrow 0$. In this

case, the interest is said to be compounded continuously. Find a formula for the amount A obtained when the interest is compounded continuously.

3 If Birr 4500 is deposited in an account paying 3% annual interest compounded continuously, then how much is in the account after 10 years and 3 months?



Key Terms

continuity	function	lower bound	null sequence
convergence	glb	lub	one side limit
decreasing	increasing	maximum	sequence
discontinuity	infinity	minimum	upper bound
divergence	limit	monotonic	



Summary

1 Upper bound and lower bound

- i A number m is called an **upper bound** of a sequence $\{a_n\}$, if and only if $m \geq a_i \forall a_i \in \{a_n\}$
- ii A number k is called a **lower bound** of a sequence $\{a_n\}$, if and only if $k \leq a_i \forall a_i \in \{a_n\}$

2 Least upper bound (lub) and greatest lower bound (glb).

- i A number ℓ is said to be the **least upper bound** (lub), if and only if ℓ is an upper bound and if y is an **upper bound**, then $\ell \leq y$.
- ii A number g is said to be the **greatest lower bound** (glb), if and only if g is a lower bound and if x is a lower bound, then $g \geq x$.

3 A sequence $\{a_n\}$ is said to be **monotonic**, if it is either increasing or decreasing.

4 A sequence $\{a_n\}$ is said to be a **null sequence**, if and only if $\lim_{n \rightarrow \infty} a_n = 0$.

5 Convergence properties of sequences

If $\lim_{n \rightarrow \infty} a_n = L$ and $\lim_{n \rightarrow \infty} b_n = M$, then

- i $\lim_{n \rightarrow \infty} (a_n \pm b_n) = L \pm M$
- ii $\lim_{n \rightarrow \infty} ca_n = cL$; where c is a constant.
- iii $\lim_{n \rightarrow \infty} (a_n b_n) = LM$
- iv $\lim_{n \rightarrow \infty} \frac{a_n}{b_n} = \frac{L}{M}$, provided that $M \neq 0$, and $b_n \neq 0$ for any n .

6 Limit of a function

- ✓ A number L is the limit of a function f at $x = a$, if and only if $f(x)$ approaches to L as x - approaches a but f need not be defined at a . This is expressed by

$$\lim_{x \rightarrow a} f(x) = L$$

7 One side limits

- i** A number L is said to be the right side limit of a function f at $x = a$, if and only if $f(x)$ approaches to L as x approaches to a from the right. This is expressed as: $\lim_{x \rightarrow a^+} f(x) = L$.

- ii** Likewise, we can define the **left hand side limit** and express it as:
 $\lim_{x \rightarrow a^-} f(x) = L$.

- iii** $\lim_{x \rightarrow a} f(x) = L$, if and only if $\lim_{x \rightarrow a^+} f(x) = \lim_{x \rightarrow a^-} f(x) = L$.

8 Basic limit theorems

If $\lim_{x \rightarrow a} f(x) = L$ and $\lim_{x \rightarrow a} g(x) = M$, then

- i** $\lim_{x \rightarrow a} (f(x) \pm g(x)) = L \pm M$ **ii** $\lim_{x \rightarrow a} cf(x) = cL$ for a constant c .

- iii** $\lim_{x \rightarrow a} (f(x) \cdot g(x)) = LM$ **iv** $\lim_{x \rightarrow a} \frac{f(x)}{g(x)} = \frac{L}{M}$ provided that $M \neq 0$.

9 Continuity

- i** A function f is said to be continuous at $x = x_0$, if the following three conditions are met.

a $f(x_0)$ is defined **b** $\lim_{x \rightarrow x_0} f(x)$ exist **c** $\lim_{x \rightarrow x_0} f(x) = f(x_0)$

- ii** A function is continuous on an open interval (a, b) , if it is continuous at each number in the interval.

- iii** A function f is continuous on a closed interval $[a, b]$, if it is continuous on (a, b) and $\lim_{x \rightarrow a^+} f(x) = f(a)$ and $\lim_{x \rightarrow b^-} f(x) = f(b)$.

- iv** A function f is said to be continuous, if it is continuous on its entire domain.

10 Properties of continuous functions

If f and g are functions that are continuous at $x = x_0$ and c is a real number, then the following functions are continuous at x_0 .

- i** scalar multiple: cf **ii** sum and difference $f \pm g$

- iii** product: fg **iv** quotient: $\frac{f}{g}$ provided that $g(x_0) \neq 0$.

11 Continuity of composite functions

If g is continuous at $x = x_0$ and f is continuous at $y = g(x_0)$, then the composite function given by $(f \circ g)(x) = f(g(x))$ is continuous at $x = x_0$.

12 Intermediate value theorem

If f is continuous on $[a, b]$ and k is any real number between $f(a)$ and $f(b)$, then there is at least one number c between a and b such that $f(c) = k$.

13 Extreme value theorem

Let f be a continuous function on the closed interval $[a, b]$. Then there exist two real numbers x_1 and x_2 in $[a, b]$ such that $f(x_2) \leq f(x) \leq f(x_1)$ for all $x \in [a, b]$. In this case $f(x_2)$ is the minimum value of the function f on $[a, b]$ and $f(x_1)$ is the maximum value of f on $[a, b]$.

14 Two important limits

i $\lim_{x \rightarrow 0} \frac{\sin x}{x} = 1$

ii $\lim_{x \rightarrow \pm\infty} \left(1 + \frac{1}{x}\right)^x = e$



Review Exercises on Unit 2

1 Evaluate each of the following limits.

a $\lim_{x \rightarrow 0} (2x - 1)$

b $\lim_{x \rightarrow -1} \frac{x + 1}{x^2 + 7x + 6}$

c $\lim_{x \rightarrow 9} \frac{\sqrt{x} - 3}{x^2 - 81}$

d $\lim_{x \rightarrow 0} \frac{\sqrt{x + 4} - 2}{x}$

e $\lim_{x \rightarrow 0} \frac{\cos x}{x}$

2 Let $f(x) = \frac{x |x - 5|}{x^2 - 25}$, evaluate

a $\lim_{x \rightarrow 5^+} f(x)$

b $\lim_{x \rightarrow 5^-} f(x)$

c $\lim_{x \rightarrow 5} f(x)$

d $\lim_{x \rightarrow -5} f(x)$

3 Let $f(x) = \begin{cases} 3, & \text{if } x = -5 \\ -0.6, & \text{if } -5 < x \leq -2 \\ x^2 - 4, & \text{if } -2 < x < 3 \\ x + 2, & \text{if } x \geq 3 \end{cases}$

Sketch the graph of f and evaluate each of the following limits.

a $\lim_{x \rightarrow 5} f(x)$

b $\lim_{x \rightarrow -2} f(x)$

c $\lim_{x \rightarrow 3} f(x)$

4 Evaluate each of the following limits.

a $\lim_{x \rightarrow 3} (x^3 - 4x^2 + 5x - 11)$

b $\lim_{x \rightarrow 2} \sqrt{x^2 - 5x}$

$$\mathbf{c} \quad \lim_{x \rightarrow 7} \frac{x^2 - 49}{x^2 + 6x - 7}$$

$$\mathbf{e} \quad \lim_{x \rightarrow -5} \frac{x^3 + 125}{x + 5}$$

$$\mathbf{g} \quad \lim_{x \rightarrow \infty} \sin \left(\frac{\pi}{x} \right)$$

$$\mathbf{i} \quad \lim_{x \rightarrow 0} \frac{\sin x}{x \cos x}$$

$$\mathbf{d} \quad \lim_{x \rightarrow 0} \frac{3x - 4|x|}{5x}$$

$$\mathbf{f} \quad \lim_{x \rightarrow 1} \frac{\sin(x-1) + x^2 - 1}{x-1}$$

$$\mathbf{h} \quad \lim_{x \rightarrow \infty} \cos x$$

$$\mathbf{j} \quad \lim_{x \rightarrow 0} \frac{\sin^3(5x)}{\sin(4x^3)}$$

5 Test whether or not each of the given functions is continuous at the indicated number.

$$\mathbf{a} \quad f(x) = \begin{cases} x^2 - x, & \text{if } x \geq 1 \\ x + 1, & \text{if } x < 1 \end{cases}; x = 1$$

$$\mathbf{b} \quad f(x) = \frac{x^2 |9 - x^2|}{3 - x}; x = 3$$

$$\mathbf{c} \quad f(x) = \begin{cases} \frac{\sin x}{x}, & \text{if } x \neq 0 \\ 1, & \text{if } x = 0 \end{cases}; x = 0$$

$$\mathbf{d} \quad f(x) = \begin{cases} \frac{1}{4}, & \text{if } x \notin \mathbb{Z} \\ 4^x, & \text{if } x \in \mathbb{Z} \end{cases}; x = \frac{1}{2}$$

$$\mathbf{e} \quad f(x) = \begin{cases} \frac{\cos x}{e^x}, & \text{if } x > 0 \\ e^x, & \text{if } x \leq 0 \end{cases}; x = 0$$

6 Determine the values of the constants so that each of the given functions is continuous.

$$\mathbf{a} \quad f(x) = \begin{cases} ax - 1, & \text{if } x \leq 2 \\ x^2 + 3x, & \text{if } x > 2 \end{cases}$$

$$\mathbf{b} \quad f(x) = \begin{cases} \frac{x^2 - ax}{x - a}, & \text{if } x \neq a \\ 2, & \text{if } x = a \end{cases}$$

$$\mathbf{c} \quad f(x) = f(x) = \begin{cases} \sin(k+x), & \text{if } x \leq 0 \\ 1, & \text{if } x > 0 \end{cases}$$

$$\mathbf{d} \quad f(x) = \begin{cases} x^2 + 1, & \text{if } x < a \\ 15 - 5x, & \text{if } a \leq x \leq b \\ 5x - 25, & \text{if } x > b \end{cases}$$

7 Evaluate each of the following limits.

$$\mathbf{a} \quad \lim_{x \rightarrow \infty} \frac{3x^3 + 5x^2 - 11}{2x^3 - 1}$$

$$\mathbf{b} \quad \lim_{x \rightarrow \infty} \frac{\sqrt{x^2 + 1} - 10}{\sqrt{x^2 + 1} + 9}$$

8 Evaluate each of the following one side limits.

$$\mathbf{a} \quad \lim_{x \rightarrow 0^+} |x| - 3x$$

$$\mathbf{b} \quad \lim_{x \rightarrow 3^+} \sqrt{3 - x}$$

$$\mathbf{c} \quad \lim_{x \rightarrow 3^-} \sqrt{3x - 9}$$

$$\mathbf{d} \quad \lim_{x \rightarrow 0^+} \ln x$$

$$\mathbf{e} \quad \lim_{x \rightarrow 5^+} \frac{x}{(x-5)^3}$$

$$\mathbf{f} \quad \lim_{x \rightarrow 2^+} \sqrt{1 - \sqrt{x-1}}$$

g $\lim_{x \rightarrow 0^+} \frac{\sin x}{\sqrt{x}}$ **h** $\lim_{x \rightarrow -5^-} \sqrt{25 - x^2}$ **i** $\lim_{x \rightarrow 7^-} \frac{x^2 |x^2 - 49|}{x - 7}$

9 Determine the largest interval on which each of the given functions is continuous.

a $f(x) = \sqrt{\frac{1-x}{x}}$ **b** $f(x) = \sqrt{\ln \sqrt{x}}$
c $f(x) = \ln\left(\frac{x}{e^x - 1}\right)$ **d** $f(x) = \sqrt{\frac{4x-3}{x-4}}$

10 Determine the maximum and minimum values of each of the functions defined on the indicated closed interval.

a $f(x) = 3x + 5$; $[-3, 2]$ **b** $g(x) = 1 - x^2$; $[-2, 3]$
c $h(x) = x^4 - x^2$; $[-2, 2]$ **d** $f(x) = \frac{1}{x}$; $[-2, 2]$
e $h(x) = 4x^2 - 5x + 1$; $[-1.5, 1.5]$ **f** $f(x) = \begin{cases} x^2, & \text{if } |x| \leq 1 \\ 2 - |x|, & \text{if } |x| > 1; \end{cases} [-3, 2]$

11 Locate the zeros of each of the following functions using the **intermediate value theorem**.

a $f(x) = x^2 - x - 1$ **b** $g(x) = x^3 + 2x^2 - 5$
c $h(x) = x^3 - x + 2$ **d** $f(x) = x^4 - 2x^3 - x^2 + 3x - 2$
e $g(x) = x^4 - 9x^2 + 14$

12 Evaluate each of the following limits.

a $\lim_{x \rightarrow 0} \frac{\sin\left(\frac{x}{\pi}\right)}{\tan x}$ **b** $\lim_{x \rightarrow 0} \frac{\sin(x^3)}{x^3}$ **c** $\lim_{x \rightarrow \infty} x \tan\left(\frac{1}{x}\right)$
d $\lim_{x \rightarrow 0} \frac{x - \tan x}{x}$ **e** $\lim_{x \rightarrow \infty} \left(1 + \frac{3}{x+11}\right)^{x+6}$

13 In a certain country, the life expectancy for males x -years from now is given by the formula $f(x) = \frac{210x+116}{3x+4}$ years. What will be the life expectancy of males in this country as time passes? Discuss whether or not the life expectancy in the country is increasing.

14 A girl enrolling in typing class types $\frac{60(x+1)}{x+9}$ words per minute after x weeks of lessons. Determine the maximum possible number of words the girl can type as time passes.

Unit

3

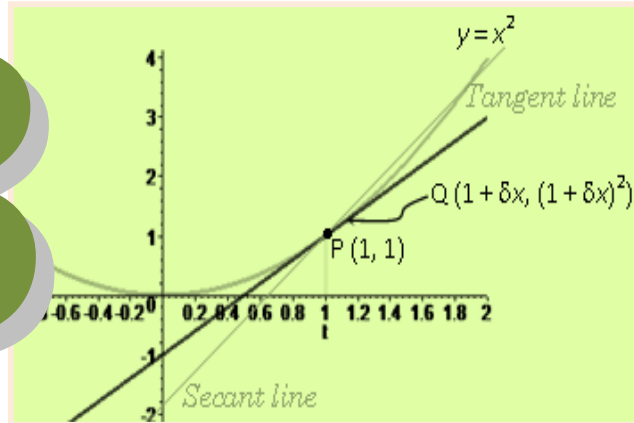

INTRODUCTION TO DIFFERENTIAL CALCULUS

Unit Outcomes:

After completing this unit, you should be able to:

- describe the geometrical and mathematical meaning of derivative.
- determine the differentiability of a function at a point.
- find the derivatives of some selected functions over intervals.
- apply the sum, difference, product and quotient rule of differentiation of functions.
- find the derivatives of power functions, polynomial functions, rational functions, simple trigonometric functions, exponential and logarithmic functions.

Main Contents

3.1 INTRODUCTION TO DERIVATIVES

3.2 DERIVATIVES OF SOME FUNCTIONS

3.3 DERIVATIVES OF COMBINATIONS AND COMPOSITIONS OF FUNCTIONS

Key terms

Summary

Review Exercises

INTRODUCTION

In every aspect of our life, we encounter things that change according to some well recognizable rules or forms. In the study of many physical phenomena, for example, we always see changing quantities: the speed of a car, the inflation of prices of goods, the number of bacteria in a culture, the shock intensity of an earthquake, the voltage of an electric signal and so on.

In order to deal with quantities which change at variable rate, you need the notion of differential calculus. Moreover, notions such as how fast/slow things are changing, what is the most suitable quantity to be chosen from among different alternatives are studied in the differential calculus.

In this unit you are going to study the meaning and methods of differentiation. The unit begins by considering slope as a rate of change.

3.1 INTRODUCTION TO DERIVATIVES

3.1.1 Understanding Rates of Change

ACTIVITY 3.1



- 1 Consider a circle of radius 3 cm.
 - a If the radius increases by 1 cm, find the change in the circumference of the circle.
 - b If the radius increases by 1 cm/s find the circumference of the circle when $t = 1$ s, 2 s, 3 s
 - c What is the time rate of change of the circumference when the radius increases 1 cm/s?

The following table shows the time t , the radius r and the circumference c .

From the following table, what is the rate of change of the circumference?

t	1 s	2 s	3 s
r	4 cm	5 cm	6 cm
$c = 2\pi r$	8π cm	10π cm	12π cm

- d** If Δr is the increase in the radius and Δc is the increase in the circumference, then $\Delta c = 2\pi(\Delta r + 3 \text{ cm}) - 2\pi(3 \text{ cm}) = 2\pi(\Delta r)$.

Let Δt be the increase in the time. If $\frac{\Delta r}{\Delta t} = 1 \text{ cm/s}$, what is $\frac{\Delta c}{\Delta t}$?

2 *Average rate of change and instantaneous rates of change.*

Suppose you drove 200 km in 4 hours, then the average speed at which you drove is 50 km/hr. *This is the average rate of change.*

The average speed for the whole journey is the constant speed that would be required to cover the total distance in the same time.

Suppose you drove at 30 km/hr for 2 km and then at 120 km/hr for 2 km.

- a** What is your average speed?
b Is a patrol officer going to stop you for speeding?
c Is the officer likely to consider your lower average speed and not charge you?

Here what is considered is the speed at a particular instant.

3 Suppose a particle moves along a straight line from a fixed-point **O** on that line. The following table shows the distance of the particle from point **O** at a given instant of time t .

t (s)	0	1	2	3	4	5
position (m)	4	4	4	4	4	4

- a** Draw the position - time graph.
b Find the gradient (slope) of the graph.
c Find the speed of the particle in the interval of time $t = 0$ to $t = 1$, $t = 1$ to $t = 2$, ..., $t = 4$ to $t = 5$.

4 Repeat **Problem 3** for this new data.

i

t (s)	0	1	2	3	4	5
position (m)	0	1	2	3	4	5

ii

t (s)	0	1	2	3	4	5
position (m)	0	20	40	60	80	100

5 From the position - time graphs, what is the relationship between the gradient (or slope) and the speed in the given intervals of time?

In **Activity 3.1**, the position-time graphs are all straight lines and the speed is represented by the gradient (or the slope) of the line.

Now, let's consider a position-time graph which is not a straight line.

Example 1 Suppose a particle moves along a straight line from point O on that line. The position d of the particle from point O at a given instant of time t are shown below.

t (seconds)	1	2	3	4	5
position (m)	1	4	9	16	25

- a** Draw a position - time graph.
- b** Let A, B, C, D, E, and F be points on the graph when $t = 0, 1, 2, 3, 4, 5$ respectively.

Find the gradients of the chords AB, BC, CD, DE and EF.

- c** Find the average speeds over these intervals of time.
 - i** $t = 0$ to $t = 1$ **ii** $t = 1$ to $t = 2$ **iii** $t = 2$ to $t = 3$
 - v** $t = 4$ to $t = 5$ **iv** $t = 3$ to $t = 4$

Solution From the table, it is observed that different distances are covered in equal intervals of time. Thus the position - time graph is not a straight line.

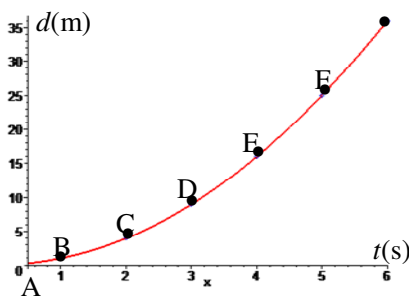

Figure 3.1

Chord	AB	BC	CD	DE	EF
Gradient	1	3	5	7	9
Average speed(m/s)	1	3	5	7	9

Example 2 A particle moves along a straight line from a fixed-point O on that line. The position d in metres of the particle from point O as a function of time t in second is given by $d = (t + 2)(4 - t)$.

- a** Draw the position-time graph for the interval of time $t = 0$ to $t = 5$.
- b** Using the graph, find the average speed of the particle over the intervals $t = 0$ to $t = 1$, $t = 1$ to $t = 2$, $t = 2$ to $t = 3$, $t = 3$ to $t = 4$, $t = 4$ to $t = 5$.
- c** Find the time at which the speed is 0.
- d** Approximate the gradient of the graph at $t = 2$.

Solution

a

t (s)	0	1	2	3	4	5
$d = (t + 2)(4 - t)$	8	9	8	5	0	-7

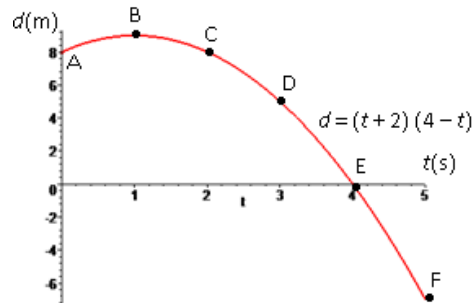

Figure 3.2

b

time interval $t = a$ to $t = b$	0 to 1	1 to 2	2 to 3	3 to 4	4 to 5
chord	AB	BC	CD	DE	EF
gradient	$\frac{9-8}{1} = 1$	$8-9 = -1$	$5-8 = -3$	$0-5 = -5$	$-7-0 = -7$
Average speed	1 m/s	-1 m/s	-3 m/s	-5 m/s	-7 m/s

- c** From the graph one can see that the gradient at B, when $t = 1$, is zero. i.e., the graph has a horizontal tangent line at $t = 1$.
- d** There will be a very good approximation, if you consider very small intervals of time.

Let Δt be the increase in time and Δd be the increase in distance.

If $t = 2 + \Delta t$, then

$$\Delta d = (2 + \Delta t + 2)(4 - (2 + \Delta t)) = (4 + \Delta t)(2 - \Delta t). \text{ Since at } t = 2, d = 8,$$

$$\begin{aligned} \text{the gradient at } c &= \frac{(4 + \Delta t)(2 - \Delta t) - 8}{2 + \Delta t - 2} \\ &= \frac{8 - 2\Delta t - \Delta t^2 - 8}{\Delta t} \\ &= \frac{-(\Delta t)^2 - 2\Delta t}{\Delta t} = -\Delta t - 2 \end{aligned}$$

As $\Delta t \rightarrow 0$, $-\Delta t - 2 \rightarrow -2$.

The gradient when $t = 2$ is -2 .

By a similar technique, we can find that the velocity, $v(t) = 2 - 2t$.

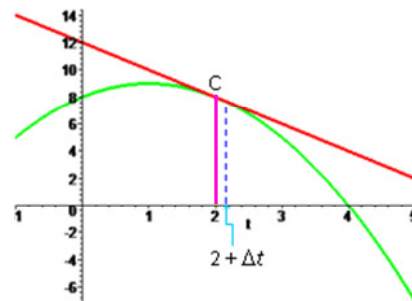

Figures 3.3

Velocity-time graph

t (s)	0	1	2	3	4	5
Velocity m/s	2	0	-2	-4	-6	-8

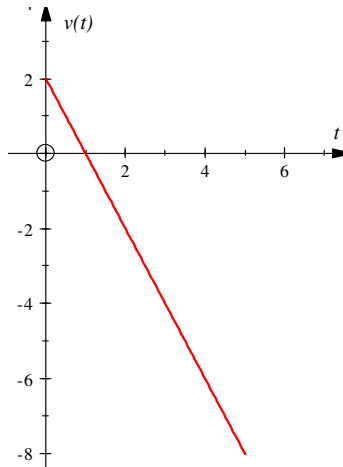

Figure 3.4

3.1.2 Graphical Definition of Derivative

The slope (gradient) of the graph of $y = f(x)$ at point P

Newton and Leibniz invented calculus at about the same time.



HISTORICAL NOTE

Sir Isaac Newton (1642-1727)

Isaac Newton's work represents one of the greatest contributions to science ever made by an individual. Most notably, Newton derived the law of universal gravitation, invented the branch of mathematics called calculus, and performed experiments investigating the nature of light and colour.



Gottfried Wilhelm Leibniz (1646-1716)



The 17th-century thinker **Gottfried Leibniz** made contributions to a variety of subjects, including theology, history, and physics, although he is best remembered as a mathematician and philosopher. According to Leibniz, the world is composed of monads—tiny units, each of which mirrors and perceives the other monads in the universe.

Definition 3.1 Secant line and tangent line

A line which intersects a (continuous) graph in exactly two points is said to be a **secant line**.

A line which touches a graph at exactly one point is said to be a **tangent line** at that point. The intersection point is said to be the **point of tangency**.

The slope of the graph of a function at a point P is the slope of the tangent line at point P.

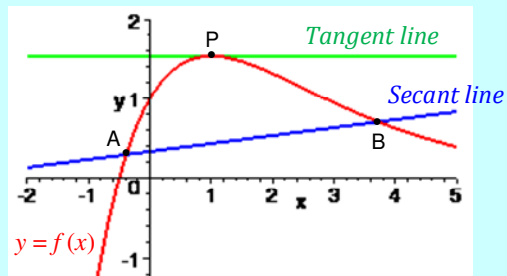

Figure 3.5

Example 3 Consider the graph of $y = x^2$.

- a** Find the slope of the secant line passing through $(1, 1)$ and $(2, 4)$.
- b** Find the slope of the tangent line at $(1, 1)$.

Solution

- a** the slope of the secant line = $\frac{4 - 1}{2 - 1} = 3$.

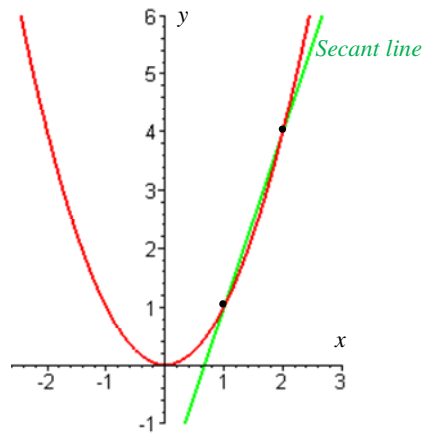

Figure 3.6

This is the average rate of change of y on the interval $[1, 2]$.

In general, the average rate of change of a function f on $[x_1, x_2]$, $x_1 < x_2$, is the slope (or gradient) of the secant line passing through the two points $(x_1, f(x_1))$ and $(x_2, f(x_2))$.

So average rate of change = $\frac{f(x_2) - f(x_1)}{x_2 - x_1}$. (See Figure 3.7)

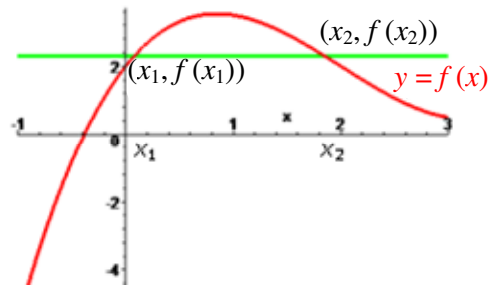

Figure 3.7

b

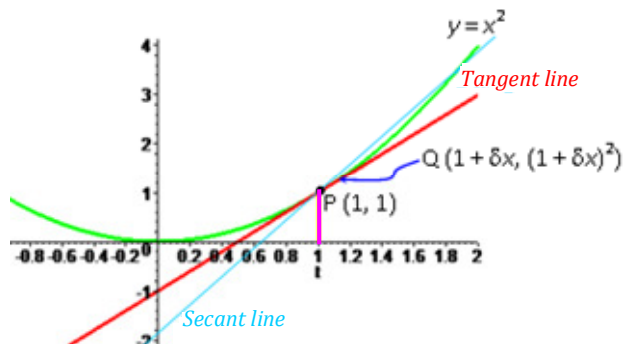

Figure 3.8

Let Q be another point on the graph of $y = x^2$ such that the increase in the x -coordinate in moving from P to Q is δx .

Then Q has coordinates $(1 + \delta x, (1 + \delta x)^2)$.

Hence, the slope of the secant line is

$$\frac{(1 + \delta x)^2 - 1}{1 + \delta x - 1} = \frac{1 + 2\delta x + (\delta x)^2 - 1}{\delta x} = 2 + \delta x$$

Notice that the tangent line is the limit of the secant lines through

$$(1 + \delta x, (1 + \delta x)^2) \text{ as } \delta x \rightarrow 0.$$

Thus, the slope of the tangent line at $(1, 1)$ is

$$\lim_{\delta x \rightarrow 0} (2 + \delta x) = 2$$

In general, the instantaneous rate of change of $f(x)$ at $(x_0, f(x_0))$ is represented by the slope of the tangent line at $(x_0, f(x_0))$.

Functional notation to find the slope of $y = f(x)$ at point P

Gradient of the secant line

$$= \frac{f(x+h) - f(x)}{(x+h) - x} = \frac{f(x+h) - f(x)}{h}$$

Using the same method as with the delta notation, you have gradient of the tangent line at P

$$= \lim_{h \rightarrow 0} \frac{f(x+h) - f(x)}{h}$$

Example 4 Let $f(x) = 2x^2 - 5x + 1$. Find the gradient of the line tangent to the graph of f at $(2, -1)$.

Solution

$$\begin{aligned} \text{gradient} &= \lim_{h \rightarrow 0} \frac{f(2+h) - f(2)}{h} \\ &= \lim_{h \rightarrow 0} \frac{2(2+h)^2 - 5(2+h) + 1 - (-1)}{h} \\ &= \lim_{h \rightarrow 0} \frac{8 + 8h + 2h^2 - 5h - 8}{h} \\ &= \lim_{h \rightarrow 0} \frac{3h + 2h^2}{h} = \lim_{h \rightarrow 0} (3 + 2h) = 3. \end{aligned}$$

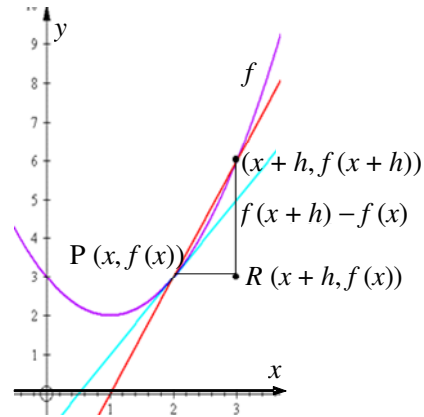

Figure 3.9

Limit of the quotient difference

Let $f(x)$ be a function defined in a neighbourhood of a point x_0 .

The ratio $\frac{f(x) - f(x_0)}{x - x_0}$ is called the **quotient difference** of f at $x = x_0$.

Example 5 Find the quotient-difference of each of the following functions for the given values of x_0 .

- a** $f(x) = x + 1; x_0 = 3$ **b** $f(x) = x^2 - 2x + 3; x_0 = -1$
c $f(x) = x^3 - 4x + 1; x_0 = 1$

Solution

a $\frac{f(x) - f(3)}{x - 3} = \frac{(x + 1) - 4}{x - 3} = \frac{x - 3}{x - 3} = 1; x \neq 3$

b $\frac{f(x) - f(-1)}{x - (-1)} = \frac{x^2 - 2x + 3 - (1 + 3 - 2(-1))}{x + 1} = \frac{x^2 - 2x + 3 - 6}{x + 1}$
 $= \frac{x^2 - 2x - 3}{x + 1} = \frac{(x - 3)(x + 1)}{x + 1} = (x - 3); x \neq -1$

$$\begin{aligned} \mathbf{c} \quad \frac{f(x) - f(1)}{x - 1} &= \frac{x^3 - 4x + 1 - (1 - 4 + 1)}{x - 1} = \frac{x^3 - 4x + 3}{x - 1} \\ &= \frac{(x-1)(x^2 + x - 3)}{x - 1} = x^2 + x - 3; \quad x \neq 1 \end{aligned}$$

If the limit of the quotient difference as $x \rightarrow x_0$ exists, then it is said to be the derivative of $f(x)$ at $x = x_0$. In the above examples,

$$\mathbf{a} \quad \lim_{x \rightarrow 3} \frac{f(x) - f(3)}{x - 3} = \lim_{x \rightarrow 3} \frac{(x - 3)}{x - 3} = 1.$$

\Rightarrow The derivative of $f(x) = x + 1$ at $x = 3$ is 1.

$$\mathbf{b} \quad \lim_{x \rightarrow -1} \frac{f(x) - f(-1)}{x - (-1)} = \lim_{x \rightarrow -1} \frac{(x-3)(x+1)}{x+1} = \lim_{x \rightarrow -1} x - 3 = -4$$

\Rightarrow The derivative of $f(x) = 3 - 2x + x^2$ at $x = -1$ is -4 .

$$\mathbf{c} \quad \lim_{x \rightarrow 1} \frac{f(x) - f(1)}{x - 1} = \lim_{x \rightarrow 1} \frac{(x-1)(x^2 + x - 3)}{x - 1} = \lim_{x \rightarrow 1} (x^2 + x - 3) = -1$$

\Rightarrow The derivative of $f(x) = x^3 - 4x + 1$ at $x = 1$ is -1 .

Exercise 3.1

1 Let $f(x) = x^2 - x + 3$. Find

$$\mathbf{a} \quad \lim_{h \rightarrow 0} \frac{f(3+h) - f(3)}{h}$$

$$\mathbf{b} \quad \lim_{\delta x \rightarrow 0} \frac{f(-1 + \delta x) - f(-1)}{\delta x}$$

$$\mathbf{c} \quad \lim_{x \rightarrow 4} \frac{f(x) - f(4)}{x - 4}$$

2 Find the slope of each of the following functions at the given points.

$$\mathbf{a} \quad f(x) = x^2; (-3, 9)$$

$$\mathbf{b} \quad g(x) = 1 - 3x^2; (1, -2)$$

$$\mathbf{c} \quad h(x) = \frac{1}{x}; \left(\frac{1}{2}, 2\right)$$

$$\mathbf{d} \quad k(x) = \sqrt{x}; (9, 3)$$

$$\mathbf{e} \quad f(x) = \frac{3x - 1}{5x - 3}; \left(-3, \frac{5}{9}\right)$$

$$\mathbf{f} \quad f(x) = \sqrt{x}; (4, 2)$$

$$\mathbf{g} \quad f(x) = \begin{cases} x, & \text{if } x < 0 \\ x^2, & \text{if } x \geq 0 \end{cases}; (0, 0)$$

$$\mathbf{h} \quad f(x) = \begin{cases} x^2 + 2; & x \geq -2; (-2, 6) \\ 4x - 2; & x < -2 \end{cases}$$

$$\mathbf{i} \quad f(x) = \begin{cases} \sqrt{1-x}; & 0 \leq x \leq 1 \\ x^2 + 1; & x < 0; (0, 1) \end{cases}$$

3.1.3 Differentiation of a Function at a Point

Definition 3.2

Let f be a function and x_0 be in the domain of f .

If $\lim_{x \rightarrow x_0} \frac{f(x) - f(x_0)}{x - x_0}$ exists, we say that the graph of f has a tangent line at $(x_0, f(x_0))$.

In that case the line tangent to the graph of f at $(x_0, f(x_0))$ is defined to be the line through $(x_0, f(x_0))$ with this limit as its slope.

Example 6 Find the equation of the line tangent to the graph of $f(x) = x^2 - 2$ at $(1, -1)$.

Solution By the **Definition of the slope**, m of the tangent line,

$$m = \lim_{x \rightarrow 1} \frac{f(x) - f(1)}{x - 1} = \lim_{x \rightarrow 1} \frac{x^2 - 2 - (-1)}{x - 1} = \lim_{x \rightarrow 1} \frac{x^2 - 1}{x - 1} = \lim_{x \rightarrow 1} (x + 1) = 2$$

\Rightarrow The slope of the tangent line is 2.

The equation of the tangent line is

$$y - (-1) = 2(x - 1) \Rightarrow y = 2x - 3.$$

Example 7 Find the equation of the line tangent to the graph of $y = \sin x$ at $\left(\frac{\pi}{2}, 1\right)$.

Solution The slope of the tangent line, $m = \lim_{x \rightarrow \frac{\pi}{2}} \frac{\sin x - \sin \frac{\pi}{2}}{x - \frac{\pi}{2}}$

Let $z = x - \frac{\pi}{2}$, then $x = z + \frac{\pi}{2}$ and as $x \rightarrow \frac{\pi}{2}$, $z \rightarrow 0$

$$\begin{aligned} \text{Thus, } m &= \lim_{z \rightarrow 0} \frac{\sin\left(z + \frac{\pi}{2}\right) - \sin \frac{\pi}{2}}{z} = \lim_{z \rightarrow 0} \frac{\sin z \cos \frac{\pi}{2} + \cos z \sin \frac{\pi}{2} - 1}{z} \\ &= \lim_{z \rightarrow 0} \frac{\cos z - 1}{z} = 0 \Rightarrow \text{The equation of the tangent line is } y = 1. \end{aligned}$$

Definition 3.3

Let f be a continuous function at x_0 .

If $\lim_{x \rightarrow x_0} \frac{f(x) - f(x_0)}{x - x_0} = \infty$ or $\lim_{x \rightarrow x_0} \frac{f(x) - f(x_0)}{x - x_0} = -\infty$, then the vertical line $x = x_0$ is

tangent to the graph of f at $(x_0, f(x_0))$.

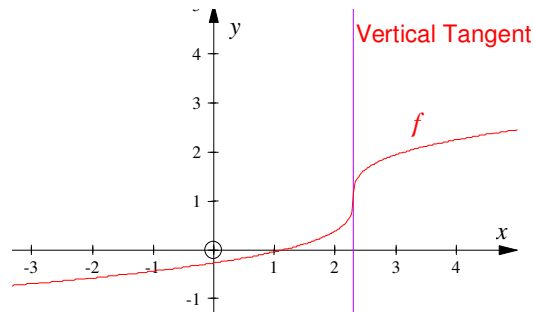

Figure 3.10

Example 8 Find the equation of the line tangent to the graph of $f(x) = x^{\frac{1}{3}}$ at $x = 0$.

Solution Look at the graph of f . It is continuous on \mathbb{R} . So it is continuous at 0.

$$\text{But, } \lim_{x \rightarrow 0} \frac{x^{\frac{1}{3}} - 0}{x - 0} = \infty.$$

\Rightarrow The line $x = 0$ (the y -axis) is tangent to the graph of f at $(0, 0)$.

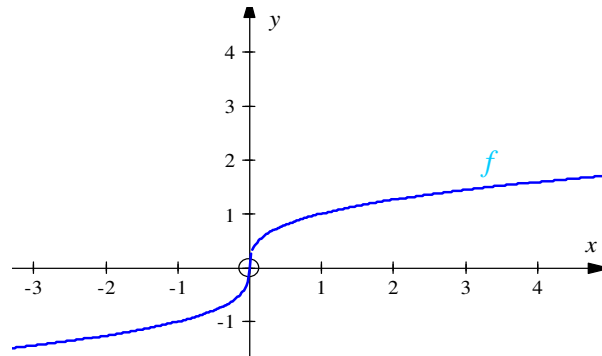

Figure 3.11

The derivative

Definition 3.4

Let x_0 be in the domain of a function f .

If $\lim_{x \rightarrow x_0} \frac{f(x) - f(x_0)}{x - x_0}$ exists, then we call this limit the derivative of f at x_0 .

NOTATION

The derivative of f at x_0 is denoted by $f'(x_0)$, which is read as ' f prime of x_0 '.

If $f'(x_0)$ exists, then we say that f has a derivative at x_0 or f is differentiable at x_0 .

Differentiation is the process of finding the derivative of a function.

Example 9 Find the derivative of each of the following functions at the given number.

- a** $f(x) = 4x + 5; x_0 = 2$ **b** $f(x) = \frac{1}{4}x^2 + x; x_0 = -1$
c $f(x) = x^3 - 9x; x_0 = \frac{1}{3}$ **d** $f(x) = \sqrt{x}; x_0 = 4$

Solution Using the **Definition**,

$$f'(x_0) = \lim_{x \rightarrow x_0} \frac{f(x) - f(x_0)}{x - x_0}, \text{ you obtain,}$$

$$\mathbf{a} \quad f'(2) = \lim_{x \rightarrow 2} \frac{(4x+5) - (4(2)+5)}{x-2} = \lim_{x \rightarrow 2} \frac{4x-8}{x-2} = \lim_{x \rightarrow 2} \frac{4(x-2)}{x-2} = 4.$$

$$\begin{aligned} \mathbf{b} \quad f'(-1) &= \lim_{x \rightarrow -1} \frac{\frac{1}{4}x^2 + x - \left(\frac{1}{4}(-1)^2 - 1\right)}{x - (-1)} = \lim_{x \rightarrow -1} \frac{\frac{1}{4}x^2 + x + \frac{3}{4}}{x+1} \\ &= \lim_{x \rightarrow -1} \frac{\frac{1}{4}(x+3)(x+1)}{x+1} = \frac{1}{4} \lim_{x \rightarrow -1} (x+3) = \frac{1}{2}. \end{aligned}$$

$$\begin{aligned} \mathbf{c} \quad f'\left(\frac{1}{3}\right) &= \lim_{x \rightarrow \frac{1}{3}} \frac{x^3 - 9x - \left(\left(\frac{1}{3}\right)^3 - 9\left(\frac{1}{3}\right)\right)}{x - \frac{1}{3}} = \lim_{x \rightarrow \frac{1}{3}} \frac{\left(x^2 + \frac{1}{3}x - \frac{80}{9}\right)\left(x - \frac{1}{3}\right)}{x - \frac{1}{3}} \\ &= \left(\frac{1}{3}\right)^2 + \frac{1}{3} \times \frac{1}{3} - \frac{80}{9} = \frac{-26}{9}. \end{aligned}$$

$$\mathbf{d} \quad f'(x) = \lim_{x \rightarrow 4} \frac{\sqrt{x} - 2}{x - 4} = \lim_{x \rightarrow 4} \frac{\sqrt{x} - 2}{(\sqrt{x} - 2)(\sqrt{x} + 2)} = \lim_{x \rightarrow 4} \frac{1}{\sqrt{x} + 2} = \frac{1}{4}$$

Let f be a function defined at a . If $f'(a)$ exists, then the graph of f has a tangent line at $(a, f(a))$ and the equation of the tangent line is

$$y - f(a) = f'(a)(x - a)$$

Example 10 Find the equation of the line tangent to the graph of $f(x) = x^2$ at

- a** $x = 1$, **b** $x = 0$, **c** $x = -5$

Solution $f(x) = x^2 \Rightarrow f'(x) = 2x$

a $f(1) = 1$ and $f'(1) = 2$

\Rightarrow The equation of the tangent line is:

$$y - f(1) = f'(1)(x - 1) \Rightarrow y - 1 = 2(x - 1) \Rightarrow y = 2x - 1$$

b $y - f(0) = f'(0)(x - 0) \Rightarrow y = 0$

c $y - f(-5) = f'(-5)(x - (-5))$

$$\Rightarrow y - 25 = -10(x + 5) \Rightarrow y = -10x - 25$$

Example 11 Find the equations of the lines tangent to the graph of $f(x) = x^3 + 1$ at

- a** $x = -2$ **b** $x = -1$ **c** $x = 2$

Solution
$$f'(a) = \lim_{x \rightarrow a} \frac{f(x) - f(a)}{x - a} = \lim_{x \rightarrow a} \frac{x^3 + 1 - (a^3 + 1)}{x - a} = \lim_{x \rightarrow a} \frac{x^3 - a^3}{x - a}$$

$$= \lim_{x \rightarrow a} \frac{(x - a)(x^2 + ax + a^2)}{x - a} = \lim_{x \rightarrow a} (x^2 + ax + a^2)$$

$$= a^2 + a^2 + a^2 = 3a^2$$

Therefore,

a $f'(-2) = 3(-2)^2 = 12$

\Rightarrow The equation of the line tangent to the graph of f at $x = -2$ is

$$y - f(-2) = 12(x - (-2))$$

$$\Rightarrow y - (-7) = 12(x + 2) \Rightarrow y = 12x + 17$$

b $f'(-1) = 3(-1)^2 = 3$

\Rightarrow The equation of the line tangent to the graph of f at $x = -1$ is

$$y - f(-1) = 3(x - (-1))$$

$$\Rightarrow y - 0 = 3x + 3 \Rightarrow y = 3x + 3$$

c $f'(2) = 3(2)^2 = 12$

The equation of the tangent line at $x = 2$ is

$$y - f(2) = 12(x - 2) \Rightarrow y - 9 = 12x - 24$$

$$\Rightarrow y = 12x - 15$$

Example 12 Let $f(x) = \begin{cases} x^2, & \text{if } x \geq 0 \\ x^3, & \text{if } x < 0 \end{cases}$

Determine the equation of the line tangent to the graph of f at $x = 0$.

Solution
$$f'(0) = \lim_{x \rightarrow 0} \frac{f(x) - f(0)}{x - 0} = \lim_{x \rightarrow 0} \frac{f(x)}{x}$$

Here, we consider the one-side limits

$$\lim_{x \rightarrow 0^+} \frac{f(x)}{x} = \lim_{x \rightarrow 0^+} \frac{x^2}{x} = 0 \quad \text{and} \quad \lim_{x \rightarrow 0^-} \frac{f(x)}{x} = \lim_{x \rightarrow 0^-} \frac{x^3}{x} = 0$$

\Rightarrow The slope of the graph of f at 0 is 0.

The equation of the tangent line is

$$y - f(0) = 0(x - 0) \Rightarrow y = 0.$$

Exercise 3.2

- 1** Find the equation of the tangent line to the graph of the function at the indicated point.
- a** $f(x) = x^2$; (1, 1) **b** $f(x) = 4x^2 - 3x - 5$; (-2, 17)
- c** $f(x) = x^3 + 1$; (-1, 0) **d** $f(x) = (x-1)^{\frac{1}{3}}$; (1, 0)
- e** $f(x) = \frac{1}{\sqrt{x}}$; (1, 1)
- 2** Let $f(x) = \begin{cases} x, & \text{if } x > 3 \\ x^2 - 6, & \text{if } x \leq 3 \end{cases}$. Find the equation of the line tangent to the graph of f at each of the following points.
- a** (0, -6) **b** (-2, -2) **c** (1, -5) **d** (3, 3) **e** (4, 4)
- 3** Let $f(x) = x^3 - 3x$, find the values of x at which the slope of the tangent line is 0.
- 4** Let $f(x) = x^3 + x^2 - x + 1$; find the set of values of x such that the slope is positive.
- 5** If the graphs of the functions f and g given by $f(x) = 4 - x^2$ and $g(x) = x^3 - 8x$ have the same slope, determine the values of x .
- 6** Let $f(x) = x^3 - x^2 - x + 1$; find the equation of the tangent line at the point where the graph crosses
- a** the x -axis **b** the y -axis **c** the graph of $y = 1 - x^2$

The derivative as a function

ACTIVITY 3.2



For each of the following functions, find the set of values of x_0 such that $f'(x_0)$ exists.

- 1** $f(x) = x^2$ **2** $f(x) = |x|$ **3** $f(x) = \begin{cases} x^2, & \text{if } x < 2 \\ 4x - 4, & \text{if } x \geq 2 \end{cases}$

From **Activity 3.2** you observed that there are functions that are differentiable at all numbers in their domain and there are functions that are not differentiable at some numbers in their domain. At this level we give the definition of the function f' as follows and determine the interval on which f' is defined.

Definition 3.6

f' is the function whose domain is the set of numbers at which f is differentiable and whose value at any such number x is given by

$$f'(x) = \lim_{t \rightarrow x} \frac{f(t) - f(x)}{t - x}.$$

Here we say $f'(x)$ is the derivative of f with respect to x . We consider t as a variable and x as a constant.

Example 13 Find the derivatives of each of the following functions with respect to x .

a $f(x) = x^2$ **b** $f(x) = \sqrt{x}; x > 0$ **c** $f(x) = \frac{2x-1}{x+4}; x \neq -4$

Solution Using **Definition 3.6** of $f'(x)$ we have,

a $f'(x) = \lim_{t \rightarrow x} \frac{t^2 - x^2}{t - x} = \lim_{t \rightarrow x} (t + x) = 2x$

b $f'(x) = \lim_{t \rightarrow x} \frac{\sqrt{t} - \sqrt{x}}{t - x} \times \frac{\sqrt{t} + \sqrt{x}}{\sqrt{t} + \sqrt{x}} = \lim_{t \rightarrow x} \frac{1}{\sqrt{t} + \sqrt{x}} = \frac{1}{2\sqrt{x}}$

c $f'(x) = \lim_{t \rightarrow x} \frac{\frac{2t-1}{t+4} - \frac{2x-1}{x+4}}{t - x} = \lim_{t \rightarrow x} \frac{2xt - x + 8t - 4 - (2tx - t + 8x - 4)}{(t-x)(t+4)(x+4)}$
 $= \lim_{t \rightarrow x} \frac{9t - 9x}{(t-x)(t+4)(x+4)} = \lim_{t \rightarrow x} \frac{9}{(t+4)(x+4)} = \frac{9}{(x+4)^2}$.

The different notations for the derivative

Recall the functional notation and the delta notation for the gradient of a graph at a point. The following are some other notations for the derivatives.

If $y = f(x)$, then $f'(x) = \frac{dy}{dx}, \frac{d}{dx} f(x), D(f(x))$

Using these notations, we have

$$f'(x_0) = \left. \frac{dy}{dx} \right|_{x=x_0} = \left. \frac{d}{dx} f(x) \right|_{x=x_0} = D(f(x_0))$$

Example 14 Find the derivative of $f(x) = \frac{1}{x}$.

Solution $f'(x) = \lim_{h \rightarrow 0} \frac{f(x+h) - f(x)}{h} = \lim_{h \rightarrow 0} \frac{\frac{1}{x+h} - \frac{1}{x}}{h} = \lim_{h \rightarrow 0} \frac{x - (x+h)}{xh(x+h)}$
 $= \lim_{h \rightarrow 0} \frac{-h}{xh(x+h)} = -\lim_{h \rightarrow 0} \frac{1}{x(x+h)} = -\frac{1}{x^2}$

Example 15 Let $y = x^4$, then $\frac{dy}{dx} = \lim_{t \rightarrow x} \frac{t^4 - x^4}{t - x} = \lim_{t \rightarrow x} \frac{(t^2 - x^2)(t^2 + x^2)}{t - x}$
 $= \lim_{t \rightarrow x} (t + x)(t^2 + x^2)$
 $= (x + x)(x^2 + x^2) = 2x(2x^2) = 4x^3$

Example 16 Let $f(x) = \frac{x}{x^2 + 1}$, then

$$\begin{aligned} D(f(x)) &= \frac{d}{dx} f(x) = f'(x) = \lim_{t \rightarrow x} \frac{\frac{t}{t^2 + 1} - \frac{x}{x^2 + 1}}{t - x} = \lim_{t \rightarrow x} \frac{tx^2 + t - xt^2 - x}{(t^2 + 1)(x^2 + 1)(t - x)} \\ &= \lim_{t \rightarrow x} \frac{tx(x - t) + (t - x)}{(t^2 + 1)(x^2 + 1)(t - x)} = \lim_{t \rightarrow x} \frac{-tx + 1}{(t^2 + 1)(x^2 + 1)} = \frac{-x^2 + 1}{(x^2 + 1)^2} = \frac{1 - x^2}{(x^2 + 1)^2} \end{aligned}$$

Exercise 3.3

Using **Definition 3.6**, find the derivatives of the following functions with respect to x .

- | | | |
|---|--|-----------------------------------|
| 1 $f(x) = x$ | 2 $f(x) = 2x - 5$ | 3 $f(x) = x^2 + 4x - 5$ |
| 4 $f(x) = \frac{1}{x}; x \neq 0$ | 5 $f(x) = \sqrt{x}$ | 6 $f(x) = x^3 - 3$ |
| 7 $f(x) = (3x - 2)^2$ | 8 $f(x) = x^2(2 + x)$ | 9 $f(x) = 8 - \sqrt[3]{x}$ |
| 10 $f(x) = \frac{x + 2}{3 - 2x}; x \neq \frac{3}{2}$ | 11 $f(x) = \left(x - \frac{3}{x}\right)^2; x \neq 0$ | |
| 12 $f(x) = \frac{4x^2 - 5x^3}{x^2}; x \neq 0$ | 13 $f(x) = 2x - 5 + \frac{x^2}{7} + x^5$ | |
| 14 $f(x) = \left(x + \frac{1}{x^2}\right)^3; x \neq 0$ | 15 $f(x) = \sqrt[3]{x} + x - \frac{1}{\sqrt{x}}; x > 0$ | |

3.1.4 Differentiability on an Interval

Definition 3.7

- If I is an open interval, then we say that a function f is differentiable on I , if f is differentiable at each point in I .
- If I is a closed interval $[a, b]$ with $a < b$, then we say that f is differentiable on I if f is differentiable on (a, b) and if the one side limits $\lim_{x \rightarrow a^+} \frac{f(x) - f(a)}{x - a}$ and

$$\lim_{x \rightarrow b^-} \frac{f(x) - f(b)}{x - b} \text{ both exist.}$$

Example 17 Let $f(x) = |x - 3|$.

- Is f differentiable at $x = 3$?
- Find the interval(s) on which f is differentiable.

Solution

a $f'(3) = \lim_{x \rightarrow 3} \frac{|x - 3| - |3 - 3|}{x - 3} = \lim_{x \rightarrow 3} \frac{|x - 3|}{x - 3}$

But, $\lim_{x \rightarrow 3^+} \frac{|x - 3|}{x - 3} = 1$ and $\lim_{x \rightarrow 3^-} \frac{|x - 3|}{x - 3} = -1 \Rightarrow f'(3)$ doesn't exist.

Therefore, f is not differentiable at 3.

b Since both $\lim_{x \rightarrow 3^-} \frac{f(x) - f(3)}{x - 3}$ and $\lim_{x \rightarrow 3^+} \frac{f(x) - f(3)}{x - 3}$ exist, f is differentiable on $(-\infty, 3]$ and $[3, \infty)$.

$f'(x) = 1$ for all $x \geq 3$ and $f'(x) = -1$ for all $x \leq 3$.

Example 18 Let $f(x) = \sqrt{1 - x^2}$. Find the largest interval on which f is differentiable.

Solution $f'(x) = \lim_{t \rightarrow x} \frac{\sqrt{1 - t^2} - \sqrt{1 - x^2}}{t - x} = \lim_{t \rightarrow x} \frac{1 - t^2 - (1 - x^2)}{(t - x)(\sqrt{1 - t^2} + \sqrt{1 - x^2})}$. *Why? Explain!*

$$= \lim_{t \rightarrow x} \frac{x^2 - t^2}{(t - x)(\sqrt{1 - t^2} + \sqrt{1 - x^2})} = \lim_{t \rightarrow x} \frac{(x - t)(x + t)}{-(x - t)(\sqrt{1 - t^2} + \sqrt{1 - x^2})}$$

$$= - \lim_{t \rightarrow x} \frac{(x + t)}{\sqrt{1 - t^2} + \sqrt{1 - x^2}} = - \frac{2x}{2\sqrt{1 - x^2}} = \frac{-x}{\sqrt{1 - x^2}}$$

Notice that the domain of $f'(x) = -\frac{x}{\sqrt{1 - x^2}}$ is $(-1, 1) \Rightarrow f$ is differentiable on $(-1, 1)$.

Definition 3.8

1 A function f is differentiable on $[a, \infty)$ if f is differentiable on (a, ∞) and the one side limit

$$\lim_{x \rightarrow a^+} \frac{f(x) - f(a)}{x - a} \text{ exists.}$$

2 A function f is differentiable on $(-\infty, a]$, if f is differentiable on $(-\infty, a)$ and the one side limit

$$\lim_{x \rightarrow a^-} \frac{f(x) - f(a)}{x - a} \text{ exists.}$$

Example 19 The absolute value function $f(x) = |x|$ is differentiable on $(-\infty, 0]$ and on $[0, \infty)$.

Example 20 Find the largest interval on which $f(x) = \frac{1}{3-2x}$ is differentiable.

Solution

$$f'(x) = \lim_{t \rightarrow x} \frac{f(t) - f(x)}{t - x} = \lim_{t \rightarrow x} \frac{\frac{1}{3-2t} - \frac{1}{3-2x}}{t - x} = \lim_{t \rightarrow x} \frac{3-2x-3+2t}{(t-x)(3-2t)(3-2x)}$$

$$= \lim_{t \rightarrow x} \frac{2(t-x)}{(t-x)(3-2t)(3-2x)} = \lim_{t \rightarrow x} \frac{2}{(3-2t)(3-2x)} = \frac{2}{(3-2x)^2}$$

$\Rightarrow f$ is differentiable on $\left(-\infty, \frac{3}{2}\right)$ and on $\left(\frac{3}{2}, \infty\right)$.

Exercise 3.4

Determine the intervals on which each of the following functions is differentiable.

- | | | |
|--|------------------------------------|-------------------------------|
| 1 $f(x) = 3x - 5$ | 2 $f(x) = x^2 + 7x + 6$ | 3 $f(x) = \frac{1}{x}$ |
| 4 $f(x) = \sqrt{x-2}$ | 5 $f(x) = \sqrt{9-4x^2}$ | 6 $f(x) = x-5 $ |
| 7 $f(x) = 2x-3 $ | 8 $f(x) = x + x-1 $ | 9 $f(x) = x x $ |
| 10 $f(x) = \begin{cases} x, & \text{if } x > 1 \\ 2-x^2, & \text{if } x \leq 1 \end{cases}$ | 11 $f(x) = \frac{x-1}{3-x}$ | |

3.2

DERIVATIVES OF SOME FUNCTIONS

Differentiation of power, simple trigonometric, exponential and logarithmic functions

ACTIVITY 3.3

- 1** Using your knowledge of limits, evaluate each of the following limits.

a $\lim_{t \rightarrow x} \frac{t^3 - x^3}{t - x}$	b $\lim_{t \rightarrow x} \frac{t^{\frac{1}{3}} - x^{\frac{1}{3}}}{t - x}$	c $\lim_{h \rightarrow 0} \frac{\cos h - 1}{h}$
d $\lim_{h \rightarrow 0} \frac{e^h - 1}{h}$	e $\lim_{h \rightarrow 0} \frac{a^h - 1}{h}$, where $a > 0$.	

- 2** Using **Definition 3.6**, find the derivatives of each of the following power functions.

a $f(x) = x$	b $f(x) = x^2$	c $f(x) = x^4$	d $f(x) = x^{-1}$
e $f(x) = x^{-5}$	f $f(x) = x^{\frac{1}{2}}$	g $f(x) = x^{\frac{-3}{2}}$	h $f(x) = x^{\frac{-1}{3}}$



The derivatives of the power functions in the **Activity** can be summarized as follows:

Function $f(x)$	Derivative $f'(x)$
x	1
x^2	$2x$
x^4	$4x^3$
x^{-1}	$-x^{-2}$
x^{-5}	$-5x^{-6}$
$\frac{1}{x^2}$	$\frac{1}{2}x^{-\frac{3}{2}}$
$x^{-\frac{3}{2}}$	$-\frac{3}{2}x^{-\frac{5}{2}}$
$\frac{-1}{x^3}$	$-\frac{1}{3}x^{-\frac{4}{3}}$

From this table one can see that if $f(x) = x^n$, then $f'(x) = nx^{n-1}$.

Derivative of a power function

Here, we consider the derivative of $f(x) = x^r$ with respect to x when r is a real number.

Theorem 3.1 Power rule for differentiation

Let $f(x) = x^n$, where n is a positive integer. Then $f'(x) = nx^{n-1}$

Proof:

Let $f(x) = x^n$. Then, using the **Definition of derivative**, we obtain,

$$\begin{aligned} f'(x) &= \lim_{t \rightarrow x} \frac{f(t) - f(x)}{t - x} = \lim_{t \rightarrow x} \frac{t^n - x^n}{t - x} \\ &= \lim_{t \rightarrow x} \frac{(t - x)(t^{n-1} + xt^{n-2} + x^2t^{n-3} + \dots + x^{n-2}t + x^{n-1})}{t - x} \\ &= \lim_{t \rightarrow x} (t^{n-1} + xt^{n-2} + x^2t^{n-3} + \dots + x^{n-2}t + x^{n-1}) \\ &= x^{n-1} + x^{n-1} + x^{n-1} + \dots + x^{n-1} + x^{n-1} = nx^{n-1}. \end{aligned}$$

Example 1 Find the derivatives of each of the following functions

a $f(x) = x^4$ **b** $f(x) = x^{10}$ **c** $f(x) = x^{95}$ **d** $f(x) = x^{102}$

Solution Using **Theorem 3.1**, we have

a $f'(x) = (x^4)' = 4x^3$ **b** $f'(x) = (x^{10})' = 10x^9$
c $f'(x) = 95x^{94}$ **d** $f'(x) = 102x^{101}$

Corollary 3.1

If $f(x) = x^{-n}$, where n is a positive integer, then $f'(x) = -n x^{-(n+1)}$.

Proof:

$$\begin{aligned}
 f(x) &= \lim_{t \rightarrow x} \left(\frac{\frac{1}{t^n} - \frac{1}{x^n}}{t - x} \right) = \lim_{t \rightarrow x} \frac{x^n - t^n}{(t - x)t^n x^n} = \lim_{t \rightarrow x} \frac{x^n - t^n}{t - x} \times \lim_{t \rightarrow x} \frac{1}{t^n x^n} \\
 &= (-nx^{n-1}) \left(\frac{1}{x^{2n}} \right). \text{ Why? Explain!} \\
 &= -nx^{-1-n} = -nx^{-(n+1)}
 \end{aligned}$$

Example 2 Let $f(x) = x^{-7}$, evaluate

a $f'(1)$ **b** $f'\left(-\frac{1}{2}\right)$ **c** $f'(c)$

Solution By **Corollary 3.1**, $f'(x) = (x^{-7})' = -7(x^{-8})$. Hence,

a $f'(1) = -7$

b $f'\left(-\frac{1}{2}\right) = -7\left(-\frac{1}{2}\right)^{-8} = -7((-2)^8) = -7(-2)^8 = -1792$

c $f'(c) = -7c^{-8}$.

Corollary 3.2Let $f(x) = cx^n$, then $f'(x) = cnx^{n-1}$; where n is any non-zero integer.**Proof:**

$$\begin{aligned}
 f(x) = cx^n \Rightarrow f'(x) &= \lim_{t \rightarrow x} \frac{f(t) - f(x)}{t - x} = \lim_{t \rightarrow x} \frac{ct^n - cx^n}{t - x} = \lim_{t \rightarrow x} c \frac{(t^n - x^n)}{t - x} \\
 &= c \lim_{t \rightarrow x} \frac{t^n - x^n}{t - x} = c f'(x) = cnx^{n-1}
 \end{aligned}$$

Example 3 Find the derivative of each of the following functions:

a $f(x) = 4x^7$ **b** $f(x) = -11x^6$ **c** $f(x) = \frac{6}{x^{10}}$ **d** $f(x) = \frac{-\pi}{x^{13}}$

Solution By **Corollary 3.2**, we have

a $f'(x) = 4(x^7)' = 4(7x^6) = 28x^6$

b $f'(x) = (-11x^6)' = -11(x^6)' = -11(6x^5) = -66x^5$

c $f'(x) = \left(\frac{6}{x^{10}}\right)' = 6(x^{-10})' = 6(-10x^{-11}) = -60x^{-11}$

d $f'(x) = \left(\frac{-\pi}{x^{13}}\right)' = -\pi(-13x^{-14}) = 13\pi x^{-14}$.

Theorem 3.2 Derivatives of power functions

Let $f(x) = x^r$; where r is a real number. Then, $f'(x) = rx^{r-1}$.

Example 4 Find the derivatives of each of the following functions

- a** $f(x) = x^{\frac{1}{2}}$ **b** $f(x) = x^{\frac{3}{5}}$ **c** $f(x) = x^{\pi}$
d $f(x) = x^{-4.05}$ **e** $f(x) = x^{\sqrt{2}}$ **f** $f(x) = x^{e-3}$

Solution By using **Theorem 3.2**, we obtain,

- a** $f'(x) = \frac{1}{2}x^{\frac{1}{2}-1} = \frac{1}{2}x^{-\frac{1}{2}} = \frac{1}{2x^{\frac{1}{2}}} = \frac{1}{2\sqrt{x}}$ **b** $f'(x) = \frac{3}{5}x^{\frac{3}{5}-1} = \frac{3}{5x^{\frac{2}{5}}}$
c $f'(x) = \pi x^{\pi-1}$ **d** $f'(x) = -4.05x^{-5.05}$
e $f'(x) = \sqrt{2}x^{\sqrt{2}-1}$ **f** $f'(x) = (e-3)x^{e-4}$

Exercise 3.5

1 Find the derivatives of each of the following functions with respect to x .

- a** $f(x) = x^3$ **b** $f(x) = x^5$ **c** $f(x) = x^{11}$
d $f(x) = x^{-7}$ **e** $f(x) = x^{-10}$ **f** $f(x) = x^{\frac{3}{4}}$
g $f(x) = x^{\frac{-5}{3}}$ **h** $f(x) = x^3\sqrt{x}$ **i** $f(x) = x^{\frac{3}{2}}\sqrt[3]{x^2}$
j $f(x) = x^{1-\pi}$

2 Let $f(x) = (\sqrt[3]{x})x^2$, find

- a** $f'(0)$ **b** $f'(1)$ **c** $f'(8)$

3 Let $f(x) = x^{\frac{4}{5}}$

- a** If $f'(a) = -\frac{4}{5}$, find the equation of the line tangent to the graph of f at $(a, f(a))$.
b If f has a vertical tangent at $(a, f(a))$, find the value of a .

Derivatives of simple trigonometric functions

Theorem 3.3 Derivatives of sine and cosine functions

- 1** If $f(x) = \sin x$, then $f'(x) = \cos x$. **2** If $f(x) = \cos x$, then $f'(x) = -\sin x$.

Proof

$$\begin{aligned}
 \mathbf{1} \quad f(x) = \sin x &\Rightarrow f'(x) = \lim_{h \rightarrow 0} \frac{f(x+h) - f(x)}{h} = \lim_{h \rightarrow 0} \frac{\sin(x+h) - \sin x}{h} \\
 &\Rightarrow f'(x) = \lim_{h \rightarrow 0} \frac{\sin x \cos h + \cos x \sin h - \sin x}{h} = \lim_{h \rightarrow 0} \left(\frac{\sin x(\cos h - 1)}{h} + \frac{\cos x \sin h}{h} \right) \\
 &= \sin x \lim_{h \rightarrow 0} \frac{\cos h - 1}{h} + \cos x \lim_{h \rightarrow 0} \frac{\sin h}{h} = 0 + (\cos x) \times 1 = \cos x.
 \end{aligned}$$

$$\begin{aligned}
 \mathbf{2} \quad f(x) = \cos x &\Rightarrow f'(x) = \lim_{h \rightarrow 0} \frac{f(x+h) - f(x)}{h} = \lim_{h \rightarrow 0} \frac{\cos(x+h) - \cos x}{h} \\
 &= \lim_{h \rightarrow 0} \frac{\cos x \cos h - \sin x \sin h - \cos x}{h} = \lim_{h \rightarrow 0} \left(\frac{(\cos x(\cos h - 1))}{h} - \sin x \frac{\sin h}{h} \right) \\
 &= \cos x \lim_{h \rightarrow 0} \frac{\cos h - 1}{h} - \sin x \lim_{h \rightarrow 0} \frac{\sin h}{h} = (\cos x) \times 0 - (\sin x) \times 1 = -\sin x
 \end{aligned}$$

Exercise 3.6

- 1** Find the derivatives of each of the following functions with respect to the appropriate variable.
- a** $f(x) = -\sin x$ **b** $g(\theta) = -\cos \theta$
c $f(x) = \sec x$ **d** $g(t) = \csc t$
- 2** Find the equation of the tangent line to the graph of f at the given point.
- a** $f(x) = \sin x; \left(\frac{\pi}{4}, \frac{\sqrt{2}}{2}\right)$ **b** $g(x) = \cos x; \left(\frac{\pi}{2}, 0\right)$
c $h(x) = \tan x; \left(\frac{\pi}{4}, 1\right)$
- 3** If the line tangent to the graph of $f(x) = \sin x$ at $x = a$ has y -intercept $\frac{\sqrt{3}}{6} - \frac{\pi}{3}$, find the x -intercept of the line when $0 < a < \frac{\pi}{2}$.

Derivatives of exponential function**Theorem 3.4 Derivatives of exponential functions**

If $f(x) = a^x; a > 0$, then $f'(x) = a^x \ln a$.

$$\text{If } f(x) = e^x, \text{ then } f'(x) = \lim_{t \rightarrow x} \frac{e^t - e^x}{t - x}.$$

Let $h = t - x$. Then as $t \rightarrow x$, $h \rightarrow 0$.

$$\text{Thus, } f'(x) = \lim_{h \rightarrow 0} \frac{e^{x+h} - e^x}{h} = \lim_{h \rightarrow 0} e^x \left(\frac{e^h - 1}{h} \right) = e^x \lim_{h \rightarrow 0} \frac{e^h - 1}{h} = e^x \ln e = e^x$$

Notice also that $f'(x) = \lim_{h \rightarrow 0} \frac{f(x+h) - f(x)}{h}$. You will use this fact for the proof.

Proof:

$$\text{Let } f(x) = a^x.$$

$$\Rightarrow f'(x) = \lim_{h \rightarrow 0} \frac{f(x+h) - f(x)}{h} = \lim_{h \rightarrow 0} \frac{a^x(a^h - 1)}{h} = a^x \lim_{h \rightarrow 0} \frac{a^h - 1}{h} = a^x \ln a$$

Example 5 Find the derivative of each of the following exponential functions.

- a** $f(x) = 4^x$ **b** $f(x) = \sqrt{5^x}$ **c** $f(x) = \pi^x$
d $f(x) = e^{x+3}$ **e** $f(x) = \sqrt[3]{e^x}$ **f** $f(x) = 2^{3x+5}$

Solution

- a** $f(x) = 4^x \Rightarrow f'(x) = 4^x \ln 4$
b $f(x) = \sqrt{5^x} \Rightarrow f'(x) = \sqrt{5^x} \ln \sqrt{5} = \frac{5^{\frac{1}{2}x}}{2} \ln 5$
c $f(x) = \pi^x \Rightarrow f'(x) = \pi^x \ln \pi$
d $f(x) = e^{x+3} \Rightarrow f(x) = e^3 \cdot e^x \Rightarrow f'(x) = e^3 e^x = e^{x+3}$
e $f(x) = \sqrt[3]{e^x} \Rightarrow f'(x) = \sqrt[3]{e^x} \ln \sqrt[3]{e} = \frac{1}{3} \sqrt[3]{e^x} \ln e = \frac{1}{3} e^{\frac{x}{3}}$
f $f(x) = 2^{3x+5} \Rightarrow f'(x) = 2^5 \times 8^x \ln 8$
 $\Rightarrow f'(x) = 2^5 \times 2^{3x} (3 \ln 2) \Rightarrow f'(x) = 96 (2^{3x}) \ln 2.$

Derivatives of logarithmic functions

Theorem 3.5 Derivatives of logarithmic functions

If $f(x) = \ln x$, $x > 0$, then $f'(x) = \frac{1}{x}$.

Proof:

$$\text{Let } f(x) = \ln x.$$

$$\Rightarrow f'(x) = \lim_{h \rightarrow 0} \frac{f(x+h) - f(x)}{h} = \lim_{h \rightarrow 0} \frac{\ln(x+h) - \ln x}{h} = \lim_{h \rightarrow 0} \frac{\ln\left(\frac{x+h}{x}\right)}{h} = \lim_{h \rightarrow 0} \frac{1}{h} \ln\left(1 + \frac{h}{x}\right)$$

$$\Rightarrow \lim_{h \rightarrow 0} \ln\left(1 + \frac{h}{x}\right)^{\frac{1}{h}} = \ln\left(\lim_{h \rightarrow 0} \left(1 + \frac{h}{x}\right)^{\frac{1}{h}}\right) = \ln\left(e^{\frac{1}{x}}\right) = \frac{1}{x}.$$

Corollary 3.3

If $f(x) = \log_a x$, $x > 0$, $a > 0$ and $a \neq 1$, then $f'(x) = \frac{1}{x \ln a}$.

Proof:

$$f(x) = \log_a x = \frac{\ln x}{\ln a} \Rightarrow f'(x) = \frac{1}{\ln a} (\ln x)' = \frac{1}{\ln a} \times \frac{1}{x} = \frac{1}{x \ln a}.$$

Example 6 Find the derivatives of each of the following logarithmic functions

a $f(x) = \log_2 x$

b $f(x) = \log x$

c $f(x) = \log_{\frac{1}{5}} x$

d $f(x) = \log(x^3)$

e $f(x) = \ln \sqrt[5]{x}$

f $f(x) = \log_5 \sqrt{x^3}$

Solution

a $f(x) = \log_2 x \Rightarrow f'(x) = \frac{1}{x \ln 2}$

b $f(x) = \log x \Rightarrow f'(x) = \frac{1}{x \ln 10}$

c $f(x) = \log_{\frac{1}{5}} x \Rightarrow f'(x) = \frac{1}{x \ln\left(\frac{1}{5}\right)} = -\frac{1}{x \ln 5}$

d $f(x) = \log(x^3) \Rightarrow f(x) = 3 \log x \Rightarrow f'(x) = \frac{3}{x \ln 10}$

e $f(x) = \ln \sqrt[5]{x} \Rightarrow f(x) = \frac{1}{5} \ln x \Rightarrow f'(x) = \frac{1}{5x}$

f $f(x) = \log_5 \sqrt{x^3} \Rightarrow f(x) = \frac{3}{2} \log_5 x \Rightarrow f'(x) = \frac{3}{2x \ln 5}$

Exercise 3.7

1 Differentiate each of the following functions with respect to the appropriate variable.

a $f(x) = 3^x$

b $f(x) = \sqrt{3^x}$

c $f(x) = 49^x$

d $f(x) = (\pi + 1)^x$

e $f(x) = e^{4x}$

f $f(x) = \sqrt{e^{3x}}$

g $h(x) = 3^x \times 3^x \times 2^{2x}$

h $f(x) = \log_7 x$

i $h(x) = \ln(4x)$

j $f(x) = \log_{0.125}(6x)$

k $h(x) = \ln\left(x^{\frac{3}{5}}\right)$

- 2 Find the equation of the line tangent to the graph of $y = e^x$ at $(1, e)$.
- 3 Find the equation of the line tangent to the graph of $f(x) = \ln x$ at $\left(\frac{1}{e^3}, -3\right)$.
- 4 Suppose $f(x) = 2^x$. What happens to the gradient of the graph of $f(x)$ as $x \rightarrow \infty$ and as $x \rightarrow -\infty$?
- 5 Let $g(x) = \log_2 x$. Decide the nature of the gradient of $g(x)$ as $x \rightarrow 0^+$ and as $x \rightarrow \infty$.

3.3 DERIVATIVES OF COMBINATIONS AND COMPOSITIONS OF FUNCTIONS

ACTIVITY 3.4



- 1 For each of the following functions f and g , evaluate
 - a $f(x) + g(x)$ b $f(x) - g(x)$ c $f(x)g(x)$ d $\frac{f(x)}{g(x)}$
 - i $f(x) = 2x + 1$ and $g(x) = 3x^2 + 5x + 1$
 - ii $f(x) = 4x^2 + 1$ and $g(x) = \frac{2x-1}{4x+2}$
 - iii $f(x) = e^x$ and $g(x) = \sin x$
 - iv $f(x) = \log(x^2 + 1)$ and $g(x) = \cos\left(\frac{1}{x}\right)$.
 - v $f(x) = 3^{x^2+1}$ and $g(x) = \tan x$.
- 2 Using the **Definition of the derivative of a function**, differentiate each of the following functions.
 - a $f(x) = 4x + 5$ b $f(x) = 4x^2 + 3x + 1$
 - c $f(x) = \sqrt{x} + \frac{1}{x}$ d $f(x) = \frac{3x-1}{4x+2}$
- 3 Given the functions $f(x) = \frac{1}{x}$ and $g(x) = \sqrt{x}$, decide whether or not each of the following equalities is correct.
 - a $(f(x) + g(x))' = f'(x) + g'(x)$ b $(f(x) - g(x))' = f'(x) - g'(x)$
 - c $(f(x)g(x))' = f'(x)g'(x)$ d $\left(\frac{f(x)}{g(x)}\right)' = \frac{f'(x)}{g'(x)}$

- 4** Given the functions $f(x) = x^2 - 1$, $g(x) = 3^x$, $k(x) = \log_2 x$ and $h(x) = \sin x$, evaluate
- | | | | |
|----------|-------------------------|----------|--|
| a | $f'(x) + g'(x)$ | b | $h'(x) - k'(x)$ |
| c | $f'(x)g(x) + g'(x)f(x)$ | d | $\frac{h'(x)k(x) - h(x)k'(x)}{(k(x))^2}$ |
- 5** Let $f(x) = |x|$
- | | | | |
|----------|-------------------------|----------|-----------------------------|
| a | Is f continuous at 0? | b | Is f differentiable at 0? |
|----------|-------------------------|----------|-----------------------------|
- 6** Let $f(x) = \begin{cases} x^2, & \text{if } x \leq 2 \\ 8 - 2x, & \text{if } x > 2 \end{cases}$. Sketch the graph of f and discuss the continuity and differentiability of f at
- | | | | | | |
|----------|---|----------|---|----------|---|
| a | 2 | b | 1 | c | 3 |
|----------|---|----------|---|----------|---|

In **Activity 3.4 Problems 5** and **6**, you noticed that there are functions that are continuous but not differentiable at a given point. The following **Theorem** states that the condition for a function being differentiable at a given point is stronger than the condition for being continuous at that point.

Theorem 3.6

If f is differentiable at a , then f is continuous at a .

Proof:

Suppose f is differentiable at a . Then, $f'(a) = \lim_{x \rightarrow a} \frac{f(x) - f(a)}{x - a}$ exists.

Observe that, for $x \neq a$, $f(x) - f(a) = \left(\frac{f(x) - f(a)}{x - a} \right)(x - a)$

$$\begin{aligned} \text{Hence, } \lim_{x \rightarrow a} (f(x) - f(a)) &= \lim_{x \rightarrow a} \left(\frac{f(x) - f(a)}{x - a} \right)(x - a) = \lim_{x \rightarrow a} \frac{f(x) - f(a)}{x - a} \cdot \lim_{x \rightarrow a} (x - a) \\ &= f'(a) \times 0 = 0 \end{aligned}$$

$$\Rightarrow \lim_{x \rightarrow a} (f(x) - f(a)) = 0 \Rightarrow \lim_{x \rightarrow a} f(x) - \lim_{x \rightarrow a} f(a) = 0$$

$$\Rightarrow \lim_{x \rightarrow a} f(x) = f(a) \Rightarrow f \text{ is continuous at } a.$$

The following example shows that the converse of this theorem is not true.

Example 1 Show that each of the following functions is continuous but not differentiable at the indicated numbers.

- | | | | |
|----------|---|----------|---------------------------------------|
| a | $f(x) = x $; $x = 0$ | b | $f(x) = 3x - 1 $; $x = \frac{1}{3}$ |
| c | $f(x) = \begin{cases} \sin x, & \text{if } x > 0 \\ -x, & \text{if } x \leq 0 \end{cases}$ at $x = 0$ | | |

Solution

a $\lim_{x \rightarrow 0^+} f(x) = \lim_{x \rightarrow 0} |x| = 0 = f(0) \Rightarrow f$ is continuous at $(0, 0)$.

$$f'(0) = \lim_{x \rightarrow 0} \frac{f(x) - f(0)}{x - 0} = \lim_{x \rightarrow 0} \frac{|x|}{x}$$

Here, we have $\lim_{x \rightarrow 0^+} \frac{|x|}{x} = \lim_{x \rightarrow 0^+} \frac{x}{x}$. But $\lim_{x \rightarrow 0^-} \frac{|x|}{x} = \lim_{x \rightarrow 0^-} \frac{-x}{x} = -1$

$$\Rightarrow \lim_{x \rightarrow 0} \frac{f(x) - f(0)}{x - 0} \text{ doesn't exist.}$$

Hence, f is not differentiable at $x = 0$.

b $f(x) = |3x - 1|$

$$\lim_{x \rightarrow \frac{1}{3}} f(x) = \lim_{x \rightarrow \frac{1}{3}} |3x - 1| = 0 = f\left(\frac{1}{3}\right) \Rightarrow f \text{ is continuous at } x = \frac{1}{3}$$

$$f'\left(\frac{1}{3}\right) = \lim_{x \rightarrow \frac{1}{3}} \frac{f(x) - f\left(\frac{1}{3}\right)}{x - \frac{1}{3}} = \lim_{x \rightarrow \frac{1}{3}} \frac{|3x - 1| - 0}{x - \frac{1}{3}} \text{ Here, } \lim_{x \rightarrow \left(\frac{1}{3}\right)^+} \frac{|3x - 1|}{x - \frac{1}{3}} = 3.$$

$$\text{But } \lim_{x \rightarrow \left(\frac{1}{3}\right)^-} \frac{|3x - 1|}{x - \frac{1}{3}} = -3. \Rightarrow f \text{ is not differentiable at } x = \frac{1}{3}.$$

c $\lim_{x \rightarrow 0^+} f(x) = \lim_{x \rightarrow 0^+} \sin x = 0$ and Also, $f(0) = 0$

Thus, f is continuous at $x = 0$.

$$f(x) = \begin{cases} \cos x, & \text{if } x > 0 \\ -1, & \text{if } x < 0 \end{cases} \text{ . But } f'(0) \text{ doesn't exist.}$$

$\Rightarrow f$ is not differentiable at $x = 0$

What conclusion can you make about differentiability at a point where a graph has a sharp point?

3.3.1 Derivative of a Sum or Difference of Two Functions

Theorem 3.7 Derivative of a sum or difference of two functions

If f and g are differentiable at x_0 , then $f + g$ and $f - g$ are also differentiable at x_0 , and their derivatives are given as follows:

1 $(f + g)'(x_0) = f'(x_0) + g'(x_0) \dots \dots \dots$ *The sum rule.*

2 $(f - g)'(x_0) = f'(x_0) - g'(x_0) \dots \dots \dots$ *The difference rule.*

Proof:

$$\begin{aligned}
 \mathbf{1} \quad (f+g)'(x_0) &= \lim_{x \rightarrow x_0} \frac{(f+g)(x) - (f+g)(x_0)}{x - x_0} \\
 &= \lim_{x \rightarrow x_0} \frac{f(x) + g(x) - f(x_0) - g(x_0)}{x - x_0} \\
 &= \lim_{x \rightarrow x_0} \left(\frac{f(x) - f(x_0)}{x - x_0} + \frac{g(x) - g(x_0)}{x - x_0} \right) \\
 &= \lim_{x \rightarrow x_0} \left(\frac{f(x) - f(x_0)}{x - x_0} \right) + \lim_{x \rightarrow x_0} \left(\frac{g(x) - g(x_0)}{x - x_0} \right) \\
 &= f'(x_0) - g'(x_0)
 \end{aligned}$$

2 The proof follows a similar argument to **1** above.

Example 2 Let $f(x) = 4x^3 + \sin x$. Evaluate

$$\mathbf{a} \quad f'(0) \qquad \mathbf{b} \quad f'\left(\frac{\pi}{4}\right)$$

Solution From the above **Theorem** we have,

$$f'(x) = (4x^3 + \sin x)' = (4x^3)' + (\sin x)' = 12x^2 + \cos x$$

$$\mathbf{a} \quad f'(0) = 12(0^2) + \cos 0 = 1$$

$$\mathbf{b} \quad f'\left(\frac{\pi}{4}\right) = 12\left(\frac{\pi}{4}\right)^2 + \cos\left(\frac{\pi}{4}\right) = 12\frac{\pi^2}{16} + \frac{\sqrt{2}}{2} = \frac{3}{4}\pi^2 + \frac{\sqrt{2}}{2} = \frac{3\pi^2 + 2\sqrt{2}}{4}$$

Example 3 Find the derivative of each of the following functions.

$$\mathbf{a} \quad f(x) = \sqrt{x} + 3^x \qquad \mathbf{b} \quad h(x) = x^{\frac{1}{3}} + \log_2 x \qquad \mathbf{c} \quad k(x) = e^x - \cos x$$

Solution

$$\mathbf{a} \quad f'(x) = (\sqrt{x})' + (3^x)' = \frac{1}{2\sqrt{x}} + 3^x \ln 3.$$

$$\mathbf{b} \quad h'(x) = \left(x^{\frac{1}{3}}\right)' + (\log_2 x)' = \frac{1}{3} x^{-\frac{2}{3}} + \frac{1}{x \ln 2} = \frac{1}{3x^{\frac{2}{3}}} + \frac{1}{x \ln 2}.$$

$$\mathbf{c} \quad k'(x) = (e^x)' - (\cos x)' = e^x - (-\sin x) = e^x + \sin x.$$

Example 4 Differentiate each of the following functions with respect to x .

$$\mathbf{a} \quad y = 2x^4 - 5x^2 + 7x - 11 \qquad \mathbf{b} \quad f(x) = \sqrt{x} + \log x - 4^x + \frac{1}{x^2}$$

Solution Using the derivative of a sum and difference

$$\begin{aligned} \mathbf{a} \quad f'(x) &= (2x^4 - 5x^2 + 7x - 11)' = (2x^4 - 5x^2)' + (7x - 11)' \\ &= (2x^4)' - (5x^2)' + (7x)' - (11)' = 8x^3 - 10x + 7. \end{aligned}$$

$$\begin{aligned} \mathbf{b} \quad f'(x) &= \left(\sqrt{x} + \log x - 4^x + \frac{1}{x^2} \right)' = \left(\sqrt{x} + \log x \right)' - \left(4^x - \frac{1}{x^2} \right)' \\ &= (\sqrt{x})' + (\log x)' - \left[(4^x)' - \left(\frac{1}{x^2} \right)' \right] = \frac{1}{2\sqrt{x}} + \frac{1}{x \ln 10} - \left(4^x \ln 4 + \frac{2}{x^3} \right) \\ &= \frac{1}{2\sqrt{x}} + \frac{1}{x \ln 10} - 4^x \ln 4 - \frac{2}{x^3} \end{aligned}$$

Corollary 3.4

If $f_1, f_2, f_3, \dots, f_n$ are differentiable at x_0 , then $\sum_{i=1}^n f_i$ is differentiable at x_0 and

$$\left(\sum_{i=1}^n f_i \right)'(x_0) = \sum_{i=1}^n f_i'(x_0).$$

Example 5 Find the derivatives of each of the following functions

$$\mathbf{a} \quad f(x) = 4x^3 + 5x^2 - 11x + 12 \qquad \mathbf{b} \quad g(x) = 16x^9 - 12x^8 - 9x^5 + 23$$

Solution

a

$$\begin{aligned} \frac{d}{dx} f(x) &= \frac{d}{dx} (4x^3 + 5x^2 - 11x + 12) = \frac{d}{dx} (4x^3) + \frac{d}{dx} (5x^2) - \frac{d}{dx} (11x) + \frac{d}{dx} (12) \\ &= 12x^2 + 10x - 11 + 0 \\ &= 12x^2 + 10x - 11. \end{aligned}$$

b

$$\begin{aligned} \frac{d}{dx} g(x) &= \frac{d}{dx} (16x^9 - 12x^8 - 9x^5 + 23) \\ &= \frac{d}{dx} (16x^9) - \frac{d}{dx} (12x^8) - \frac{d}{dx} (9x^5) + \frac{d}{dx} (23) \\ &= 144x^8 - 96x^7 - 45x^4. \end{aligned}$$

The derivative of a polynomial function

Let $f(x) = a_n x^n + a_{n-1} x^{n-1} + \dots + a_2 x^2 + a_1 x + a_0$. Then,

$$f'(x) = n a_n x^{n-1} + (n-1) a_{n-1} x^{n-2} + \dots + 2a_2 x + a_1$$

3.3.2 Derivatives of Product and Quotient of Functions

Derivatives of product of functions

ACTIVITY 3.5



1 Evaluate each of the following limits.

$$\text{a } \lim_{h \rightarrow 0} \frac{(x+h)e^{x+h} - xe^x}{h} \quad \text{b } \lim_{h \rightarrow 0} \frac{(x+h)\sin(x+h) - x\sin x}{h}$$

2 Using the **Definition of derivatives**, differentiate each of the following functions with respect to x .

$$\text{a } f(x) = xe^x \quad \text{b } f(x) = x \sin x$$

Theorem 3.8.1 The product rule

If f and g are differentiable functions at x_0 , then the product fg is differentiable at x_0 and its derivative is given as follows:

$$(fg)'(x_0) = f'(x_0)g(x_0) + g'(x_0)f(x_0).$$

Proof:

$$\begin{aligned} (fg)'(x_0) &= \lim_{x \rightarrow x_0} \frac{(fg)(x) - (fg)(x_0)}{x - x_0} = \lim_{x \rightarrow x_0} \frac{f(x)g(x) - f(x_0)g(x_0)}{x - x_0} \\ &= \lim_{x \rightarrow x_0} \frac{f(x)g(x) - f(x_0)g(x) + f(x_0)g(x) - f(x_0)g(x_0)}{x - x_0} \\ &= \lim_{x \rightarrow x_0} \frac{g(x)(f(x) - f(x_0)) + f(x_0)(g(x) - g(x_0))}{x - x_0} \\ &= \lim_{x \rightarrow x_0} g(x) \left(\frac{f(x) - f(x_0)}{x - x_0} \right) + \lim_{x \rightarrow x_0} f(x_0) \left(\frac{g(x) - g(x_0)}{x - x_0} \right) \\ &= \lim_{x \rightarrow x_0} g(x) \lim_{x \rightarrow x_0} \frac{f(x) - f(x_0)}{x - x_0} + f(x_0) \lim_{x \rightarrow x_0} \frac{g(x) - g(x_0)}{x - x_0} \\ &= g(x_0)f'(x_0) + f(x_0)g'(x_0) \end{aligned}$$

$$\text{If } y = f(x) \cdot g(x), \text{ then } \left. \frac{dy}{dx} \right|_{x=x_0} = g(x_0) \left. \frac{d}{dx} (f(x)) \right|_{x=x_0} + f(x_0) \left. \frac{d}{dx} (g(x)) \right|_{x=x_0}$$

Example 6 Let $h(x) = (x+5)(x^2+1)$. Evaluate $h'(3)$.

Solution Let $f(x) = x+5$ and $g(x) = x^2+1$.

Then, using the product rule you obtain, $h'(3) = f'(3)g(3) + g'(3)f(3)$.

But $f'(x) = 1$ so that $f'(3) = 1$ and $g'(x) = 2x$, so that $g'(3) = 6$.

Therefore, $h'(3) = 1 \times 10 + 6 \times 8 = 58$.

Example 7 Let $f(x) = x e^{x+1}$, evaluate $f'(-1)$.

Solution Let $h(x) = x$ and $k(x) = e^{x+1}$, then $f(x) = h(x)k(x)$.

Then, $h'(x) = 1$ and $k'(x) = e^{x+1}$.

$$\Rightarrow f'(-1) = h'(-1)k(-1) + k'(-1)h(-1) = 1 \times e^0 + e^0 \times (-1) = 0$$

Example 8 Let $y = e^x \sin x$, evaluate $\frac{dy}{dx}\bigg|_{x=\frac{\pi}{3}}$

Solution

$$\begin{aligned} \frac{dy}{dx}\bigg|_{x=\frac{\pi}{3}} &= \left(\sin x \frac{d}{dx}(e^x) \right)\bigg|_{x=\frac{\pi}{3}} + \left(e^x \frac{d}{dx}(\sin x) \right)\bigg|_{x=\frac{\pi}{3}} \\ &= \sin x e^x \bigg|_{x=\frac{\pi}{3}} + e^x \cos x \bigg|_{x=\frac{\pi}{3}} = \sin \frac{\pi}{3} e^{\frac{\pi}{3}} + e^{\frac{\pi}{3}} \cos \frac{\pi}{3} \\ &= \frac{\sqrt{3}}{2} e^{\frac{\pi}{3}} + e^{\frac{\pi}{3}} \times \frac{1}{2} = \frac{e^{\frac{\pi}{3}}}{2} (\sqrt{3} + 1) \end{aligned}$$

Theorem 3.8.2 The product rule

$(fg)'(x) = f'(x)g(x) + f(x)g'(x)$, for all x at which both f and g are differentiable.

Note:

✓ If $y = (fg)(x)$, then

$$\frac{dy}{dx} = g(x) \frac{d}{dx} f(x) + f(x) \frac{d}{dx} g(x)$$

Example 9 Find the derivative of each of the following functions using the product rule.

a $f(x) = x \sin x$

b $f(x) = x^2 \cos x$

c $f(x) = (x^2 - 5x + 1)e^x$

d $f(x) = \sqrt{x} \log_2 x$

Solution

a $f'(x) = (x \sin x)' = (x)' \sin x + x (\sin x)' = 1 \times \sin x + x (\cos x)$
 $= \sin x + x \cos x$

b $f'(x) = (x^2 \cos x)' = (x^2)' \cos x + x^2 (\cos x)' = 2x \cos x + x^2 (-\sin x)$
 $= 2x \cos x - x^2 \sin x$

$$\begin{aligned} \mathbf{c} \quad f'(x) &= \left((x^2 - 5x + 1) e^x \right)' = (x^2 - 5x + 1)' e^x + (e^x)' (x^2 - 5x + 1) \\ &= (2x - 5) e^x + e^x (x^2 - 5x + 1) = (x^2 - 3x - 4) e^x. \end{aligned}$$

$$\mathbf{d} \quad f'(x) = \left(\sqrt{x} \log_2 x \right)' = \frac{1}{2\sqrt{x}} \log_2 x + \frac{\sqrt{x}}{x \ln 2}$$

Example 10 Let $y = 3^x \cos x$, find $\frac{dy}{dx}$

Solution
$$\begin{aligned} \frac{dy}{dx} &= \frac{d}{dx} (3^x \cos x) = \cos x \frac{d}{dx} (3^x) + 3^x \frac{d}{dx} (\cos x) \\ &= 3^x \ln 3 \cos x - 3^x \sin x = 3^x (\ln 3 \cos x - \sin x) \end{aligned}$$

Example 11 Find the derivative of $f(x) = (x^2 + 1) (\ln x) (\sin x)$

Solution

$$\begin{aligned} f'(x) &= \frac{d}{dx} \left((x^2 + 1) (\ln x) (\sin x) \right) = (\ln x) (\sin x) \frac{d}{dx} (x^2 + 1) + (x^2 + 1) \frac{d}{dx} (\ln x \sin x) \\ &= (\ln x \sin x) 2x + (x^2 + 1) \left(\frac{1}{x} \sin x + \ln x \cos x \right). \quad (\text{Explain!}) \\ &= 2x \ln x \sin x + (x^2 + 1) \left(\frac{1}{x} \sin x + \ln x \cos x \right). \end{aligned}$$

One of the purposes of this example is to extend the product rule for finding the derivatives of the products of three or more functions such as

$$\begin{aligned} (fgh)'(x) &= (fg)'(x) h(x) + h'(x) (fg)(x) \\ &= (f'(x) g(x) + g'(x) f(x)) h(x) + h'(x) (fg)(x) \\ &= f'(x) g(x) h(x) + f(x) g'(x) h(x) + f(x) g(x) h'(x). \end{aligned}$$

Example 12 Find the derivative of $y = x^3 \sin x (3^x)$

Solution
$$\begin{aligned} \frac{dy}{dx} &= (x^3)' \sin x (3^x) + x^3 (\sin x)' \times 3^x + x^3 \sin x (3^x)' \\ &= 3x^2 \sin x \times 3^x + x^3 \cos x \times 3^x + x^3 \sin x \times 3^x \ln 3. \end{aligned}$$

Derivative of a quotient of functions

ACTIVITY 3.6

1 Let $f(x) = e^x$ and $g(x) = x$. Evaluate

a $f'(x) g(x)$

b $g'(x) f(x)$

c $\frac{f'(x)}{g'(x)}$

d $\frac{f'(x) g(x) - g'(x) f(x)}{(g(x))^2}$



Let f be a differentiable function such that $f(x) \neq 0$. Then,

$$\begin{aligned} \left(\frac{1}{f(x)} \right)' &= \lim_{h \rightarrow 0} \frac{\frac{1}{f(x+h)} - \frac{1}{f(x)}}{h} = \lim_{h \rightarrow 0} \frac{f(x) - f(x+h)}{hf(x+h)f(x)} \\ &= \lim_{h \rightarrow 0} \frac{f(x) - f(x+h)}{h} \times \lim_{h \rightarrow 0} \frac{1}{f(x)f(x+h)} \\ &= -\lim_{h \rightarrow 0} \frac{f(x+h) - f(x)}{h} \times \frac{1}{f(x)f(x+0)} \\ &= -f'(x) \times \frac{1}{(f(x))^2} = \frac{-f'(x)}{(f(x))^2} \end{aligned}$$

2 Using $\left(\frac{1}{f(x)} \right)' = \frac{-f'(x)}{(f(x))^2}$, find the derivatives of each of the following functions.

a $f(x) = \frac{1}{x}$

b $f(x) = \frac{1}{\sqrt{x}}$

c $f(x) = \frac{1}{3x+1}$

d $f(x) = \frac{1}{\sqrt{x+1}}$

e $f(x) = \frac{1}{e^x+1}$

From the above **Activity**, you observed that

$$\begin{aligned} \left(\frac{f(x)}{g(x)} \right)' &= \left(f(x) \times \frac{1}{g(x)} \right)' = \frac{1}{g(x)} \times f'(x) + f(x) \times \left(\frac{1}{g(x)} \right)' \dots \text{By the product rule} \\ &= \frac{f'(x)}{g(x)} + f(x) \left(\frac{-g'(x)}{(g(x))^2} \right) = \frac{g(x)f'(x) - f(x)g'(x)}{(g(x))^2}. \end{aligned}$$

Theorem 3.9 The quotient rule

If f and g are differentiable functions and $g(x) \neq 0$, then $\frac{f}{g}$ is differentiable for all x at which f and g are differentiable with

$$\left(\frac{f}{g} \right)'(x) = \frac{g(x)f'(x) - f(x)g'(x)}{(g(x))^2}$$

Note:

If $y = \left(\frac{f}{g} \right)(x)$, then $\frac{dy}{dx} = \frac{g(x) \frac{d}{dx} f(x) - f(x) \frac{d}{dx} g(x)}{(g(x))^2}$

Example 13 Find the derivative of each of the following functions at the given number.

a $f(x) = \frac{x}{x+5}$ at $x = 1$

b $f(x) = \tan x$ at $x = \frac{\pi}{3}$

c $f(x) = \frac{\ln x}{x}$ at $x = e$

Solution Using the quotient rule we obtain,

a
$$f'(x) = \frac{(x+5)(x)' - x(x+5)'}{(x+5)^2} = \frac{x+5-x}{(x+5)^2} = \frac{5}{(x+5)^2}$$

$$\Rightarrow f'(1) = \frac{5}{(1+5)^2} = \frac{5}{36}$$

b
$$f'(x) = \left(\frac{\sin x}{\cos x} \right)' = \frac{\cos x(\sin x)' - \sin x(\cos x)'}{\cos^2 x}$$

$$= \frac{\cos^2 x + \sin^2 x}{\cos^2 x} = \frac{1}{\cos^2 x} = \sec^2 x \Rightarrow f' \left(\frac{\pi}{3} \right) = \sec^2 \left(\frac{\pi}{3} \right) = 4$$

Note:

✓ $\frac{d}{dx}(\tan x) = \sec^2 x.$

c
$$f'(x) = \left(\frac{\ln x}{x} \right)' = \frac{x(\ln x)' - \ln x(x)'}{x^2} = \frac{x \times \frac{1}{x} - \ln x \times 1}{x^2} = \frac{1 - \ln x}{x^2}$$

$$\Rightarrow f'(e) = \frac{1 - \ln e}{e^2} = 0$$

Example 14 Find the derivative of each of the following functions using the quotient rule.

a $f(x) = \frac{1}{\ln x}$ **b** $f(x) = \frac{1}{x^2 - 2}$ **c** $f(x) = \frac{4x^2 - 5x + 7}{x^2 - 3x + 1}$

d $f(x) = \frac{4^x}{x \ln x}$ **e** $f(x) = \frac{x \sin x}{x^2 + 1}$ **f** $f(x) = \frac{x \tan x}{e^x + \log_2 x}$

Solution

a $f(x) = \frac{1}{\ln x} \Rightarrow f'(x) = \frac{-(\ln x)'}{(\ln x)^2} = -\frac{1}{x \ln^2 x}$

b $f(x) = \frac{1}{x^2 - 2} \Rightarrow f'(x) = -\frac{(x^2 - 2)'}{(x^2 - 2)^2} = \frac{-2x}{(x^2 - 2)^2}$

$$\begin{aligned} \text{c} \quad f'(x) &= \frac{(4x^2 - 5x + 7)(x^2 - 3x + 1) - (x^2 - 3x + 1)(4x^2 - 5x + 7)}{(x^2 - 3x + 1)^2} \\ &= \frac{(8x - 5)(x^2 - 3x + 1) - (2x - 3)(4x^2 - 5x + 7)}{(x^2 - 3x + 1)^2} = \frac{-7x^2 - 6x + 16}{(x^2 - 3x + 1)^2} \end{aligned}$$

$$\begin{aligned} \text{d} \quad f'(x) &= \frac{(4^x)' x \ln x - 4^x (x \ln x)'}{(x \ln x)^2} = \frac{(4^x \ln 4) x \ln x - 4^x (\ln x + 1)}{(x \ln x)^2} \\ &= \frac{4^x (x \ln 4 \ln x - (\ln x + 1))}{(x \ln x)^2} \end{aligned}$$

$$\begin{aligned} \text{e} \quad f(x) = \frac{x \sin x}{x^2 + 1} \Rightarrow f'(x) &= \frac{(x \sin x)'(x^2 + 1) - (x^2 + 1)'(x \sin x)}{(x^2 + 1)^2} \\ &= \frac{(\sin x + x \cos x)(x^2 + 1) - 2x^2 \sin x}{(x^2 + 1)^2}. \end{aligned}$$

$$\begin{aligned} \text{f} \quad f'(x) &= \left(\frac{x \tan x}{e^x + \log_2 x} \right)' = \frac{(x \tan x)'(e^x + \log_2 x) - x \tan x (e^x + \log_2 x)'}{(e^x + \log_2 x)^2} \\ &= \frac{(\tan x + x \sec^2 x)(e^x + \log_2 x) - x \tan x \left(e^x + \frac{1}{x \ln 2} \right)}{(e^x + \log_2 x)^2} \end{aligned}$$

Example 15 In each of the following, find $\frac{dy}{dx}$.

$$\text{a} \quad y = \frac{x^2}{3x + 1} \quad \text{b} \quad y = \frac{x^2 + 1}{x^3 + x - 1} \quad \text{c} \quad y = \frac{x^2 + 4}{\cos x}$$

$$\text{d} \quad y = \frac{x + e^x}{2x + 1} \quad \text{e} \quad y = \frac{\cos x}{1 - \sin x}$$

Solution Applying the quotient rule,

$$\begin{aligned} \text{a} \quad y = \frac{x^2}{3x + 1} \Rightarrow \frac{dy}{dx} &= \frac{d}{dx} \left(\frac{x^2}{3x + 1} \right) = \frac{(3x + 1) \frac{d}{dx}(x^2) - x^2 \frac{d}{dx}(3x + 1)}{(3x + 1)^2} \\ \Rightarrow \frac{dy}{dx} &= \frac{d}{dx} \left(\frac{x^2}{3x + 1} \right) = \frac{(3x + 1) \frac{d}{dx}(x^2) - x^2 \frac{d}{dx}(3x + 1)}{(3x + 1)^2} \end{aligned}$$

$$= \frac{(3x+1)(2x) - x^2(3)}{(3x+1)^2} = \frac{6x^2 + 2x - 3x^2}{(3x+1)^2} = \frac{3x^2 + 2x}{(3x+1)^2}$$

$$\mathbf{b} \quad y = \frac{x^2 + 1}{x^3 + x - 1}$$

$$\begin{aligned} \Rightarrow \frac{dy}{dx} &= \frac{d}{dx} \left(\frac{x^2 + 1}{x^3 + x - 1} \right) = \frac{(x^3 + x - 1) \frac{d}{dx}(x^2 + 1) - (x^2 + 1) \frac{d}{dx}(x^3 + x - 1)}{(x^3 + x - 1)^2} \\ &= \frac{(x^3 + x - 1)(2x) - (x^2 + 1)(3x^2 + 1)}{(x^3 + x - 1)^2} = \frac{2x^4 + 2x^2 - 2x - (3x^4 + 4x^2 + 1)}{(x^3 + x - 1)^2} \\ &= -\frac{(x^4 + 2x^2 + 2x + 1)}{(x^3 + x - 1)^2} \end{aligned}$$

$$\mathbf{c} \quad \frac{d}{dx} \left(\frac{x^2 + 4}{\cos x} \right) = \frac{\cos x \frac{d}{dx}(x^2 + 4) - (x^2 + 4) \frac{d}{dx}(\cos x)}{\cos^2 x}$$

$$= \frac{2x \cos x + (x^2 + 4) \sin x}{\cos^2 x}$$

$$\mathbf{d} \quad \frac{dy}{dx} = \frac{d}{dx} \left(\frac{x + e^x}{2x + 1} \right) = \frac{(2x + 1) \frac{d}{dx}(x + e^x) - (x + e^x) \frac{d}{dx}(2x + 1)}{(2x + 1)^2}$$

$$= \frac{(2x + 1)(1 + e^x) - (x + e^x)(2)}{(2x + 1)^2} = \frac{2x + 1 + 2xe^x + e^x - 2x - 2e^x}{(2x + 1)^2}$$

$$= \frac{2xe^x - e^x + 1}{(2x + 1)^2}$$

$$\mathbf{e} \quad \frac{dy}{dx} = \frac{d}{dx} \left(\frac{\cos x}{1 - \sin x} \right) = \frac{(1 - \sin x) \frac{d}{dx} \cos x - \cos x \frac{d}{dx} (1 - \sin x)}{(1 - \sin x)^2}$$

$$= \frac{(1 - \sin x)(-\sin x) - \cos x(-\cos x)}{(1 - \sin x)^2} = \frac{-\sin x + \sin^2 x + \cos^2 x}{(1 - \sin x)^2}$$

$$= \frac{1 - \sin x}{(1 - \sin x)^2} = \frac{1}{1 - \sin x}$$

Exercise 3.8

1 Differentiate each of the following functions using the appropriate rules.

a $f(x) = 1 - x - x^2 + x^3$

b $g(x) = 7\sqrt{x} + e^x - \sin x$

c $h(x) = \frac{x}{x+5}$

d $l(x) = x + \sin x - e^x$

e $k(x) = \frac{x \sin x}{x - e^x}$

f $f(x) = \frac{\sqrt{x}}{x \cos x}$

g $g(x) = \csc x \sec x$

h $h(x) = \frac{1}{x} - \frac{1}{x^2} + \frac{\sec x}{x^2}$

i $k(x) = \frac{4x + 5}{x^2 + 1}$

j $f(x) = x^2 \ln x$

2 For each of the following functions, find $\frac{dy}{dx}$.

a $y = \ln x + e^x$

b $y = (x^2 - 2x - 3)e^x$

c $y = \frac{1 - \ln x}{x^2}$

d $y = \frac{x^2 + 1}{\cos x}$

e $y = \frac{e^x + x - 1}{x + 1}$

f $y = \frac{\sin x}{1 - \cos x}$

g $y = \frac{1 - \sin x}{x + \cos x}$

h $y = \frac{e^x \sin x}{e^x + 1}$

i $y = \frac{x^2}{x + \ln x}$

j $y = e^x(1 + x^2) \tan x$

k $y = \frac{\left(1 + \frac{1}{x^2}\right)}{1 - \frac{1}{x^2}}$

l $y = (e^x - \sqrt{x})^3$

3 In each of the following, find the equation of the tangent line to the graph of f at $(a, f(a))$.

a $f(x) = \frac{x-1}{x+1}; a=0$

b $f(x) = \frac{3x+1}{4-x^2}; a=1$

c $f(x) = e^x \sin x; a=0$

d $f(x) = \frac{x^2 - 4x}{e^{-x} + 1}; a=0$

3.3.3 The Chain Rule

Suppose you invest Birr 100 in a bank that pays r percent annual interest compounded monthly. Then at the end of 5 years the account balance (in Birr) will be

$$A(r) = 100 \left(1 + \frac{r}{1200} \right)^{60}$$

This is the composition of the two functions

$$f(r) = 1 + \frac{r}{1200} \text{ and } g(x) = 100x^{60}.$$

$$g(f(r)) = 100(f(r))^{60} \text{ i.e., } A(r) = g(f(r)).$$

In this section, you will see how to determine the derivative of a composition function like $A(r)$ using the derivatives of the component functions like f and g .

ACTIVITY 3.7



1 Look at the following table.

Function $y = f(x)$	Expanded form	$\frac{dy}{dx}$	The derivative in factorized form
$2x^3 + 1$	$2x^3 + 1$	$6x^2$	$1 \times \frac{dy}{dx}$
$(2x^3 + 1)^2$	$4x^6 + 4x^3 + 1$	$24x^5 + 12x^2$	$2(2x^3 + 1) \frac{d}{dx}(2x^3 + 1)$
$(2x^3 + 1)^3$	$8x^9 + 12x^6 + 6x^3 + 1$	$72x^8 + 72x^5 + 18x^2$ $= 18x^2(4x^6 + 4x^3 + 1)$ $= 18x^2(2x^3 + 1)^2$	$3(2x^3 + 1)^2 \frac{d}{dx}(2x^3 + 1)$
$(2x^3 + 1)^4$	$16x^{12} + 32x^9 + 24x^6 + 8x^3 + 1$	$192x^{11} + 288x^8 +$ $144x^5 + 24x^2$	$4(2x^3 + 1)^3 \frac{d}{dx}(2x^3 + 1)$

From the above table you might have noticed that the derivative is the product of the exponent, the expression with exponent reduced by 1 and the derivative of $2x^3 + 1$.

2 Find the derivatives of each of the following functions without expanding the power.

a $(2x^3 + 1)^4$ **b** $(2x^3 + 1)^{11}$ **c** $(2x^3 + 1)^n$

3 Let $f(x) = 3x + 1$, $g(x) = \cos x$ and $h(x) = \frac{3x - 1}{x^2 + 1}$. Evaluate each of the following functions.

a $f(g(x))$ **b** $f(h(x))$ **c** $h(g(x))$
d $f'(g(x))$ **e** $f'(g(x)).g'(x)$ **f** $h'(g(x)).g'(x)$

At this stage we can give the derivative of compositions of functions at a given point.

Theorem 3.10 The chain rule

Let g be differentiable at x_0 and f be differentiable at $g(x_0)$. Then $f \circ g$ is differentiable at x_0 and $(f \circ g)'(x_0) = f'(g(x_0)) \cdot g'(x_0)$

Proof:

For $g(x) - g(x_0) \neq 0$, we have,

$$\frac{f(g(x)) - f(g(x_0))}{x - x_0} = \frac{f(g(x)) - f(g(x_0))}{g(x) - g(x_0)} \times \frac{g(x) - g(x_0)}{x - x_0}$$

$$\begin{aligned} \text{Thus, } (f \circ g)'(x_0) &= \lim_{x \rightarrow x_0} \frac{(f \circ g)(x) - (f \circ g)(x_0)}{x - x_0} \\ &= \lim_{x \rightarrow x_0} \frac{f(g(x)) - f(g(x_0))}{g(x) - g(x_0)} \times \frac{g(x) - g(x_0)}{x - x_0} \\ &= \lim_{g(x) \rightarrow g(x_0)} \frac{f(g(x)) - f(g(x_0))}{g(x) - g(x_0)} \times \lim_{x \rightarrow x_0} \frac{g(x) - g(x_0)}{x - x_0} \\ &= f'(g(x_0)) \cdot g'(x_0) \end{aligned}$$

Example 16 Let $h(x) = \sin(3x + 1)$. Evaluate $h'\left(\frac{\pi - 2}{6}\right)$.

Solution h is the composition of the two simple functions $f(x) = \sin x$ and $g(x) = 3x + 1$. i.e., $h(x) = f(g(x))$.

By the chain rule, $h'(x) = f'(g(x_0)) \cdot g'(x_0)$.

But $f'(x) = \cos x$, $g'(x) = 3$ and $x_0 = \frac{\pi - 2}{6}$

$$\begin{aligned} \text{Thus } h'\left(\frac{\pi - 2}{6}\right) &= f'\left(g\left(\frac{\pi - 2}{6}\right)\right) \times g'\left(\frac{\pi - 2}{6}\right) = f'\left(3\left(\frac{\pi - 2}{6}\right) + 1\right) \times 3 \\ &= 3f'\left(\frac{\pi}{2}\right) = 3 \cos\left(\frac{\pi}{2}\right) = 0. \end{aligned}$$

Example 17 Find the derivative of $f(x) = \sqrt{1 + x^2}$ at $x = 2$.

Solution $f(x)$ is the composition of the functions $g(x) = \sqrt{x}$ and $h(x) = 1 + x^2$. i.e., $f(x) = g(h(x)) \Rightarrow f'(2) = g'(h(2)) \times h'(2) = g'(5) \times h'(2)$

But, $g'(x) = \frac{1}{2\sqrt{x}}$ and $h'(x) = 2x$

$$\text{Thus, } f'(2) = \frac{1}{2\sqrt{5}} \times 4 = \frac{2\sqrt{5}}{5}.$$

3.3.4 Derivatives of Composite Functions

If g is differentiable at x and f is differentiable at $g(x)$, then $f \circ g$ is differentiable at x with

$$(f \circ g)'(x) = f'(g(x)) \cdot g'(x)$$

Example 18 Find the derivative of $f(x) = e^{x^2+x+3}$.

Solution Let $g(x) = e^x$ and $h(x) = x^2 + x + 3$, then $f(x) = g(h(x))$, $g'(x) = e^x$ and $h'(x) = 2x + 1$. But, $f'(x) = g'(h(x)) \cdot h'(x)$

$$\Rightarrow f'(x) = g'(x^2 + x + 3) \times (2x + 1) = e^{x^2+x+3} (2x + 1) = f(x) \times (2x + 1).$$

$f'(x)$ can be found as follows.

$$f'(x) = \left(e^{x^2+x+3} \right)' = e^{x^2+x+3} \times (x^2 + x + 3)' = e^{x^2+x+3} \times (2x + 1)$$

Example 19 Look at each of the following derivatives.

a $\left((x + 5)^4 \right)' = 4(x + 5)^3 (x + 5)' = 4(x + 5)^3$

where $(x^4)' = 4x^3$ *derivative of the inner function*

b $\left((5x - 2)^{10} \right)' = 10(5x - 2)^9 (5x - 2)' = 10(5x - 2)^9 \times 5 = 50(5x - 2)^9$

$(x^{10})' = 10x^9$ *derivative of the inner function*

c $\left((3x^2 + 5x + 2)^8 \right)' = 8(3x^2 + 5x + 2)^7 (3x^2 + 5x + 2)' = 8(3x^2 + 5x + 2)^7 (6x + 5)$

d $(\cos(x^2 + x + 7))' = -\sin(x^2 + x + 7)(x^2 + x + 7)' = -\sin(x^2 + x + 7)(2x + 1)$
 $= -(2x + 1) \sin(x^2 + x + 7)$

e $\left(\sin \sqrt{x^2 + 4x + 1} \right)' = \cos \sqrt{x^2 + 4x + 1} \left(\sqrt{x^2 + 4x + 1} \right)'$
 $= \cos \sqrt{x^2 + 4x + 1} \times \frac{1}{2\sqrt{x^2 + 4x + 1}} (x^2 + 4x + 1)'$
 $= \cos \sqrt{x^2 + 4x + 1} \times \frac{2x + 4}{2\sqrt{x^2 + 4x + 1}}$
 $= \frac{x + 2}{\sqrt{x^2 + 4x + 1}} \cos \sqrt{x^2 + 4x + 1}$

This is the derivative of the composition of three functions. Therefore, you have;

Corollary 3.5

$$\left(f(g(h(x))) \right)' = f'(g(h(x))) \cdot g'(h(x)) \cdot h'(x).$$

Proof:-

$$\begin{aligned} \left(f(g(h(x))) \right)' &= f'(g(h(x))) \cdot (g(h(x)))' \text{ Why?} \\ &= f'(g(h(x))) \cdot g'(h(x)) \cdot h'(x) \end{aligned}$$

Example 20 Find the derivative of $k(x) = \cos^5(x^2 + 1)$.

Solution Notice that k is the composition of the three simple functions,

$$f(x) = x^5, g(x) = \cos x \text{ and } h(x) = x^2 + 1. \text{ i.e., } k(x) = f(g(h(x)))$$

$$\text{Also, } f'(x) = 5x^4, g'(x) = -\sin x, h'(x) = 2x \text{ and}$$

$$k'(x) = f'(g(h(x))) \cdot g'(h(x)) \cdot h'(x) = f'(g(x^2 + 1)) \cdot g'(x^2 + 1) \cdot (2x)$$

$$= f'(\cos(x^2 + 1)) \cdot (-\sin(x^2 + 1)) \cdot (2x) = 5 \cos^4(x^2 + 1) (-\sin(x^2 + 1)) (2x)$$

$$= -10x \sin(x^2 + 1) \cos^4(x^2 + 1)$$

In short,

$$(\cos^5(x^2 + 1))' = 5 \cos^4(x^2 + 1) \cdot (-\sin(x^2 + 1)) (2x) = -10x \sin(x^2 + 1) \cos^4(x^2 + 1)$$

The chain rule using the notation $\frac{dy}{dx}$

Let $y = f(u)$ and $u = g(x)$. Then,

$$y = f(g(x)), \frac{dy}{du} = f'(u) \text{ and } \frac{du}{dx} = g'(x)$$

$$\Rightarrow \frac{dy}{dx} = \frac{d}{dx} (f(g(x))) = f'(g(x)) \cdot g'(x) = f'(u) \cdot \frac{dy}{du} \cdot \frac{du}{dx}$$

Therefore, $\frac{dy}{dx} = \frac{dy}{du} \cdot \frac{du}{dx}$

Example 21 Find the derivative of each of the following functions with respect to x .

a $y = (3x + 4)^6$

b $y = \cos^6 x$

c $y = (x^3 + 1)^{\frac{3}{5}}$

d $y = \sqrt{3x^5 - 2x + 4}$

Solution

a $y = (3x + 4)^6$

Let $u = 3x + 4$, then $y = u^6 \Rightarrow \frac{du}{dx} = 3$ and $\frac{dy}{du} = 6u^5$

$$\Rightarrow \frac{dy}{dx} = \frac{dy}{du} \cdot \frac{du}{dx} = 6u^5 \times 3 = 18u^5 = 18(3x + 4)^5$$

In short, $\frac{dy}{dx} = \frac{d}{dx} (3x + 4)^6 = 6(3x + 4)^5 \cdot \frac{d}{dx} (3x + 4) = 18(3x + 4)^5$

b $y = \cos^6 x$

Let $u = \cos x$, then $y = u^6$, $\frac{dy}{du} = 6u^5$ and $\frac{du}{dx} = -\sin x$

$$\Rightarrow \frac{dy}{dx} = \frac{dy}{du} \cdot \frac{du}{dx} = 6u^5 (-\sin x) = -6 \sin x \cos^5 x$$

Observe that $\frac{d}{dx} \cos^6 x = 6 \cos^5 x \frac{d}{dx} \cos x = -6 \sin x \cos^5 x$

c $y = (x^3 + 1)^{\frac{3}{5}}$

Let $u = x^3 + 1$, then $y = u^{\frac{3}{5}}$ so that $\frac{du}{dx} = 3x^2$ and $\frac{dy}{du} = \frac{3}{5} u^{-\frac{2}{5}}$

$$\Rightarrow \frac{dy}{dx} = \frac{dy}{du} \cdot \frac{du}{dx} = \frac{3}{5} u^{-\frac{2}{5}} \cdot 3x^2 = \frac{3}{5} (x^3 + 1)^{-\frac{2}{5}} \cdot 3x^2 = \frac{9}{5} x^2 (x^3 + 1)^{-\frac{2}{5}} = \frac{9x^2}{5(x^3 + 1)^{\frac{2}{5}}}$$

d $y = \sqrt{3x^5 - 2x + 4}$

Let $u = 3x^5 - 2x + 4$, then $y = \sqrt{u}$

Hence, $\frac{du}{dx} = 15x^4 - 2$ and $\frac{dy}{du} = \frac{1}{2\sqrt{u}}$

$$\Rightarrow \frac{dy}{dx} = \frac{dy}{du} \cdot \frac{du}{dx} = \frac{1}{2\sqrt{u}} \cdot (15x^4 - 2) = \frac{1}{2\sqrt{3x^5 - 2x + 4}} \cdot (15x^4 - 2)$$

Example 22 Differentiate each of the following functions with respect to x .

a $y = \frac{x}{\sqrt{x^2 + 4}}$ **b** $y = \sqrt{\sin(x^2 + 1)}$ **c** $y = e^{\sqrt{x^2 + 5x + 4}}$

d $y = \frac{\log \sqrt{x^2 + 1}}{x + \sin x}$ **e** $y = \cos \sqrt{\log(\sqrt{x^2 + 1} + x)}$

Solution In this example, you differentiate each function without rewriting it as the composition of simple functions.

a $y = \frac{x}{\sqrt{x^2 + 4}}$. Here you apply the quotient rule and the chain rule

$$\begin{aligned} \frac{dy}{dx} &= \frac{(x)' \sqrt{x^2 + 4} - x (\sqrt{x^2 + 4})'}{(\sqrt{x^2 + 4})^2} \quad \text{Quotient rule} \\ &= \frac{\sqrt{x^2 + 4} - x \left(\frac{1}{2\sqrt{x^2 + 4}} \right) (x^2 + 4)'}{(x^2 + 4)} \quad \text{Chain rule} \end{aligned}$$

$$\begin{aligned}
 &= \frac{\sqrt{x^2 + 4} - \frac{x}{2\sqrt{x^2 + 4}}(2x)}{(x^2 + 4)} = \frac{(\sqrt{x^2 + 4})^2 - x^2}{(x^2 + 4)\sqrt{x^2 + 4}} \\
 &= \frac{x^2 + 4 - x^2}{(x^2 + 4)\sqrt{x^2 + 4}} = \frac{4}{(x^2 + 4)\sqrt{x^2 + 4}}
 \end{aligned}$$

b $y = \left(\sqrt{\sin(x^2 + 1)}\right)$

$$\begin{aligned}
 \Rightarrow \frac{dy}{dx} &= \frac{1}{2\sqrt{\sin(x^2 + 1)}} \cdot (\sin(x^2 + 1))' \text{ because } (\sqrt{x})' = \frac{1}{2\sqrt{x}} \\
 &= \frac{\cos(x^2 + 1)}{2\sqrt{\sin(x^2 + 1)}}(2x) = \frac{x \cos(x^2 + 1)}{\sqrt{\sin(x^2 + 1)}}
 \end{aligned}$$

c $y = e^{\sqrt{x^2 + 5x + 4}}$

$$\begin{aligned}
 \Rightarrow \frac{dy}{dx} &= e^{\sqrt{x^2 + 5x + 4}} \left(\sqrt{x^2 + 5x + 4}\right)' \text{ because } (e^x)' = e^x \\
 &= e^{\sqrt{x^2 + 5x + 4}} \times \frac{1}{2\sqrt{x^2 + 5x + 4}} (x^2 + 5x + 4)' \\
 &= \frac{e^{\sqrt{x^2 + 5x + 4}}}{2\sqrt{x^2 + 5x + 4}} (2x + 5)
 \end{aligned}$$

d $y = \frac{\log \sqrt{x^2 + 1}}{x + \sin x} = \frac{\frac{1}{2} \log(x^2 + 1)}{x + \sin x}$

$$\begin{aligned}
 \Rightarrow \frac{dy}{dx} &= \frac{1}{2} \frac{(x + \sin x)(\log(x^2 + 1))' - \log(x^2 + 1)(x + \sin x)'}{(x + \sin x)^2} \\
 &= \frac{1}{2} \frac{(x + \sin x) \left(\frac{1}{(x^2 + 1) \ln 10} (x^2 + 1)' \right) - \log(x^2 + 1) \cdot (1 + \cos x)}{(x + \sin x)^2} \\
 &= \frac{1}{2(x + \sin x)^2} \left(\frac{(x + \sin x)(2x)}{(x^2 + 1) \ln 10} - \log(x^2 + 1)(1 + \cos x) \right)
 \end{aligned}$$

e $y = \cos \sqrt{\log(\sqrt{x^2+1}+x)}$. This is the composition of several functions.

$$\begin{aligned} \Rightarrow \frac{dy}{dx} &= -\sin \sqrt{\log(\sqrt{x^2+1}+x)} \times \frac{1}{2\sqrt{\log(\sqrt{x^2+1}+x)}} \times \frac{1}{(\sqrt{x^2+1}+x)\ln 10} \times \left(\frac{x}{\sqrt{x^2+1}}+1\right) \\ &\quad - \frac{\sin \sqrt{\log \sqrt{x^2+1}+x}}{2\sqrt{\log \sqrt{x^2+1}+x}(\sqrt{x^2+1}+x)\ln 10} \left(\frac{x}{\sqrt{x^2+1}}+1\right) \end{aligned}$$

Example 23 Find the equation of the line tangent to the graph of $y = \ln\left(\frac{x^2}{x^2+2x}\right)$ at

$$x = 1.$$

Solution $y = \ln\left(\frac{x^2}{x^2+2x}\right) \Rightarrow y = \ln(x^2) - \ln(x^2+2x)$

$$\Rightarrow \frac{dy}{dx} = \frac{1}{x^2}(2x) - \frac{1}{(x^2+2x)} \cdot (2x+2) = \frac{2}{x} - \frac{2x+2}{x^2+2x}$$

$$\Rightarrow \text{The gradient is } \left. \frac{dy}{dx} \right|_{x=1} = \frac{2}{1} - \frac{2(1)+2}{1^2+2(1)} = \frac{2}{3}$$

\Rightarrow The equation of the tangent line is

$$y - \ln\left(\frac{1}{1+2}\right) = \frac{2}{3}(x-1) \Rightarrow y = \frac{2}{3}x - \frac{2}{3} - \ln 3.$$

Exercise 3.9

1 Use the chain rule and any other appropriate rule to differentiate each of the following functions.

a $f(x) = e^{x+6}$

b $f(x) = (x+5)^{10}$

c $f(x) = (4x+5)^{12}$

d $f(x) = \sin(3x)$

e $f(x) = \cos(x^2+1)$

f $f(x) = \frac{e^{(x+2)}}{xe^x-1}$

g $f(x) = e^{-5x} \sin(4x^2+5x+1)$

h $f(x) = \sqrt{x^2+2x+3}$

i $f(x) = \log_3(x^2+4)$

j $f(x) = \frac{x^2}{x+\ln(x^2+9)}$

k $f(x) = \frac{\sin x}{\sqrt{2x+1}}$

l $f(x) = \sin(x^2) + \cos(x^2)$

m $f(x) = \ln\left(\frac{1}{x^2+1}\right)$

n $f(x) = \ln \sqrt{x^2+1}$

o $f(x) = \sin \sqrt{\ln(x^2+7)}$

p $\log_a x$

q $f(x) = e^{-\sqrt{x^2+1}} \sin(\sqrt{x^2+1})$ **r** $f(x) = \ln \sqrt{\cos(x^2+3)}$

2 Find the equation of the line tangent to the graph of f at $(a, f(a))$, if

a $f(x) = xe^{-\sqrt{x+1}}$ at $(0, 0)$ **b** $f(x) = e^{2-x^2}$ at $(1, e)$

c $f(x) = \ln\left(\frac{x+1}{\cos x}\right)$ at $(0, 0)$ **d** $f(x) = \frac{e^{3x+2}}{1-2x}$ at $\left(-1, \frac{1}{3e}\right)$

e $f(x) = (8-x^3)\sqrt{2-x}$ at $(-2, 32)$

3 Find $\frac{dy}{dx}$.

a $y = \sqrt{1+x^6}$ **b** $y = \sqrt{1+3x^2} e^x$ **c** $y = \frac{2x^3}{\sqrt{1+x^4}}$

d $y = \sqrt{\frac{x^2}{x^3+1}}$ **e** $y = \left(\frac{2x-1}{3-4x}\right)^9$ **f** $y = \cos(\ln \sqrt{e^x})$

g $y = (ax + b)^r$; where r is a real number.

3.3.5 Higher Order Derivatives of a Function

You have seen that for a function f , f' is the first derivative or simply the derivative of f .

f' is a function which assigns $x \rightarrow \lim_{t \rightarrow x} \frac{f(t) - f(x)}{t - x}$.

For instance if $f(x) = x^2 + 1$, then $f'(x) = 2x$ which is a function, too. Therefore, you can compute the derivative of f' which is $(f')'(x) = (2x)' = 2$.

ACTIVITY 3.8



- 1** Let $f(x) = x^3 + 4x + 5$.
- a** Find $f'(x)$ **b** Differentiate $f'(x)$ with respect to x .
- 2** If $f(x) = \begin{cases} x^2, & \text{if } x < 3, \\ 6x - 9, & \text{if } x \geq 3. \end{cases}$
- a** Find $f'(x)$ **b** Sketch the graph of $f'(x)$.
- c** Find the derivative of $f'(x)$ at $x = 3$.
- 3** Let $f(x) = x^3 + 1$. Sketch the graphs of $f'(x)$ and the derivative of $f'(x)$ using the same coordinate system.
- 4** Let $f(x) = |x|x$.
- a** Find $f'(x)$ **b** Find $(f'(x))'(0)$

The second derivative of a function f , denoted by $f''(x)$ is the derivative of the first derivative.

$$\text{i.e., } f''(x) = (f'(x))'$$

You say that f is twice differentiable or the second derivative of f exists or $f'(x)$ is

differentiable provided that $f''(x) = \lim_{t \rightarrow x} \frac{f'(t) - f'(x)}{t - x}$ exists.

Example 24 Find the second derivatives for each of the following functions.

- a** $f(x) = x^2$ **b** $f(x) = x^3$ **c** $f(x) = \sin x$
d $f(x) = e^x$ **e** $f(x) = xe^x$ **f** $f(x) = x \sin x$
g $f(x) = e^x \sin x$

Solution

- a** $f(x) = x^2 \Rightarrow f'(x) = 2x \Rightarrow f''(x) = 2.$
b $f(x) = x^3 \Rightarrow f'(x) = 3x^2 \Rightarrow f''(x) = 6x$
c $f(x) = \sin x \Rightarrow f'(x) = \cos x \Rightarrow f''(x) = -\sin x$
d $f(x) = e^x \Rightarrow f'(x) = e^x \Rightarrow f''(x) = e^x$
e $f(x) = xe^x \Rightarrow f'(x) = (x)'e^x + x(e^x)'$ by the product rule
 $= e^x + xe^x = e^x(1 + x) \Rightarrow f''(x) = (e^x)'(1 + x) + e^x(1 + x)'$
 $= e^x(1 + x) + e^x = e^x(2 + x)$
f $f(x) = x \sin x \Rightarrow f'(x) = \sin x + x \cos x$
 $\Rightarrow f''(x) = \cos x + \cos x - x \sin x = 2 \cos x - x \sin x$
g $f(x) = e^x \sin x \Rightarrow f'(x) = e^x \sin x + e^x \cos x = e^x(\sin x + \cos x)$
 $\Rightarrow f''(x) = (e^x)'(\sin x + \cos x) + e^x(\sin x + \cos x)'$
 $= e^x(\sin x + \cos x) + e^x(\cos x - \sin x)$
 $= e^x(\sin x + \cos x + \cos x - \sin x) = 2e^x \cos x.$

 **Note:**

If $y = f(x)$, then $\frac{dy}{dx} = f'(x)$ so that $f''(x) = \frac{d}{dx} f'(x) = \frac{d}{dx} \left(\frac{dy}{dx} \right)$

$\frac{d}{dx} \left(\frac{dy}{dx} \right)$ is denoted by $\frac{d^2 y}{dx^2}$. i.e., $\frac{d^2 y}{dx^2} = f''(x)$ Also, $\frac{d^2}{dx^2} f(x) = f''(x).$

Example 25 For each of the following, find $\frac{d^2y}{dx^2}$.

a $y = x^4$

b $y = \sqrt{x}$

c $y = \frac{x}{x+1}$

d $y = \frac{3}{\sqrt{x-1}}$

e $y = \sqrt{e^{4x+3}}$

f $y = e^{-x^2+2x+1}$

g $y = \ln x$

h $y = \frac{x+1}{x^2+1}$

i $y = \frac{\sin x}{\sqrt{x}}$

j $y = \frac{x}{\sqrt{x^2+1}}$

k $y = \frac{x^2}{x+\ln x}$

l $y = \ln\left(\frac{x}{\cos x}\right); 0 < x < \frac{\pi}{2}$

Solution

a $y = x^4 \Rightarrow \frac{d}{dx}(x^4) = 4x^3 \Rightarrow \frac{d^2y}{dx^2} = \frac{d}{dx}(4x^3) = 12x^2.$

b $y = \sqrt{x} \Rightarrow \frac{dy}{dx} = \frac{1}{2\sqrt{x}} = \frac{1}{2}x^{-\frac{1}{2}}$
 $\Rightarrow \frac{d^2y}{dx^2} = \frac{d}{dx}\left(\frac{1}{2}x^{-\frac{1}{2}}\right) = -\frac{1}{4}x^{-\frac{3}{2}} = -\frac{1}{4x\sqrt{x}}.$

c $y = \frac{x}{x+1} \Rightarrow \frac{dy}{dx} = \frac{(x)'(x+1) - x(x+1)'}{(x+1)^2}$. *Quotient Rule*
 $= \frac{x+1-x}{(x+1)^2} = \frac{1}{(x+1)^2} = (x+1)^{-2}$
 $\Rightarrow \frac{d^2y}{dx^2} = \frac{d}{dx}((x+1)^{-2}) = -2(x+1)^{-3} = -\frac{2}{(x+1)^3}$

d $y = \frac{3}{\sqrt{x-1}} = 3(x-1)^{-\frac{1}{2}} \Rightarrow \frac{dy}{dx} = 3\left(-\frac{1}{2}\right)(x-1)^{-\frac{3}{2}} = -\frac{3}{2}(x-1)^{-\frac{3}{2}}$
 $\Rightarrow \frac{d^2y}{dx^2} = \frac{d}{dx}\left(-\frac{3}{2}(x-1)^{-\frac{3}{2}}\right) = -\frac{3}{2}\left(-\frac{3}{2}(x-1)^{-\frac{5}{2}}\right)$
 $= \frac{9}{4}(x-1)^{-\frac{5}{2}} = \frac{9}{4(x-1)^2\sqrt{x-1}}.$

e $y = \sqrt{e^{4x+3}} \Rightarrow \frac{dy}{dx} = \frac{1}{2\sqrt{e^{4x+3}}} \times e^{4x+3} \times 4 = \frac{2e^{4x+3}}{\sqrt{e^{4x+3}}} = 2e^{4x+3} \frac{\sqrt{e^{4x+3}}}{e^{4x+3}} = 2\sqrt{e^{4x+3}}$

Also, $y = \sqrt{e^{4x+3}} = e^{\frac{4x+3}{2}}$
 $\Rightarrow \frac{dy}{dx} = e^{\frac{4x+3}{2}} \times \frac{d}{dx}\left(\frac{4x+3}{2}\right) = e^{\frac{4x+3}{2}} \times 2 = 2\sqrt{e^{4x+3}}$

$$\begin{aligned}\Rightarrow \frac{d^2 y}{dx^2} &= \frac{d}{dx} \left(2e^{\frac{4x+3}{2}} \right) = 2e^{\frac{4x+3}{2}} \times \frac{d}{dx} \left(\frac{4x+3}{2} \right) \\ &= 2e^{\frac{4x+3}{2}} \times 2 = 4e^{\frac{4x+3}{2}} = 4\sqrt{e^{4x+3}}\end{aligned}$$

$$\begin{aligned}\mathbf{f} \quad y = e^{-x^2+2x+1} &\Rightarrow \frac{dy}{dx} = e^{-x^2+2x+1} \frac{d}{dx}(-x^2+2x+1) \\ &= e^{-x^2+2x+1}(-2x+2)\end{aligned}$$

$$\begin{aligned}\frac{d^2 y}{dx^2} &= \left(e^{-x^2+2x+1}(-2x+2) \right)' = \left(e^{-x^2+2x+1} \right)'(-2x+2) + e^{-x^2+2x+1}(-2x+2)' \\ &= e^{-x^2+2x+1}(-2x+2)^2 + e^{-x^2+2x+1}(-2) = e^{-x^2+2x+1}(4x^2-8x+2) \\ &= e^{-x^2+2x+1}((2-2x)^2-2)\end{aligned}$$

$$\mathbf{g} \quad y = \ln x \Rightarrow \frac{dy}{dx} = \frac{1}{x} \Rightarrow \frac{d^2 y}{dx^2} = -\frac{1}{x^2}$$

$$\begin{aligned}\mathbf{h} \quad y = \frac{x+1}{x^2+1} &\Rightarrow \frac{dy}{dx} = \frac{(x^2+1)\frac{d}{dx}(x+1) - (x+1)\frac{d}{dx}(x^2+1)}{(x^2+1)^2} = \frac{x^2+1-(x+1)(2x)}{(x^2+1)^2} \\ &= \frac{x^2+1-2x^2-2x}{(x^2+1)^2} = \frac{1-x^2-2x}{(x^2+1)^2} \Rightarrow \frac{d^2 y}{dx^2} = \frac{2x^3+6x^2-6x-2}{(x^2+1)^3}\end{aligned}$$

$$\begin{aligned}\mathbf{i} \quad y = \frac{\sin x}{\sqrt{x}} &\Rightarrow \frac{dy}{dx} = \frac{\sqrt{x}(\sin x)' - \sin(\sqrt{x})'}{(\sqrt{x})^2} = \frac{\sqrt{x} \cos x - \sin x \left(\frac{1}{2\sqrt{x}} \right)}{x} \\ &= \frac{2x \cos x - \sin x}{2x\sqrt{x}}\end{aligned}$$

$$\begin{aligned}\frac{d^2 y}{dx^2} &= \left(\frac{2x \cos x - \sin x}{2x\sqrt{x}} \right)' = \frac{1}{2} \left(\frac{2x \cos x - \sin x}{x^{\frac{3}{2}}} \right)' \\ &= \frac{(2x \cos x - \sin x)' x^{\frac{3}{2}} - \left(x^{\frac{3}{2}} \right)' (2x \cos x - \sin x)}{2 \left(x^{\frac{3}{2}} \right)^2} \\ &= \frac{(2 \cos x - 2x \sin x - \cos x) x^{\frac{3}{2}} - \frac{3}{2} x^{\frac{1}{2}} (2x \cos x - \sin x)}{2x^3}\end{aligned}$$

$$= \frac{(\cos x - 2x \sin x)x^{\frac{3}{2}} - \frac{3}{2}x^{\frac{1}{2}}(2x \cos x - \sin x)}{2x^3}$$

$$\text{j } y = \frac{x}{\sqrt{x^2+1}} \Rightarrow \frac{dy}{dx} = \frac{(x)' \sqrt{x^2+1} - x(\sqrt{x^2+1})'}{(\sqrt{x^2+1})^2} = \frac{\sqrt{x^2+1} - x \frac{1}{2\sqrt{x^2+1}} \times 2x}{x^2+1}$$

$$= \frac{(x^2+1) - x^2}{(x^2+1)\sqrt{x^2+1}} = \frac{1}{(x^2+1)\sqrt{x^2+1}} = (x^2+1)^{-\frac{5}{2}}$$

$$\begin{aligned} \frac{d^2y}{dx^2} &= \left((x^2+1)^{-\frac{5}{2}} \right)' = -\frac{5}{2}(x^2+1)^{-\frac{5}{2}} \times 2x \\ &= \frac{-5x}{(x^2+1)^{\frac{5}{2}}} = \frac{-5x}{(x^2+1)^2 \sqrt{x^2+1}} \end{aligned}$$

$$\text{k } y = \frac{x^2}{x+\ln x} \Rightarrow \frac{dy}{dx} = \frac{(x^2)'(x+\ln x) - x^2(x+\ln x)'}{(x+\ln x)^2} = \frac{2x(x+\ln x) - x^2 \left(1 + \frac{1}{x}\right)}{(x+\ln x)^2}$$

$$= \frac{2x^2 + 2x \ln x - x^2 - x}{(x+\ln x)^2} = \frac{x^2 + 2x \ln x - x}{(x+\ln x)^2}$$

$$\begin{aligned} \frac{d^2y}{dx^2} &= \left(\frac{x^2 + 2x \ln x - x}{(x+\ln x)^2} \right)' \\ &= \frac{(x^2 + 2x \ln x - x)'(x+\ln x)^2 - ((x+\ln x)^2)'(x^2 + 2x \ln x - x)}{(x+\ln x)^4} \\ &= \frac{\left(2x + 2 \ln x + 2x \left(\frac{1}{x}\right) - 1\right)(x+\ln x)^2 - 2(x+\ln x) \left(1 + \frac{1}{x}\right)(x^2 + 2x \ln x - x)}{(x+\ln x)^4} \\ &= \frac{(2x + 2 \ln x + 1)(x+\ln x) - 2 \left(1 + \frac{1}{x}\right)(x^2 + 2x \ln x - x)}{(x+\ln x)^3} \end{aligned}$$

$$\text{l } y = \ln \left(\frac{x}{\cos x} \right) = \ln(x) - \ln(\cos x) \text{ because } 0 < x < \frac{\pi}{2}$$

$$\Rightarrow \frac{dy}{dx} = \frac{d}{dx}(\ln x - \ln(\cos x)) = \frac{1}{x} - \frac{1}{\cos x} \times (-\sin x) = \frac{1}{x} + \tan x$$

$$\frac{d^2y}{dx^2} = -\frac{1}{x^2} + \sec^2 x.$$

Similarly, we define the third, fourth, etc. derivatives of a function f as follows:
 The third derivative of a function f is the derivative of the second derivative. i.e.,

$$f'''(x) = ((f''(x)))'$$

Also, the fourth derivative of a function f is the derivative of the third derivative.

In general, for $n \geq 3$, the n^{th} derivative of f , denoted by $f^{(n)}(x)$ is defined as

$$f^{(n)}(x) = \lim_{t \rightarrow x} \frac{f^{(n-1)}(t) - f^{(n-1)}(x)}{t - x}$$

If this limit exists, then we say that f is n -times differentiable or the n^{th} derivative of $f(x)$ exists.

Example 26 Find the fourth derivative of

a $f(x) = x^4 - 5x^3 + 6x^2 + 7x + 1$ **b** $f(x) = \sin x$

Solution

a $f(x) = x^4 - 5x^3 + 6x^2 + 7x + 1$
 $\Rightarrow f'(x) = (x^4 - 5x^3 + 6x^2 + 7x + 1)' = 4x^3 - 15x^2 + 12x + 7$
 $\Rightarrow f''(x) = (4x^3 - 15x^2 + 12x + 7)' = 12x^2 - 30x + 12$
 $\Rightarrow f^{(3)}(x) = (12x^2 - 30x + 12)' = 24x - 30$
 $\Rightarrow f^{(4)}(x) = 24$

Note that, for $n \geq 5$, $f^{(n)}(x) = 0$

b $f(x) = \sin x$,
 $\Rightarrow f'(x) = \cos x \Rightarrow f''(x) = -\sin x$
 $\Rightarrow f'''(x) = -\cos x \Rightarrow f^{(4)}(x) = \sin x$.

NOTATION

If $y = f(x)$, then, we write $f^{(n)}(x) = \frac{d^n y}{dx^n} = \frac{d^n}{dx^n} f(x) = D^n f(x)$

Example 27 Let $y = xe^x$. Find $\frac{d^n y}{dx^n}$.

Solution $y = xe^x \Rightarrow \frac{dy}{dx} = (x)' e^x + x(e^x)' = e^x + xe^x = e^x(1+x)$

$$\frac{d^2 y}{dx^2} = (e^x(1+x))' = (e^x)'(1+x) + e^x(1+x)' = e^x(1+x) + e^x = e^x(2+x)$$

$$\frac{d^3 y}{dx^3} = (e^x(2+x))' = (e^x)'(2+x) + e^x(2+x)' = e^x(2+x) + e^x = e^x(3+x)$$

From this pattern we conclude that, $\frac{d^n y}{dx^n} = e^x(n+x)$

Example 28 Let f be a n -times differentiable function. If $g(x) = f(3x + 1)$, find $g^n(x)$.

Solution $g(x) = f(3x + 1)$

$$\Rightarrow g'(x) = f'(3x + 1) \cdot (3x + 1)' \quad \text{by chain rule.}$$

$$= 3f'(3x + 1)$$

$$\Rightarrow g''(x) = 3f''(3x + 1)(3x + 1)' = 3f''(3x + 1) \times 3 = 3^2 f''(3x + 1)$$

$$g^{(3)}(x) = 3^2 f^{(3)}(3x + 1)(3x + 1)' = 3^2 f^{(3)}(3x + 1) \times 3$$

$$= 3^3 f^{(3)}(3x + 1)$$

From this pattern one can see that $g^{(n)}(x) = 3^n f^{(n)}(3x + 1)$.

Example 29 Let $f(x) = |x|x^2$. Find the third derivative of f .

Solution $f(x) = |x|x^2 = \begin{cases} x^3, & \text{if } x \geq 0 \\ -x^3, & \text{if } x < 0 \end{cases} \Rightarrow f'(x) = \begin{cases} 3x^2, & \text{if } x \geq 0 \\ -3x^2, & \text{if } x < 0 \end{cases}$

$$\Rightarrow f''(x) = \begin{cases} 6x, & \text{if } x \geq 0 \\ -6x, & \text{if } x < 0 \end{cases} \Rightarrow f^{(3)}(x) = \begin{cases} 6, & \text{if } x > 0 \\ \cancel{0}, & \text{if } x = 0 \\ -6, & \text{if } x < 0 \end{cases}$$

$$f^{(3)}(0) = \lim_{x \rightarrow 0} \frac{f''(x) - f''(0)}{x - 0} = \lim_{x \rightarrow 0} \frac{f''(x)}{x}$$

$$\text{But, } \lim_{x \rightarrow 0^+} \frac{f''(x)}{x} = \lim_{x \rightarrow 0^+} \frac{6x}{x} = 6 \quad \text{and} \quad \lim_{x \rightarrow 0^-} \frac{f''(x)}{x} = \lim_{x \rightarrow 0^-} \frac{-6x}{x} = -6$$

$$\Rightarrow f^{(3)}(0) = \text{doesn't exist.}$$

This is an example of a function which is twice differentiable at 0 but it is not three times differentiable at 0.

Example 30 Let $f(x) = a_n x^n + a_{n-1} x^{n-1} + \dots + a_2 x^2 + a_1 x + a_0$

be a polynomial function of degree n . Show that $f^{(k)}(x) = 0$ for all $k > n$.

Solution $f'(x) = n a_n x^{n-1} + (n-1) a_{n-1} x^{n-2} + \dots + 2 a_2 x$

$$f''(x) = n(n-1) a_n x^{n-2} + (n-1)(n-2) a_{n-1} x^{n-3} + \dots + 2 a_2$$

$$f^{(3)}(x) = n(n-1)(n-2) a_n x^{n-3} + (n-1)(n-2)(n-3) a_{n-1} x^{n-4} + \dots + 6 a_3$$

⋮

$$f^{(n-1)}(x) = n(n-1)(n-2)\dots(n-1) a_n x$$

$$f^{(n)}(x) = n! a_n$$

$$\Rightarrow f^{(n+1)}(x) = 0.$$

Exercise 3.10

1 Find the second derivative of each of the following functions.

a $f(x) = 3x - 9$

b $f(x) = 4x^3 - 6x^2 + 7x + 1$

c $f(x) = \sqrt{x} + \sin x$

d $f(x) = x\sqrt{x} + \sin x$

e $f(x) = \frac{\sin x}{x+1}$

f $f(x) = \ln(x^2 + 1)$

g $f(x) = \frac{x^2 - 4}{x+1}$

h $f(x) = \sec x$

i $f(x) = \frac{x^2}{\sqrt{4-x^2}}$

2 For each of the following, find $\frac{d^2y}{dx^2}$.

a $y = e^{3x+2}$

b $y = \log_3(\sqrt{x+1})$

c $y = \ln\left(\frac{1}{x^2+1}\right)$

d $y = \cos^2(2x+1)$

e $y = (\ln x)^3$

f $y = \ln(1-x^3)$

g $y = \ln\left(\frac{x}{\sqrt{x+2}}\right)$

h $y = e^{-\sqrt{x}} \sin \sqrt{x}$

i $y = \sin(2x \cos x)$

j $y = \ln(\ln x)$

k $y = (x+1)\sqrt{x^2+1}$

3 Find a formula for the n^{th} derivative of each of the following functions for the given values of n .

a $f(x) = e^{(3x+1)}; n \in \mathbb{N}$

b $f(x) = e^{x^2}; n = 6$

c $f(x) = \ln\left(\frac{1}{x^2+1}\right); n = 4$

d $f(x) = e^{-x^2+7x-3}; n = 4$



Key Terms

chain rule

gradient

rate of change

slope

derivative

product rule

rules

tangent

differentiation

quotient rule

secant

work



Summary

1 *The slope (gradient) of the graph of $y = f(x)$ at point P .*

- i** A line which touches a (continuous) graph at exactly one point is said to be a tangent line at that point, called the point of tangency.
- ii** The slope of the graph of $y = f(x)$ at a point is the slope of the tangent line at the point of tangency.
- iii** The slope of $y = f(x)$ at $(a, f(a))$ is $m_a = \lim_{x \rightarrow a} \frac{f(x) - f(a)}{x - a}$.
- iv** The equation of the tangent line at $(a, f(a))$ is $y - f(a) = m_a(x - a)$.

2 *Differentiation of a function at a point*

i *The Derivative*

Let x_0 be in the domain of a function f . Then, $f'(x) = \lim_{t \rightarrow x} \frac{f(t) - f(x)}{t - x}$

Also, $f'(x) = \lim_{h \rightarrow 0} \frac{f(x+h) - f(x)}{h}$

ii *Other notation*

Some of the other notations for derivatives are

$$\frac{dy}{dx}, \frac{d}{dx} f(x), D(f(x))$$

If $y = f(x)$, then the derivative at point a , $f'(a)$ is also denoted by

$$\left. \frac{dy}{dx} \right|_{x=a}$$

3 *Differentiability on an interval*

A function f is differentiable on an open interval (a, b) , if f is differentiable at each point on (a, b) . f is differentiable on the closed interval $[a, b]$, if it is differentiable on (a, b) and the one side limit

$$\lim_{x \rightarrow a^+} f'(x) \text{ and } \lim_{x \rightarrow b^-} f'(x) \text{ both exist.}$$

4 *The Derivatives of some functions*

i *The Derivative of a constant function is 0.*

$$\frac{d}{dx}(c) = 0$$

ii *The Derivative of the power function*

If $f(x) = x^r$, then $f'(x) = rx^{r-1}$

iii The Derivative of simple trigonometric functions

- ✓ If $f(x) = \sin x$, then $f'(x) = \cos x$
- ✓ If $f(x) = \cos x$, then $f'(x) = -\sin x$

iv The Derivatives of exponential functions

- ✓ If $f(x) = e^x$, then $f'(x) = e^x$
- ✓ If $f(x) = a^x$; $a > 0$, then $f'(x) = a^x \ln a$

v The Derivatives of logarithmic functions

- ✓ If $f(x) = \ln x$, then $f'(x) = \frac{1}{x}$
- ✓ If $f(x) = \log_a x$; $a > 0$ and $a \neq 1$, then $f'(x) = \frac{1}{x \ln a}$.

5 Derivatives of combinations of functions

Let f and g be differentiable functions.

i The derivatives of a sum or a difference.

- ✓ **The sum rule**
 $(f + g)'(x) = f'(x) + g'(x)$

- ✓ **The difference rule**
 $(f - g)'(x) = f'(x) - g'(x)$

ii The Derivatives of products and quotients.

- ✓ **The product rule**
 $(fg)'(x) = f'(x)g(x) + g'(x)f(x)$

- ✓ **The quotient rule**
$$\left(\frac{f}{g}\right)'(x) = \frac{f'(x)g(x) - g'(x)f(x)}{(g(x))^2}$$

6 Differentiation of compositions of functions**The Chain Rule**

Let f and g be differentiable functions. Then,

$$(f \circ g)'(x) = f'(g(x)) \cdot g'(x).$$

If u is a function of x , $y = f(u)$, $u = g(x)$, then

$$\frac{dy}{dx} = (f \circ g)'(x) = \frac{dy}{du} \cdot \frac{du}{dx}$$

- i** $\frac{d}{dx} u^n = nu^{n-1} \frac{du}{dx}$
- ii** $\frac{d}{dx} \sin u = \cos u \frac{du}{dx}$

$$\text{iii} \quad \frac{d}{dx} \cos u = -\sin u \frac{du}{dx}$$

$$\text{iv} \quad \frac{d}{dx} e^u = e^u \frac{du}{dx}$$

$$\text{v} \quad \frac{d}{dx} a^u = a^u \ln a \frac{du}{dx}$$

$$\text{vi} \quad \frac{d}{dx} \ln u = \frac{1}{u} \frac{du}{dx}$$

$$\text{vii} \quad \frac{d}{dx} \log_a u = \frac{1}{u \ln a} \frac{du}{dx}$$

7 Higher Derivatives

i The second Derivative

$$f''(x) = \lim_{t \rightarrow x} \frac{f'(t) - f'(x)}{t - x}$$

ii The n^{th} Derivatives; $n \geq 3$

$$f^{(n)}(x) = \lim_{t \rightarrow x} \frac{f^{(n-1)}(t) - f^{(n-1)}(x)}{t - x}$$

$$\text{If } y = f(x), \text{ then, } \frac{d^2 y}{dx^2} = f''(x); \quad \frac{d}{dx} \left(\frac{dy}{dx} \right) = \frac{d^2 y}{dx^2}$$

$$\frac{d^n y}{dx^n} = f^{(n)}(x).$$



Review Exercises on Unit 3

In Exercises 1 – 8, find the difference Quotient of f at a .

$$1 \quad f(x) = 4x + 3; a = -2 \quad 2 \quad f(x) = 2x^2 + 1; a = -1 \quad 3 \quad f(x) = \frac{x+1}{x-2}; a = -2$$

$$4 \quad f(x) = \frac{x+1}{x^2}; a = -\frac{1}{2} \quad 5 \quad f(x) = |x+4|; a = -4 \quad 6 \quad f(x) = \sqrt{x} + 5; a = \frac{9}{4}$$

$$7 \quad f(x) = 2^x; a = 0 \quad 8 \quad f(x) = \sqrt{1-3x^2}; a = \frac{\sqrt{3}}{4}$$

In Exercises 9 – 53, find the derivative of the expression with respect to x .

$$9 \quad 9$$

$$10 \quad \pi^2 + \frac{1}{\sqrt{2}}$$

$$11 \quad x^2 - 3x + 1$$

$$12 \quad 4x^2 - 8x$$

$$13 \quad x^4 - 7x^3 + 2$$

$$14 \quad (x-5)(3x+4)$$

$$15 \quad (x-3)^2$$

$$16 \quad (5x+1)(5x-1)(x-5)$$

$$17 \quad 4x^3 - x^{\frac{1}{3}} + \sqrt{x} + 1$$

$$18 \quad 3^{(x-2)} + \sqrt{x} + 5x^2 - \frac{1}{x}$$

$$19 \quad e^{-x} + e^x$$

$$20 \quad \sin(4x)$$

$$21 \quad \cos(x^2 + 4)$$

$$22 \quad \tan(6x - 1)$$

$$23 \quad \ln(7x + 3)$$

$$24 \quad \frac{x^2 + 4}{x}$$

$$25 \quad x - 2(x+1)^2$$

$$26 \quad \frac{x^3 - 5x + 3}{x^4}$$

- 27** $5x(x+1)$ **28** $1+x^{-1}+x^{-2}+x^{-3}$ **29** $\frac{x-1}{x\sqrt{x}}$
30 $\sqrt{1-3x^2}$ **31** $\frac{x^2+1}{\log_2 x}$ **32** e^{4-x^2}
33 $\frac{1}{x^{\frac{1}{3}}} + \sqrt[3]{x^2} + \sqrt[4]{x^3}$ **34** xe^{1-x} **35** $x^{-2}(e^x+1)$
36 $(\ln x)(x^2+1)$ **37** $(2x+1)^4$ **38** $\frac{(x-1)^3}{\sqrt{x}}$
39 $x \ln x - x$ **40** $\log \sqrt{x^2+2}$ **41** $\sqrt{\ln x} + \sqrt{e^x} + 2^x$
42 $\sqrt{\log \sqrt{x}}$ **43** $e^x \cos x$ **44** $\left(\frac{1}{x \sin x}\right)^{\frac{5}{3}}$
45 $\cos \sqrt{\ln(x^2+1)}$ **46** $\tan\left(\frac{x^2-1}{x}\right)$ **47** $\sec^2(x+3)$
48 $x^{-2}(\sin(x^2))$ **49** $\frac{x^3-4x+5}{x^2+1}$ **50** $\frac{e^x \sin x}{\ln x}$
51 $x \sqrt{1-(2+x)^{\frac{3}{2}}}$ **52** $e^{\sin \sqrt{x+3}}$ **53** $e^x \sin x$
54 For each of the following, find $f'(x)$.

a $f(x) = \begin{cases} x^3, & \text{if } x \geq 0 \\ x^2, & \text{if } x < 0 \end{cases}$

b $f(x) = \begin{cases} \frac{1}{2^x+1}, & \text{if } x \leq 1 \\ \frac{1}{x+2}, & \text{if } x > 1 \end{cases}$

c $f(x) = \begin{cases} \log \frac{1}{x^2+1}, & \text{if } x < 3 \\ \log \frac{1}{x+3}, & \text{if } x \geq 3 \end{cases}$

Find the gradient (slope) of the given curve at the given point in Exercises 55 – 67 below.

- 55** $f(x) = x^2 - 5x + 1; x = 1$ **56** $f(x) = x\sqrt{x+1}; x = 0$
57 $f(x) = \frac{x}{x+2}; x = 1$ **58** $f(x) = (x^2-1)\sqrt{x}; x = 2$
59 $f(x) = x^2 + 5x + 4; x = -2.5$ **60** $f(x) = x^3 - 3x + 1; x = 2$
61 $f(x) = \frac{3x-1}{(x-1)^2}; x = \frac{1}{2}$ **62** $f(x) = x^2 + \frac{2}{x^2}; x = \sqrt{2}$
63 $f(x) = e^{\sqrt{x^2+1}}; x = \sqrt{3}$ **64** $f(x) = \ln(x + \sqrt{x^2+1}); x = 1$

$$65 \quad f(x) = \cos(4x + 1); \quad x = \frac{\pi - 1}{4} \qquad 66 \quad f(x) = |3x - 2|; \quad x = \frac{2}{3}$$

$$67 \quad f(x) = \begin{cases} x^3, & \text{if } x \leq -1 \\ 3x + 2, & \text{if } x > -1 \end{cases}; \quad x = -1$$

For Exercises 68 – 79, find the equation of the line tangent to the given curve at the given point.

$$68 \quad f(x) = x^2 - 2x + 3; \quad x = -1$$

$$69 \quad f(x) = x\sqrt{x}; \quad x = 1$$

$$70 \quad f(x) = \frac{x}{x^2 + 1}; \quad x = 2$$

$$71 \quad f(x) = \sqrt{4 - 3x}; \quad x = -4$$

$$72 \quad f(x) = \sin x; \quad x = \frac{\pi}{3}$$

$$73 \quad f(x) = 3 - |x - 1|; \quad x = 1$$

$$74 \quad f(x) = \sqrt{9 - x^2}; \quad x = 2$$

$$75 \quad f(x) = \log(x + 3); \quad x = 7$$

$$76 \quad f(x) = e^{x+1}; \quad x = -2$$

$$77 \quad f(x) = \frac{\ln x}{x}; \quad x = e$$

$$78 \quad f(x) = \frac{1}{(x-2)^2}; \quad x = 1$$

$$79 \quad f(x) = \frac{e^x \sin x}{e^x + 1}; \quad x = 0$$

80 Find the equation of the line tangent to the graph of $y = x^2 - 5x + 1$ at the point where the curve crosses the line $y = 7$.

81 Find the equation of the tangent to the curve $y = \frac{1}{x} + x^2$ which has a slope of -3 .

82 Find the value of k so that the line $y = -8x + k$ is tangent to the curve $y = 3x^2 + 4x + 1$.

In Exercises 83 – 96, find $\frac{d^2y}{dx^2}$.

$$83 \quad y = x^2$$

$$84 \quad y = x^9$$

$$85 \quad y = (x^2 + 5)^7$$

$$86 \quad y = e^{1-x}$$

$$87 \quad y = \frac{1}{4}x^7 - 2x^3 + x^2 - 1$$

$$88 \quad y = \frac{1}{\sqrt{x}}$$

$$89 \quad y = \ln(x^2 + 1)$$

$$90 \quad y = \sin(x - \cos(x))$$

$$91 \quad y = e^x \cos x$$

$$92 \quad y = e^{-2x} \cos x$$

$$93 \quad y = \frac{2x-3}{2x+3}$$

$$94 \quad y = \frac{x^2+8}{x+1}$$

$$95 \quad y = (\sqrt{x+3} + 5)^{10}$$

$$96 \quad y = (x^2 + 1) \sin(4x + 5) \qquad 97 \quad \text{If } y = x^3 e^{-x}, \text{ find } \frac{d^3y}{dx^3}$$

$$98 \quad \text{If } f(x) = e^x \ln x, \text{ evaluate } f''(1).$$

Unit

4

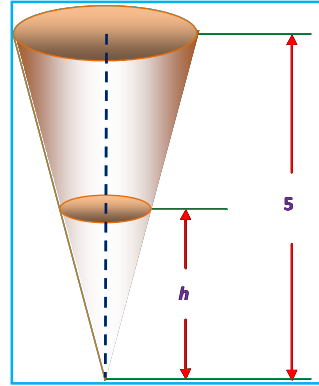

APPLICATIONS OF DIFFERENTIAL CALCULUS

Unit Outcomes:

After completing this unit, you should be able to:

- *find local maximum or local minimum value of a function on a given interval.*
- *find absolute maximum or absolute minimum value of a function on a given interval.*
- *apply the mean– value theorem.*
- *solve simple problems in which the studied theorems, formulae and procedures of differential calculus are applied.*
- *solve application problems.*

Main Contents

- 4.1 EXTREME VALUES OF FUNCTIONS**
- 4.2 MINIMIZATION AND MAXIMIZATION PROBLEMS**
- 4.3 RATE OF CHANGE**

Key terms

Summary

Review Exercises

INTRODUCTION

In **Unit 3** you have studied derivatives and have developed methods to find derivatives. Derivatives can have different interpretations in each of the sciences (natural and social).

For instance; the velocity of a particle is the rate of change of displacement with respect to time. Chemists who study a chemical reaction may be interested in the rate of change in the concentration of a reactant with respect to time called the rate of reaction. A steel manufacturer is interested in the rate of change of the cost of producing x tons of steel per day with respect to x (called the marginal cost). A biologist is interested in the rate of change of the population of a colony of bacteria with respect to time. In fact, the computation of rates of change is important in all of the natural sciences, in engineering, and even in the social sciences. All these rates of change can be interpreted as slopes of tangents. This gives added significance to the solution of the tangent problem. Whenever we solve a problem involving tangent lines, we are not just solving a problem in geometry. We are also implicitly solving a great variety of problems involving rates of change in science and engineering.

Once you have developed the properties of the mathematical concept once and for all, you can then turn around and apply these results to all of the sciences. This is much more efficient than developing properties of special concepts in each separate science. The French mathematician Joseph Fourier (1768 – 1830) put it briefly: "Mathematics compares the most diverse phenomena and discovers the secret analogies that unite them."

You have already investigated some of the applications of derivatives, but now that you know the differentiation rules, you are in a better position to pursue the applications of differentiation in greater depth. You will learn how derivatives affect the shape of the graph of a function and, in particular, how this helps you locate maximum and minimum values of functions. Many practical problems require us to minimize a cost or maximize an area or somehow find the best possible outcome of a situation.



OPENING PROBLEM

A square sheet of cardboard whose area is 12 m^2 is used to make an open box by cutting squares of equal size from the four corners and folding up the sides. What size squares should be cut to obtain a box with largest possible volume?

4.1 EXTREME VALUES OF FUNCTIONS

4.1.1 Revision on Zeros of Functions

The fundamental theorem of algebra states that every n^{th} degree polynomial has at most n real zeros. The problem of finding zeros of a polynomial is equivalent to the problem of factorizing the polynomial into linear or quadratic factors. In the earlier grades, you have studied how to find the zeros of a function, to refresh your memory, consider the following revision questions.

Note that a number c is a zero of a function f , if and only if $f(c) = 0$.

Revision Exercises

- Find the real zeros of each of the following functions.

a $f(x) = 3x - 2$	b $f(x) = x^3 - 8$	c $f(x) = x^3 + 8$
d $g(x) = \frac{1 - \sqrt{x}}{(x + 1)^2}$	e $g(x) = \sqrt{x - 1} + x - 1$	
f $h(x) = 7x^2 - 51x + 14$	g $h(x) = \frac{x^2 - 8x + 7}{x^2 + 1}$	
- Find x -intercept(s) of the graph of each of the following functions

a $y = 3 - 2x$	b $y = \frac{x - 1}{3x + 1}$	c $y = \sqrt{1 - x}$
d $y = x^2 - 4$	e $y = \frac{x^2 + x - 6}{x^2 + 4}$	f $y = x^4 + 1$
g $y = x^2 + 1$		
- Explain ways of finding zeros of functions. Consider particular cases such as linear and quadratic functions and other polynomials.

4.1.2 Critical Numbers and Critical Values

Maximum and minimum values of functions

One of the principal goals of calculus is to investigate the behavior of various functions. As part of this investigation, you will be laying the groundwork for solving a large class of problems that involve finding the maximum or minimum value of a function, if it exists. Such problems are often called optimization problems. You will be introduced some useful terminology, but before that do the following **Activity**.

ACTIVITY 4.1



- 1 Given a set $S = \{0, 1, 2, 3, 4, 5\}$ and $f(x) = 2x + 3$
 - a Find $S' = \{f(x) \mid x \in S\}$
 - b What is the largest element of S' ?
 - c What is the smallest element of S' ?
- 2 Given a set S as an open interval: $S = (0, 5)$ and $f(x) = 2x + 3$
 - a Find $S' = \{f(x) \mid x \in S\}$
 - b Can we list all the elements of S' ?
 - c Can you guess the largest element of S' ?
 - d Can you guess the smallest element of S' ?
- 3 Given a set S as a closed interval: $S = [0, 5]$ and $f(x) = 2x + 3$
 - a Find $S' = \{f(x) \mid x \in S\}$
 - b Can we list all the elements of S' ?
 - c Can you guess the largest element of S' ?
 - d Can you guess the smallest element of S' ?
- 4 Let $f(x) = \frac{1}{x}$. Find the largest and smallest elements, if each one of them exists on the following intervals.

a $(0, 5)$	b $(0, 5]$
c $[0, 5)$	d $[-1, 5]$

Now the above discussion leads to the following definition.

Definition 4.1

Let f be a function defined on set S .

If for some c in S

$f(c) \geq f(x)$ for every x in S , then $f(c)$ is called an **absolute maximum** of f on S .

If $f(c) \leq f(x)$ for every x in S , then $f(c)$ is called an **absolute minimum** of f on S .

The absolute maximum and absolute minimum of f on S are called **extreme values** or the **absolute extreme values** of f on S .

Sometimes we just use the terms maximum and minimum instead of absolute maximum and absolute minimum, if the context is clear.

Note that from **Definition 4.1** and **Activity 4.1**, a function does not necessarily have extreme values on a given set.

For instance,

- 1 $f(x) = 2x + 3$ which is continuous on $(0, 5)$ has no maximum value and minimum value (See **Activity 4.1** above).
- 2 $f(x) = \frac{1}{x}$ is not continuous on $[-1, 5]$ and has no maximum and minimum value.
- 3 $f(x) = 2x + 3$ has a maximum value on $(0, 5]$ which is 13 but has no minimum value.
- 4 $f(x) = 2x + 3$ has a minimum value on $[0, 5)$ which is 3 but has no maximum value on $[0, 5)$.

At this point one can ask how one can be sure whether a given function f has maximum and minimum values on a given interval.

Actually, if a function f is continuous on a closed bounded interval, it can be shown that both the absolute maximum and absolute minimum must occur. This result, called the **extreme value theorem**, plays an important role in the application of derivatives.

Extreme-value theorem

Let a function f be continuous on a closed, bounded interval $[a, b]$. Then f has both the absolute maximum and absolute minimum values on $[a, b]$.

To illustrate this theorem, let's consider the following graph of a function on the interval $[a, b]$.

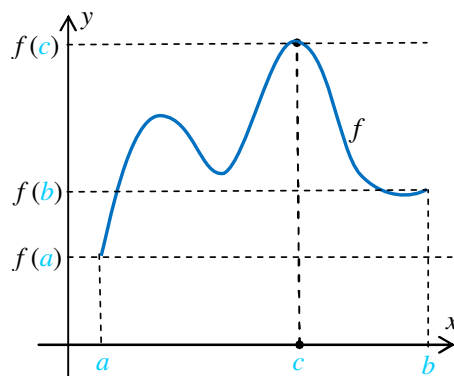

Figure 4.1

From the graph one can see that $f(a) \leq f(x) \leq f(c)$ for all x in $[a, b]$

Hence $f(a)$ is the absolute minimum and $f(c)$ is the absolute maximum value of f on $[a, b]$.

Note that this theorem does not tell us where and how to find the maximum and minimum values on $[a, b]$; it simply asserts that a continuous function on a closed and bounded interval has extreme values.

In the next section, you will see how and where to find the maximum and minimum value of f on $[a, b]$. To this end, we need to define relative extreme values and critical numbers.

Sometimes there are extreme values even when the conditions of the theorem are not satisfied, but if the conditions hold, the existence of extreme value is guaranteed.

Note that the maximum value of a function occurs at the highest point on its graph and the minimum value occurs at the lowest point.

Relative extreme values and critical numbers

Consider the following graph of a function f and answer the questions in **Activity 4.2** below.

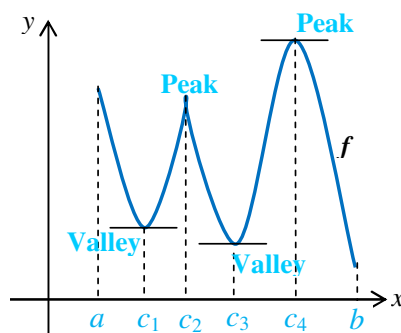

Figure 4.2

ACTIVITY 4.2



Identify the numbers at which the maximum or minimum values occur on the given interval.

- a** $[a, c_2]$ **b** $[a, c_4]$ **c** $[c_2, c_4]$ **d** $[a, b]$

Observe from the above **Activity** that, the extrema of a continuous function occur either at end points of the interval or at points where the graph has a "peak" or a "valley" (points where the graph is higher or lower than all nearby points).

For example, the function f in the above **Figure 4.2** has peaks at $(c_2, f(c_2))$, $(c_4, f(c_4))$ and valleys at $(c_1, f(c_1))$, $(c_3, f(c_3))$. Peaks and valleys are what you call relative extrema.

Definition 4.2

A function f is said to have a relative

- a** maximum at a number c in an open interval I , if $f(c) \geq f(x)$ for all x in I .
- b** minimum at a number c in an open interval I , if $f(c) \leq f(x)$ for all x in I .

The relative maxima and relative minima are called **relative extrema**.

Example 1 As shown in the above **Activity**, the valleys and peaks are relative minimum and relative maximum points respectively;

$f(c_1)$ and $f(c_3)$ are relative minimum values obtained at the valleys $(c_1, f(c_1))$ and $(c_3, f(c_3))$, respectively.

$f(c_2)$ and $f(c_4)$ are relative maximum values obtained at the peaks $(c_2, f(c_2))$ and $(c_4, f(c_4))$ respectively.

Observe that:

1 At $(c_1, f(c_1))$, $(c_3, f(c_3))$ and $(c_4, f(c_4))$ there are horizontal tangent lines, and hence the slope of the tangent line is zero there.

Thus $f'(c_1) = 0$, $f'(c_3) = 0$ and $f'(c_4) = 0$.

2 No tangent line can be drawn at $(c_2, f(c_2))$ and hence the derivative of f does not exist at c_2 .

Therefore, from **Observations 1** and **2**, one can conclude that relative extrema of a function occur either where the derivative is zero (horizontal tangent) or where the derivative does not exist (no tangent). This notion leads to the following conclusion:

Theorem 4.1

If a continuous function f has a relative extremum at c , then either $f'(c) = 0$ or f has no derivative at c .

Does the converse hold true? Justify by an example.

Definition 4.3

Let c be in the domain of f . Then if $f'(c) = 0$ or f has no derivative at c , then c is said to be a **critical number** of f .

Example 2 Find the critical numbers of the given functions

1 $f(x) = 4x^3 - 5x^2 - 8x + 20$ **2** $f(x) = 2\sqrt{x}(6 - x)$

Solution

1 $f'(x) = 12x^2 - 10x - 8$ is defined for all values of x .

Solve $12x^2 - 10x - 8 = 0$

$\Rightarrow 2(3x - 4)(2x + 1) = 0 \Rightarrow 3x - 4 = 0$ or $2x + 1 = 0 \Rightarrow 3x = 4$ or $2x = -1$

$\Rightarrow x = \frac{4}{3}$ or $x = -\frac{1}{2}$

Hence the critical numbers are $\frac{4}{3}$ and $-\frac{1}{2}$.

2 $f'(x) = 6x^{-\frac{1}{2}} - 3x^{\frac{1}{2}}$

The derivative is not defined at $x = 0$; but 0 is in the domain of f . Hence, 0 is a critical number.

To find other critical numbers (if they exist), solve $f'(x) = 0$.

$$\Rightarrow 6x^{\left(-\frac{1}{2}\right)} - 3x^{\frac{1}{2}} = 0 \Rightarrow 3x^{\left(-\frac{1}{2}\right)} (2 - x) = 0 \Rightarrow 2 - x = 0 \Rightarrow x = 2$$

Therefore, the critical numbers are 0 and 2.

Suppose you are looking for the absolute Extreme of a continuous function f on the closed and bounded interval $[a, b]$. Extreme Value Theorem tells you that these extrema exist and Theorem 4.1 enables you to narrow the list of "candidates" for points where extrema can occur from the entire interval $[a, b]$ to just the end points, and the critical numbers between a and b . This suggests the following procedures:

To find the absolute extrema of a continuous function f on $[a, b]$:

Step 1 Compute $f'(x)$ and find critical numbers of f on (a, b)

Step 2 Evaluate f at the endpoints a, b and at each critical number.

Step 3 Compare the values in **Step 2**.

Thus by comparing the values of f in step 3 you have:

- ✓ the largest value of f is the absolute maximum of f on $[a, b]$
- ✓ the smallest value of f is the absolute minimum of f on $[a, b]$

Example 3 Given $f(x) = x^2 - x^3$, find the absolute extremum value of f on

- a** $[-1, 2]$ **b** $\left[-\frac{1}{2}, \frac{3}{2}\right]$ **c** $[0, 1]$

Solution $f'(x) = 2x - 3x^2, f'(x) = 0 \Rightarrow x(2 - 3x) = 0 \Rightarrow x = 0$ or $x = \frac{2}{3}$

- a** Both 0 and $\frac{2}{3}$ are critical numbers on $[-1, 2]$

Hence the following are the candidates for extreme values.

$$f(0) = 0, f\left(\frac{2}{3}\right) = \frac{4}{27}, f(-1) = 2, f(2) = -4$$

Comparing the values, the maximum value is 2 and the minimum value is -4 .

b Both 0 and $\frac{2}{3}$ are critical numbers on $\left[-\frac{1}{2}, \frac{3}{2}\right]$. Hence, $f(0)$, $f\left(\frac{2}{3}\right)$,

$f\left(-\frac{1}{2}\right)$ and $f\left(\frac{3}{2}\right)$ are candidates for extreme values.

$$f(0) = 0, f\left(\frac{2}{3}\right) = \frac{4}{27}; f\left(-\frac{1}{2}\right) = \frac{3}{8}; f\left(\frac{3}{2}\right) = \frac{-9}{8}$$

Comparing the values, $\frac{3}{8}$ is the maximum value and $-\frac{9}{8}$ is the minimum value.

c $\frac{2}{3}$ is the only critical number in $[0,1]$, hence $f(0)$, $f\left(\frac{2}{3}\right)$ and $f(1)$ are the candidates for extreme values.

$$f(0) = 0, f\left(\frac{2}{3}\right) = \frac{4}{27} \text{ and } f(1) = 0$$

Comparing the values 0 is the minimum value and $\frac{4}{27}$ is the maximum value.

Example 4 Find the absolute maximum and minimum value of $f(x) = x - x^{\frac{2}{3}}$ on $[-1, 2]$.

Solution $f'(x) = 1 - \frac{2}{3}x^{-\frac{1}{3}} = \frac{3x^{\frac{1}{3}} - 2}{3x^{\frac{1}{3}}}$ but $f'(0)$ does not exist.

Hence 0 is one of the critical numbers.

$$f'(x) = 0 \Rightarrow \frac{3}{2}x^{\frac{1}{3}} - 1 = 0 \Rightarrow x = \left(\frac{3}{2}\right)^3 = \frac{8}{27} \Rightarrow x = 0 \text{ and } x = \frac{8}{27}$$

are critical numbers.

Hence the following are the candidates for extreme values:

$$f(-1) = -2, f(2) = 2 - \sqrt[3]{4} > 0, f(0) = 0, f\left(\frac{8}{27}\right) = \frac{-4}{27}$$

Therefore -2 is the minimum value and $2 - \sqrt[3]{4}$ is the maximum value on $[-1, 2]$.

Exercise 4.1

Identify critical numbers and find the absolute maximum value and absolute minimum value for each of the given functions on the given interval.

1 $f(x) = x^3; [-2, 1]$

2 $f(x) = x^4 - 2x^2 + 3; [-1, 2]$

3 $f(x) = x^{\frac{2}{3}}(5 - 2x); [-1, 2]$

4 $f(x) = 2\cos x + x; [0, 2\pi]$

5 $f(x) = x^3 - 3x^2; [-1, 3]$

6 $f(x) = 3x^5 - 20x^3; [-2, 2]$

Rolle's theorem and the mean-value theorem

You will see that many of the results of this unit depend on one central fact, which is called the **mean-value theorem**. But to arrive at the **mean-value theorem** you begin with a special case of the **mean-value theorem** called **Rolle's theorem**, named after the seventeenth-century French mathematician **Michael Rolle**. This result implies that if f is continuous on $[a, b]$ and $f(a) = f(b)$ then there always exists at least one critical number of f in (a, b) .

ACTIVITY 4.3

Look at the following graphs and answer the questions below:

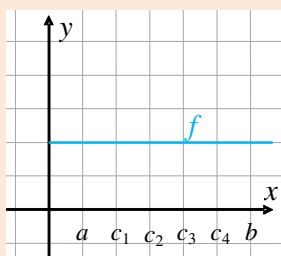

i

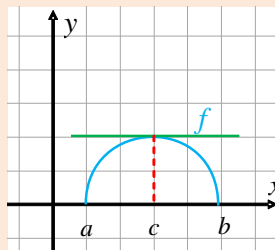

ii

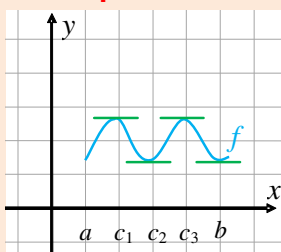

iii

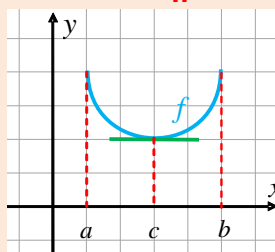

iv

Figure 4.3

In all cases $f(a) = f(b)$

- 1** Find the coordinates of points on each graph at which horizontal tangent lines occur.
- 2** What is the slope of a horizontal line?
- 3** How do you relate slopes of tangent lines to derivatives?

Rolle's theorem

Let f be function that satisfies the following three conditions:

- a** f is continuous on the closed interval $[a, b]$
- b** f is differentiable on the open interval (a, b)
- c** $f(a) = f(b)$

Then, there is a number c in (a, b) such that $f'(c) = 0$

Proof: There are three cases:

Case 1 $f(x) = k$, a constant (as in **Figure 4.3i** in the above activity)

Then $f'(x) = 0$, so the number c can be any number in (a, b)

Case 2 $f(x) > f(a)$ for some x in (a, b) , (as in **Figure 4.3ii** and **Figure 4.3iii** in the above **Activity**)

By the **extreme value theorem**, f has a maximum value somewhere in $[a, b]$. Since $f(a) = f(b)$, it must attain this maximum value at a number c in (a, b) . Then f has a local maximum at c and, since f is differentiable at c , this implies that $f'(c) = 0$

Case 3 $f(x) < f(a)$ for some x in (a, b) (as in **Figure 4.3 iii** and **Figure 4.3 iv** in the above **Activity**)

By the **extreme value theorem**, f has a minimum value in $[a, b]$ and, since $f(a) = f(b)$, it attains this minimum value at a number c in (a, b) where again $f'(c) = 0$.

Example 5 Let's apply **Rolle's theorem** to the position function $f(t)$ of a moving object. If the object is in the same place at two different instant $t = a$ and $t = b$, then $f(a) = f(b)$. **Rolle's theorem** says that there is some instant of time $t = c$ between a and b when $f'(c) = 0$; that is, the velocity is 0. (In particular you can see that this is true when a ball is thrown directly upward).

Example 6 Prove that the equation $x^3 + x - 1 = 0$ has exactly one real root.

Solution First you use the intermediate value theorem to show that a root exists.

$$\text{Let } f(x) = x^3 + x - 1 \quad f(0) = -1 < 0 \quad \text{and} \quad f(1) = 1 > 0$$

Since f is a polynomial, it is continuous, so the intermediate value theorem states that there is a number c between 0 and 1 such that $f'(c) = 0$. Thus the given equation has a root.

To show that the equation has no other real root, we use **Rolle's theorem** and argue by contradiction.

Suppose that it had two real roots a and b . Then $f(a) = f(b) = 0$ and, since f is a polynomial, it is differentiable on (a, b) and continuous on $[a, b]$. Thus by **Rolle's theorem**, there is a number c between a and b such that $f'(c) = 0$.

$$\text{But } f'(x) = 3x^2 + 1 \geq 1 \quad \forall x \quad (\text{Since } x^2 \geq 0)$$

So $f'(x) \neq 0$. This leads to a contradiction.

Therefore, the equation cannot have two real roots.

Our main use of **Rolle's theorem** is in proving another important theorem, which was first stated by French mathematician, **Joseph – Louis Lagrange**.

ACTIVITY 4.4



Consider the following graphs.

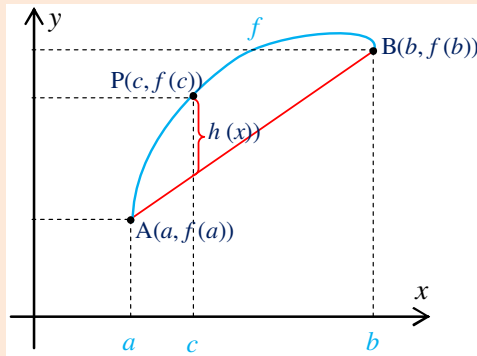

Figure 4.4

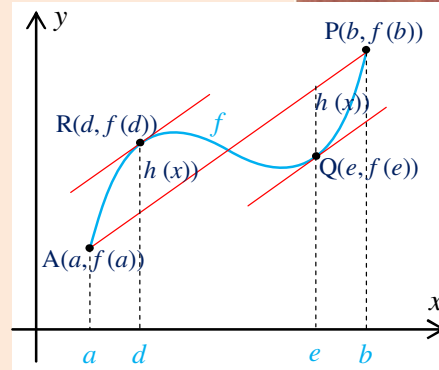

Figure 4.5

In both cases AB and AP are the secant lines of the graph of f .

- a** Find the slope of the secant line AB .
- b** Find the equation of the secant line.
- c** Can you draw a line parallel to AB and passing through P ? Why?
- d** Can you draw a line parallel to AB and passing through R ? Q ? Why?
- e** Recall that the lines through P , R , Q are tangent lines. Can you find the slope of these tangent lines, if f is a differentiable function? Explain.
- f** For the tangents parallel to AB , compare the slope with that of the slope of AB . Are these equal? Why?
- g** Can you find the vertical distance $h(x)$ as in **Figure 4.4** and **Figure 4.5**?

The mean-value theorem

Let f be a function that satisfies the following conditions:

- 1** f is continuous on the closed interval $[a, b]$
- 2** f is differentiable on the open interval (a, b)

Then there is a number c in (a, b) such that

$$f'(c) = \frac{f(b) - f(a)}{b - a} \text{ or equivalently } f(b) - f(a) = f'(c)(b - a)$$

Proof: Using **Activity 4.4**

$$h(x) = f(x) - y, \text{ where } y = \left(\frac{f(b) - f(a)}{b - a} \right) (x - a) + f(a)$$

$$h(a) = 0 = h(b) \text{ and } \frac{dy}{dx} = \frac{f(b) - f(a)}{b - a}$$

Observe that h is continuous on $[a, b]$ and differentiable on (a, b) . Then by **Rolle's theorem** there is a number c in (a, b) such that $h'(c) = 0$

$$\Rightarrow f'(c) - \left. \frac{dy}{dx} \right|_{x=c} = 0 \Rightarrow f'(c) = \left. \frac{dy}{dx} \right|_{x=c} \Rightarrow f'(c) = \frac{f(b) - f(a)}{b - a}$$

Example 7 To illustrate the **mean-value theorem** with a specific function, consider $f(x) = x^3 - x$, $a = 0$, $b = 2$. Since f is a polynomial, it is continuous and differentiable for all $x \in \mathbb{R}$, so it is certainly continuous on $[0, 2]$ and differentiable on $(0, 2)$. Therefore, by the **mean-value theorem**, there is a number c in $(0, 2)$ such that

$$f(2) - f(0) = f'(c)(2 - 0), \quad f(2) = 6, f(0) = 0$$

$$f'(x) = 3x^2 - 1$$

$$f'(c) = 3c^2 - 1$$

$$\Rightarrow 6 = (3c^2 - 1)(2) = 6c^2 - 2$$

$$\Rightarrow c^2 = \frac{4}{3} \Rightarrow c = \pm \frac{2}{\sqrt{3}}$$

But c must lie in $(0, 2)$, so $c = \frac{2}{\sqrt{3}}$

- 2** If an object moves in a straight line with position function $f(t)$, then the average velocity between $t = a$ and $t = b$ is $\frac{f(b) - f(a)}{b - a}$ and the velocity at $t = c$ is $f'(c)$.

Thus, the **mean-value theorem** tells us that at a time $t = c$ between a and b the instantaneous velocity $f'(c)$ is equal to that of the average velocity. For instance, if a car travelled 180 km in 2 hrs, then the speedometer must have read 90 km/hr at least once.

The **Mean-value theorem** can be used to establish some of the basic facts of differential calculus.

Theorem 4.2

If $f'(x) = 0$ for all x in an interval I , then f is a constant on I .

Proof: Let f be a differentiable function on an interval I and let

$$f'(x) = 0 \text{ for all } x \text{ on interval } I$$

If $x_1, x_2 \in I$ and $x_1 < x_2$ with $f'(x) = 0 \forall x \in I$

The function satisfies the conditions of **mean-value theorem** on $[x_1, x_2]$. *Why?*

Thus we apply **mean-value theorem** on $[x_1, x_2]$; so, that

$$f(x_2) - f(x_1) = f'(c)(x_2 - x_1) = 0. \text{ Why?}$$

This implies that $f(x_1) = f(x_2) \forall x_1, x_2 \in I$

Therefore; we conclude that f is a constant on I .

Corollary 4.1

If $f'(x) = g'(x)$ for all x on an interval I , then $f - g$ is a constant or

$$f(x) = g(x) + c, \text{ (} c \text{ is arbitrary constant.)}$$

Proof: Exercise

(Hint: consider $(f - g)'(x) = 0 \forall x$ and apply the above theorem)

Exercise 4.2

1 Verify that each of the following functions satisfies the three conditions of **Rolle's theorem** on the given interval. Then, find all values of c that satisfy the conclusion of **Rolle's theorem**.

a $f(x) = x^2 - 4x + 1$ on $[0, 4]$ **b** $f(x) = x^3 - 3x^2 + 2x + 5$ on $[0, 2]$

c $f(x) = \sin 2\pi x$ on $[-1, 1]$ **d** $f(x) = x\sqrt{x+6}$ on $[-6, 0]$

2 Given $f(x) = 1 - x^{\frac{2}{3}}$, show that $f(1) = f(-1)$ but there is no c in $(-1, 1)$ such that $f'(c) = 0$. Why does this not contradict **Rolle's theorem**?

3 Repeat **Question 2** for

$$f(x) = (x - 1)^{-2}, f(0) = f(2) \text{ on } [0, 2]$$

4 Verify that the following functions satisfy the conditions of the **mean-value theorem** on the given interval. Then find all values of c that satisfy the conclusion of the **Mean-value theorem**.

a $f(x) = 3x^2 + 2x + 5, [-1, 1]$ **b** $f(x) = x^3 + x - 1, [0, 2]$

c $f(x) = \sqrt[3]{x}, [0, 1]$ **d** $f(x) = \frac{x}{x+2}, [1, 4]$

5 Let $f(x) = |x - 1|$.

Show that there is no value of c such that $f(3) - f(0) = f'(c)(3 - 0)$.

Why does this not contradict the **mean-value theorem**?

6 Show that the equation $x^5 + 10x + 3 = 0$ has exactly one real root.

Increasing and decreasing functions

Under this subtopic you consider intervals on which the graph of a function rises, falls or a constant, and attach a meaning to it. To do this, consider the following **Activity**.

ACTIVITY 4.5



- 1 Consider the graph of the following function.

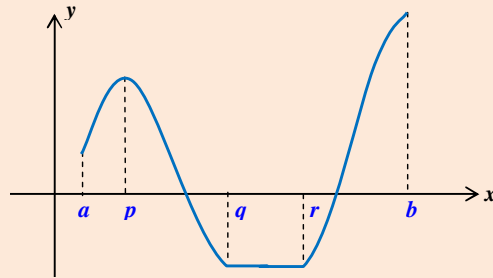

Figure 4.6

- a** Discuss whether the graph of f is rising or falling as you move from left to right starting at a .
- b** Identify the intervals in which the graph is rising and falling.
- c** Identify the intervals in which the graph is neither raising nor falling.
- 2 Again considering the graph of f in Question 1 above,
- a** If $x_1 < x_2$ on $[a, p]$, is it true that $f(x_1) < f(x_2)$?
- b** If $x_1, x_2 \in [p, q]$ and $x_1 < x_2$, which of the following is true?
i $f(x_1) < f(x_2)$. **ii** $f(x_1) > f(x_2)$.
- c** If $x_1, x_2 \in [q, r]$; and $x_1 < x_2$, which one of the following is true?
i $f(x_1) < f(x_2)$ **ii** $f(x_1) > f(x_2)$ **iii** $f(x_1) = f(x_2)$
- d** Take $x_1, x_2 \in [r, b]$ with $x_1 < x_2$, compare the values $f(x_1)$ and $f(x_2)$.

Now as a summary of the above **Activity**, you have the following definition.

Definition 4.4

Let f be a function on an interval I .

- i** If for any x_1, x_2 in I , $x_1 < x_2$ implies $f(x_1) \leq f(x_2)$
 f is said to be **increasing** on I .
- ii** If for any x_1, x_2 in I , $x_1 < x_2$ implies $f(x_1) \geq f(x_2)$
 f is said to be **decreasing** on I .
- iii** If for any x_1, x_2 in I , $x_1 < x_2$ implies $f(x_1) < f(x_2)$
 f is said to be **strictly increasing** on I .
- iv** If for any x_1, x_2 in I , $x_1 < x_2$ implies $f(x_1) > f(x_2)$
 f is said to be **strictly decreasing** on I .

Example 8 By looking at the graph of the above **Activity 4.5**, identify the intervals in which f is increasing, decreasing, strictly increasing and strictly decreasing.

Solution

- i** On the intervals $[a, p]$ and $[r, b]$ f is strictly increasing.
- ii** On the interval $[p, q]$ f is strictly decreasing.
- iii** On the interval $[p, r]$ f is decreasing (but not strictly)
- iv** On the interval $[q, b]$ f is increasing. (but not strictly)

How derivatives affect the shape of a graph

Many applications of calculus depend on your ability to deduce facts about a function from information concerning its derivatives. Because $f'(x)$ represents the slope of the curve $y = f(x)$ at the point $(x, f(x))$, it tells you the direction in which the curve proceeds at each point. So it is reasonable to expect that information about $f'(x)$ will provide you with information about $f(x)$.

In the previous section you have seen that if $f'(x) = 0$ for each x in some interval I , then f is a constant on I . Now what do you conclude, if $f'(x) > 0$ for each x in I ; or if $f'(x) < 0$ for each x in I ?

ACTIVITY 4.6



Consider the following graph.

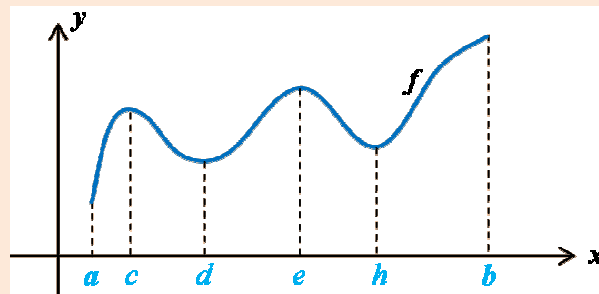

Figure 4.7

- 1** If x is any point in (a, c) , is $f'(x) > 0$ or $f'(x) < 0$? Why? (Hint: relate $f'(x)$ to the slope of tangents on (a, c) .)
- 2** Repeat it for any x in (c, d) , (d, e) , (e, h) and (h, b) . (Assume f is differentiable at c, d, e , and h .)

As a result of the discussion in **Activity 4.6**, you have the following test which is important in identifying the intervals in which a function is increasing or decreasing.

Increasing and decreasing test

Suppose that f is continuous on an interval I and differentiable in the interior of I .

- i** If $f'(x) \geq 0$ for all x in the interior of I , then f is increasing on I .
- ii** If $f'(x) \leq 0$ for all x in the interior of I , then f is decreasing on I .
- iii** If $f'(x) > 0$ and $f'(x) = 0$ only for finite number of points on I , then f is strictly increasing on I .
- iv** If $f'(x) < 0$ and $f'(x) = 0$ only for finite number of points on I , then f is strictly decreasing on I .

Example 9 Find where the function $f(x) = 3x^4 - 4x^3 - 12x^2 + 5$ is increasing and where it is decreasing.

Solution $f'(x) = 12x^3 - 12x^2 - 24x = 12x(x^2 - x - 2) = 12x(x - 2)(x + 1)$

You are going to find intervals in which $f'(x)$ is positive or negative. Use sign charts for this purpose, as follows:

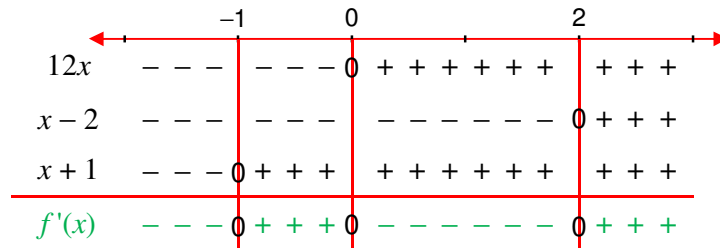

From the sign chart one can see that

- i** $f'(x) \geq 0$ on $[-1, 0]$ and $[2, \infty)$ and $f'(x) = 0$ only at $x = -1, 0$ and $x = 2$, thus f is strictly increasing on $[-1, 0]$ and $[2, \infty)$.
- ii** $f'(x) \leq 0$ on $(-\infty, -1]$ and $[0, 2]$ and $f'(x) = 0$ only at $x = -1, 0$ and 2 , thus f is strictly decreasing on $(-\infty, -1]$ and $[0, 2]$.

Exercise 4.3

Find intervals in which f is strictly increasing or strictly decreasing.

- | | |
|--|--|
| <p>1 $f(x) = x^3 - 12x + 1$</p> <p>3 $f(x) = x^3 - 3x^2 + 5$</p> <p>5 $f(x) = x^4 - 6x^2$</p> <p>7 $f(x) = x \sqrt{x^2 + 1}$</p> <p>9 $f(x) = x^{\frac{1}{3}} (x + 3)^{\frac{2}{3}}$</p> | <p>2 $f(x) = x - 2\sin x$ on $[0, 2\pi]$</p> <p>4 $f(x) = 2x^3 - 3x^2 + 5$</p> <p>6 $f(x) = 3x^5 - 5x^2 + 3$</p> <p>8 $f(x) = x \sqrt{x + 1}$</p> <p>10 $f(x) = x - 3x^{\frac{1}{3}}$</p> |
|--|--|

11 $f(x) = (x^2 - 1)^3$

12 $f(x) = \frac{x - 1}{x^2 + 8}$

13 $f(x) = xe^x - 4$

14 $f(x) = 3 + |x|$

15 $f(x) = \frac{x^2}{x - 4}$

16 $f(x) = |x - 3| - 5$

17 $f(x) = 2 - 3^{1-2x}$

18 $f(x) = \ln(3 - 2x)$

19 $f(x) = e^{x^2-1}$

20 $f(x) = |\ln x|$

Local extreme values of a function on its entire domain

Recall that if f has a local maximum or minimum at c , then c must be a critical number of f ; but not every critical number gives rise to a maximum or a minimum. You therefore need a test that will tell you whether or not f has a local maximum or minimum at a critical number.

Suppose f is continuous on an interval $[a, b]$ and $a < c < b$ such that f is strictly increasing on $[a, c]$ and f is strictly decreasing on $[c, b]$ as in **Figure 4.8**:

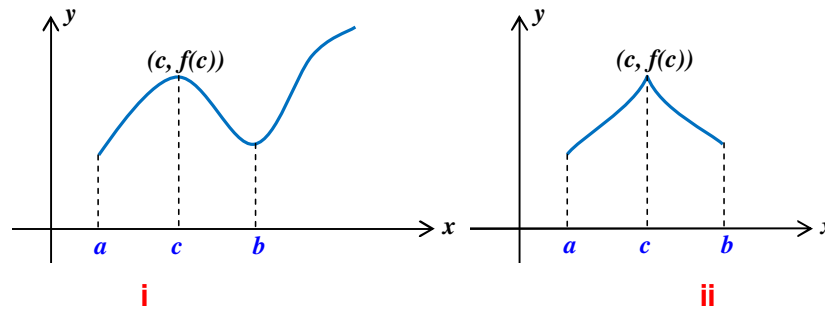

Figure 4.8

From **Figure 4.8** it is clear that

$$f(c) \geq f(x) \quad \forall x \in [a, b].$$

Thus $f(c)$ is a local maximum value of f on (a, b)

Observe that:

$f'(x) > 0$ for every $x \in (a, c)$; and $f'(x) < 0$ for every $x \in (c, b)$ in both of the graphs of **Figure 4.8**. If f' satisfies the above conditions, you say that f' changes sign at c from positive to negative.

Again suppose f is continuous on an interval $[a, b]$ and $a < c < b$ such that f is strictly decreasing on $[a, c]$ and f is strictly increasing on $[c, b]$ as in the **Figure 4.9** below.

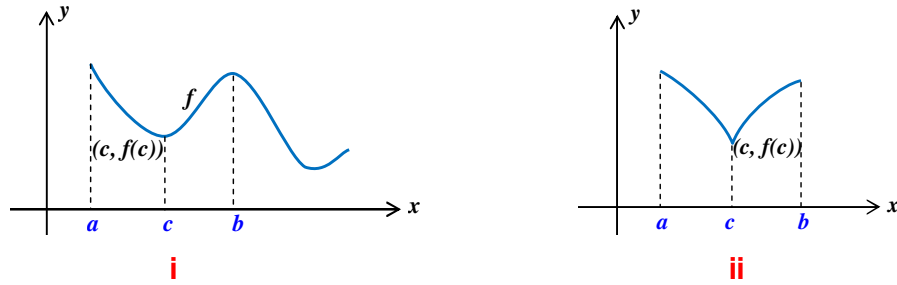

Figure 4.9

It is clear that $f(c) \leq f(x)$ for every $x \in (a, b)$ and hence f has a local minimum value at c .

Observe that:

$f'(x) < 0$ for every $x \in (a, c)$; and $f'(x) > 0$ for every $x \in (c, b)$ in both of the graphs in Figure 4.9. If f' satisfies the above conditions, you say that f' changes sign at c from negative to positive.

Therefore, you can have the following test for local extreme values of a function.

First derivative test for local extreme values of a function

Suppose that c is a critical number of a continuous function, then

- a** if f' changes sign from positive to negative at c , then f has a local maximum at c .
- b** if f' changes sign from negative to positive at c , then f has a local minimum at c .
- c** if f' does not change sign at c (that is, f' is positive on both sides of c or negative on both sides), then f has neither local maximum nor minimum at c .

Example 10 Find the local maximum and minimum values of the function:

1 $f(x) = 3x^4 - 4x^3 - 12x^2 + 5$ **2** $g(x) = x + 2 \sin x$ for $0 \leq x \leq 2\pi$

Solution

1 $f'(x) = 12x^3 - 12x^2 - 24x = 12x(x^2 - x - 2) = 12x(x - 2)(x + 1)$

From the sign chart in Example 9 one can see that

$$f'(x) \leq 0 \text{ on } (-\infty, -1] \text{ and } [0, 2] \text{ and } f'(x) = 0 \text{ only at } x = -1, 0 \text{ and } 2.$$

Thus, f is strictly decreasing on $(-\infty, -1]$ and $[0, 2]$.

- a** f' changes sign from negative to positive at -1 and 2
Hence both $f(-1) = 0$ and $f(2) = -27$ are local minimum value.
- b** f' changes sign from positive to negative at 0 and hence $f(0) = 5$ is the local maximum value.

2 $g'(x) = 1 + 2 \cos x$, $g'(x) = 0 \Rightarrow \cos x = -\frac{1}{2} \Rightarrow x = \frac{2\pi}{3}$ or $x = \frac{4\pi}{3}$ in $[0, 2\pi]$

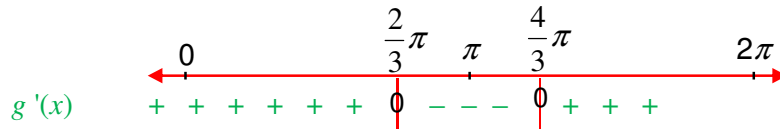

a g' changes sign from positive to negative at $\frac{2}{3}\pi$ and hence

$$g\left(\frac{2}{3}\pi\right) = \frac{2}{3}\pi + 2 \sin\left(\frac{2}{3}\pi\right) = \frac{2}{3}\pi + \sqrt{3} \text{ is a local maximum value.}$$

b g' changes sign from negative to positive at $\frac{4}{3}\pi$ and hence

$$g\left(\frac{4}{3}\pi\right) = \frac{4}{3}\pi + 2 \sin\frac{4}{3}\pi = \frac{4}{3}\pi - \sqrt{3} \text{ is a local minimum value.}$$

Exercise 4.4

- Find the local maximum and minimum values of each of the following functions.
- | | | |
|---|--|--|
| 1 $f(x) = x^2 - 12x + 1$ | 2 $f(x) = x^3 - 3x^2 + 5$ | 3 $f(x) = x - 2\sin x$ on $[0, 2\pi]$ |
| 4 $f(x) = \frac{x}{(1+x)^2}$ | 5 $f(x) = x^3 - \frac{3}{2}x^2$ | 6 $f(x) = x^3 - 12x$ |
| 7 $f(x) = (x^2 - 4)^{\frac{2}{3}}$ | 8 $f(x) = x^3 - 3x^2 + 3x$ | 9 $f(x) = -x^3 + 2$ |
| 10 $f(x) = 2x - 3x^{\frac{2}{3}}$ | | |

Concavity and inflection points

This subtopic focuses on the importance of the second derivative in identifying the shape of the curve.

In the previous section you have used the first derivative test for intervals of monotonicity and determining local maximum values and local minimum values. You will see now that the second derivative test is also important in the study of the behaviour of the graph of a function f .

Now consider the following two graphs of increasing functions f and g on $[a, b]$.

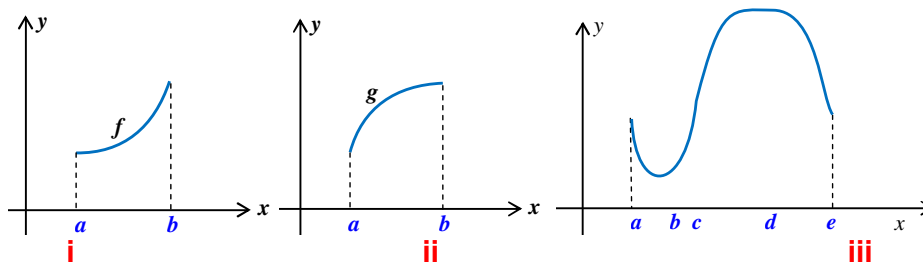

Figure 4.10

The graphs in i and ii of Figure 4.10 look different because they bend in different directions. You are going to see how to distinguish between these two types of behaviour. For this purpose, first try to do the following Activity.

ACTIVITY 4.7

- 1 Copy the curves in Figure 4.10 and try to draw tangents to the curves at several points between a and b .
- 2 Does the curve of f lie above the tangents or below?
- 3 Does the curve of g lie above the tangents or below?



Definition 4.5

If the graph of a function lies above all of its tangents on an interval I , then it is called **concave upward** on I .

If the graph of a function lies below all of its tangents on an interval I , then it is called **concave downward** on I .

Example 11 Consider the following graph.

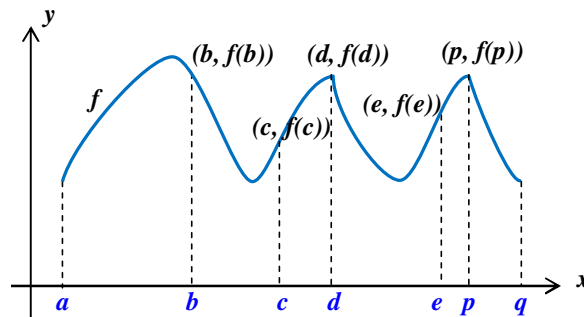

Figure 4.11

On the intervals (a, b) , (c, d) , (e, p) the graph is concave downward.

On the intervals (b, c) , (d, e) and (p, q) the graph is concave upward.

Note:

Points $(b, f(b))$, $(c, f(c))$, $(d, f(d))$, $(e, f(e))$ and $(p, f(p))$ are points on the graph at which concavity changes either from concave up to concave down or from concave down to concave up. Such types of points are called **inflection points**.

Definition 4.6

A point on a curve is called an **inflection point**, if the curve changes either from concave up to concave down or from concave down to concave up.

Now see how the second derivative helps to determine the intervals of concavity and inflection points.

Concavity test

Let f be a function which is twice differentiable on an interval I , then

- a** If $f''(x) > 0$ for all x in I , the graph of f is concave upward on I .
- b** If $f''(x) < 0$ for all x in I , the graph of f is concave downward on I .

Another application of the second derivative is the following test for maximum and minimum values. It is a consequence of the concavity test.

The second derivative test

Suppose f is twice differentiable and f'' is continuous at c

- a** If $f'(c) = 0$ and $f''(c) > 0$, then f has a local minimum at c .
- b** If $f'(c) = 0$ and $f''(c) < 0$, then f has a local maximum at c .

$f''(c) > 0$ near c and so f is concave upward near c . This means that the graph of f lies above its horizontal tangent at c and so f has a local minimum at c .

$f''(c) < 0$, near c and so f is concave downward near c . This means that the graph of f lies below its horizontal tangent at c and so f has a local maximum at c .

Example 12 Discuss the behaviour of the curve $f(x) = x^4 - 4x^3$ with respect to concavity, points of inflection, local maximum and minimum.

Solution $f'(x) = 4x^3 - 12x^2 \Rightarrow f'(x) = 4x^2(x - 3)$

Thus $f'(x) = 0 \Rightarrow 4x^2(x - 3) = 0 \Rightarrow x = 0$ or $x = 3$

Now $f''(x) = 12x^2 - 24x$, $f''(0) = 0$ and $f''(3) = 36 > 0$

Since $f'(3) = 0$ and $f''(3) = 36 > 0$, $f(3) = -27$ is a local minimum value by the second derivative test.

Since $f''(0) = 0$, the second derivative test gives no information about the critical number 0. But since $f'(x) < 0$ for $x < 0$ and also for $0 < x < 3$, the first derivative test tells us that f does not have a local extreme value at 0.

To determine intervals of concavity and inflection points we use the following sign chart:

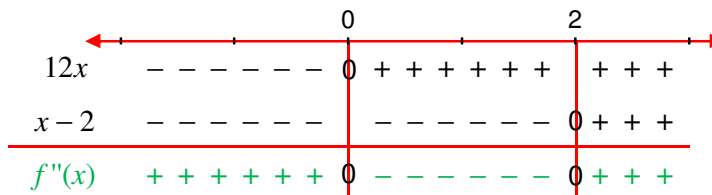

The points with coordinates $(0, 0)$ and $(2, -16)$ are inflection points.

The graph of f is concave upward on $(-\infty, 0)$ and $(2, \infty)$ and concave downward on $(0, 2)$.

Note:

The second derivative test is inconclusive when $f''(c) = 0$. In other words, at such a point there might be a maximum, there might be a minimum, or there might be neither. This test also fails when $f''(c)$ does not exist. In such cases, the first derivative test must be used. In fact, even when both tests apply, the first derivative test is often the easier one to use.

Example 13 Discuss the behaviour of the curve $f(x) = (x^{\frac{2}{3}})(6-x)^{\frac{1}{3}}$ with respect to

- a** monotonicity
- b** relative extreme values
- c** inflection points and concavity.

Solution
$$f'(x) = \left(\frac{2}{3}x^{-\frac{1}{3}}\right)(6-x)^{\frac{1}{3}} - x^{\frac{2}{3}} \frac{1}{3}(6-x)^{-\frac{2}{3}} = \frac{4-x}{x^{\frac{1}{3}}(6-x)^{\frac{2}{3}}}$$

$f'(x) = 0$ when $x = 4$ and $f'(x)$ does not exist when $x = 0$ or $x = 6$.

Hence, 0, 4 and 6 are critical numbers.

To identify the extreme value and intervals of monotonicity you use the sign chart.

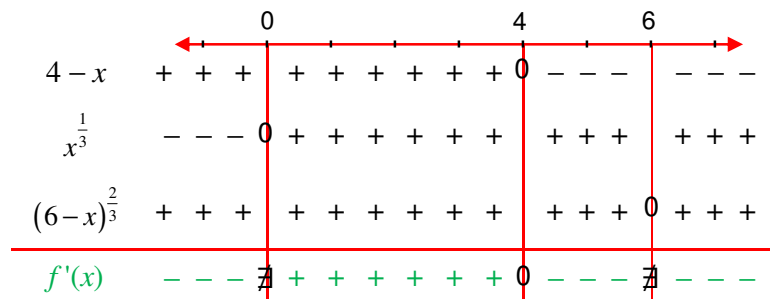

From the chart $f'(x) > 0$ on $(0, 4)$

Hence f is strictly increasing on $[0, 4]$.

$$f'(x) < 0 \text{ on } (-\infty, 0), (4, 6) \text{ and } (6, \infty)$$

Hence f is strictly decreasing on $(-\infty, 0]$ and $[4, \infty)$

f' changes sign from negative to positive at 0 and hence

$$f(0) = 0 \text{ is a local minimum value.}$$

f' changes sign from positive to negative at 4 and hence $f(4) = 2\sqrt[3]{4}$ is a local maximum value.

At $x = 6$, f' does not change sign and hence $f(6)$ is neither a local maximum value nor a local minimum value.

Now to check concavity and inflection points we make use of the second derivative.

$$f''(x) = \frac{-8}{x^{\frac{4}{3}}(6-x)^{\frac{5}{3}}}$$

f'' does not exist at $x = 0$ and $x = 6$

To determine concavity and inflection points consider the following chart.

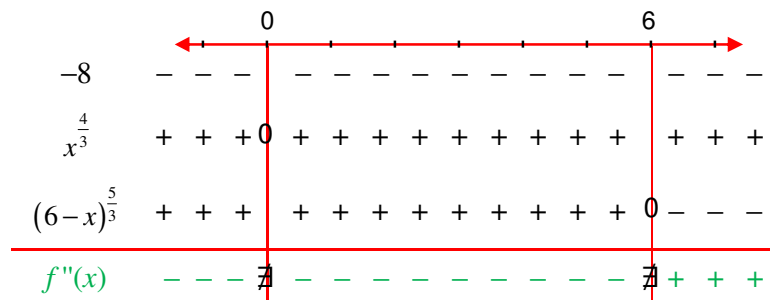

$f''(x) > 0$ on $(6, \infty)$.

Hence the graph of f is concave upward on $(6, \infty)$.

$f''(x) < 0$ on $(-\infty, 0)$ and $(0, 6)$.

Hence by the second derivative test the graph of f is concave downward on $(-\infty, 0)$ and $(0, 6)$.

f'' changes sign at $x = 6$, and hence $(6, f(6)) = (6, 0)$ is an inflection point.

Curve sketching

Now, you are ready to develop a procedure for curve sketching. To sketch the graph of a given function, we need to know where the graph crosses the x -axis, the y -axis, its turning points, and intervals in which the graph rises and falls.

Example 14 Sketch the graph of $f(x) = x^4 - 4x^3$.

Solution

- a** $f(x) = x^4 - 4x^3$ is a polynomial function and hence it is defined for all real numbers.
- b** y -intercept: it is the value of f at $x = 0$
 Thus y -intercept $= f(0) = 0^4 - 4(0^3) = 0$
 Hence the graph crosses the y -axis at $(0, 0)$

- c** x -intercept: it is the zero of the function $f(x)$.

Which means $x^4 - 4x^3 = 0$

$$\Rightarrow x^3(x - 4) = 0 \Rightarrow x^3 = 0 \text{ or } x - 4 = 0 \Rightarrow x = 0 \text{ or } x = 4$$

Therefore, $x = 0$ and $x = 4$ are the x -intercepts.

That means the graph of f crosses the x -axis at points $(0, 0)$ and $(4, 0)$.

- d** Intervals of monotonicity and relative extreme values

To identify intervals in which f is monotonic, you need to find the derivative of f and find critical numbers.

$$f(x) = x^4 - 4x^3 \Rightarrow f'(x) = 4x^3 - 12x^2$$

$$f'(x) = 0 \Rightarrow 4x^3 - 12x^2 = 0 \Rightarrow 4x^2(x - 3) = 0 \Rightarrow 4x^2 = 0 \text{ or } x - 3 = 0$$

$$\Rightarrow x = 0 \text{ or } x = 3$$

Hence $x = 0$ and $x = 3$ are critical numbers of f .

To identify intervals of monotonicity and extreme values you use the following sign chart.

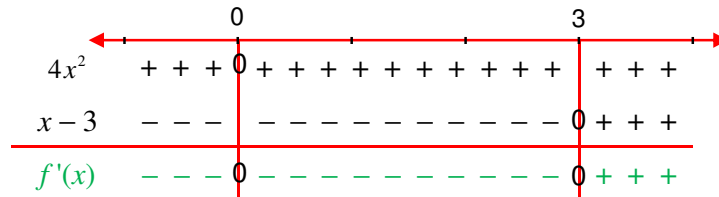

It can be seen from the chart that:

- i** $f'(x) \leq 0$ for all x in the interval $(-\infty, 3)$; thus f is strictly decreasing on $(-\infty, 3]$.
- ii** $f'(x) > 0$ for all x in the interval $(3, \infty)$; thus f is strictly increasing on $[3, \infty)$.
- iii** The sign of f' changes only at a critical number $x = 3$, where it changes sign from negative to positive and hence by the first derivative test, $f(3) = -27$ is the relative minimum value of f .

- e** Intervals of concavity and inflection points.

To identify intervals of concavity and inflection points, you make use of the second derivative;

$$f'(x) = 4x^3 - 12x^2, \quad f''(x) = 12x^2 - 24x, \quad f''(x) = 0 \Rightarrow 12x(x - 2) = 0$$

$$\Rightarrow 12x = 0 \text{ or } x - 2 = 0 \Rightarrow x = 0 \text{ or } x = 2$$

To identify intervals of concavity and inflection points you use the following sign chart.

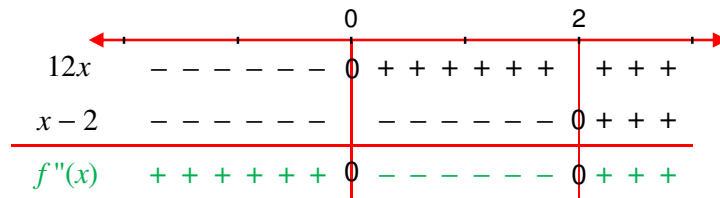

As can be seen from the sign chart

- i** $f''(x) > 0$ for all x in the intervals $(-\infty, 0)$ and $(2, \infty)$; thus by the second derivative test, the graph of f is concave upward on $(-\infty, 0)$ and $(2, \infty)$
- ii** $f''(x) < 0$ on $(0, 2)$ and hence by the second derivative test the graph of f is concave downward on $(0, 2)$.
- iii** The points at which concavity changes are called inflection points.

Therefore, $(0, f(0)) = (0, 0)$ and $(2, f(2)) = (2, -16)$ are the inflection points of the graph of f .

Now using the above information, you can sketch the graph of f as follows:

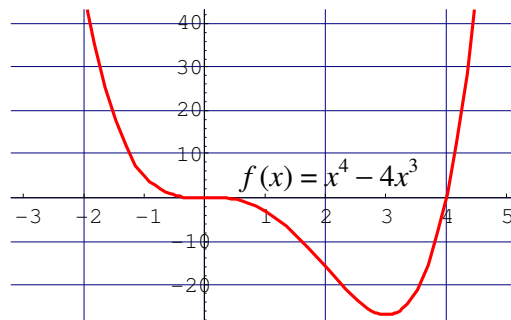

Figure 4.12

Example 15 Sketch the graph of $f(x) = \frac{x}{x^2 + 1}$.

Solution

a $f(x) = \frac{x}{x^2 + 1}$ is defined for all real numbers.

b y-intercept: it is the value of f at $x = 0$

Thus y-intercept = $f(0) = 0$

Hence the graph crosses the y-axis at $(0, 0)$

- c** x -intercept: it is the zero of the function $f(x)$.

$$\text{Which means } \frac{x}{x^2+1} = 0 \Rightarrow x = 0.$$

Therefore; $x = 0$ is the x -intercept.

That means the graph of f crosses the x -axis only at $(0, 0)$.

- d** Intervals of monotonicity and relative extreme values

To identify intervals in which f is monotonic you need to find the derivative of f and find critical numbers.

$$f(x) = \frac{x}{x^2+1} \Rightarrow f'(x) = \frac{1-x^2}{(x^2+1)^2}$$

$$f'(x) = 0 \Rightarrow \frac{1-x^2}{(x^2+1)^2} = 0 \Rightarrow \frac{(1-x)(1+x)}{(x^2+1)^2} = 0$$

$$\Rightarrow x = 1 \text{ or } x = -1.$$

Hence $x = 1$ and $x = -1$ are critical numbers of f .

To identify intervals of monotonicity and extreme values you use the following sign chart.

	-1	1												
$1-x$	+	+	+	+	+	+	+	+	0	-	-	-	-	
$x+1$	-	-	-	-	0	+	+	+	+	+	+	+	+	
$(x^2+1)^2$	+	+	+	+	+	+	+	+	+	+	+	+		
$f'(x)$	-	-	-	-	0	+	+	+	+	0	-	-	-	-

It can be seen from the chart that:

- i** $f'(x) < 0$ for all x in the intervals $(-\infty, -1)$ and $(1, \infty)$; thus f is strictly decreasing on $(-\infty, -1]$ and $[1, \infty)$.
- ii** $f'(x) > 0$ for all x in the interval $(-1, 1)$; thus f is strictly increasing on $[-1, 1]$.
- iii** The sign of f' changes at $x = -1$ and $x = 1$. It changes sign from negative to positive at $x = -1$ and hence by the first derivative test, $f(-1) = \frac{-1}{2}$ is the relative minimum value of f . It also changes sign from positive to negative at $x = 1$ and hence by the first derivative test, $f(1) = \frac{1}{2}$ is a relative maximum value of f .

e Intervals of concavity and inflection points.

To identify intervals of concavity and inflection points, you make use of the second derivative;

$$f'(x) = \frac{1-x^2}{(x^2+1)^2}, \quad f''(x) = \frac{2x(x^2-3)}{(x^2+1)^3}, \quad f''(x) = 0 \Rightarrow \frac{2x(x^2-3)}{(x^2+1)^3} = 0$$

$$\Rightarrow x = 0 \text{ or } x = \sqrt{3} \quad \text{or } x = -\sqrt{3} .$$

To identify intervals of concavity and inflection points you use the following sign chart.

\leftarrow	$-\sqrt{3}$	0	$\sqrt{3}$	\rightarrow												
$2x$	-	-	-	-	-	0	+	+	+	+	+	+	+			
$x-\sqrt{3}$	-	-	-	-	-	-	-	-	-	0	+	+	+			
$x+\sqrt{3}$	-	-	-	0	+	+	+	+	+	+	+	+	+			
$(x^2+1)^3$	+	+	+	+	+	+	+	+	+	+	+	+	+			
$f''(x)$	-	-	-	0	+	+	+	+	0	-	-	-	0	+	+	+

As it can be seen from the sign chart

- i** $f''(x) < 0$ for all x in the intervals $(-\infty, -\sqrt{3})$ and $(0, \sqrt{3})$; thus by the second derivative test the graph of f is concave downward on $(-\infty, -\sqrt{3})$ and $(0, \sqrt{3})$
- ii** $f''(x) > 0$ on $(-\sqrt{3}, 0)$ and $(\sqrt{3}, \infty)$ and hence by the second derivative test, the graph of f is concave upward on $(-\sqrt{3}, 0)$ and $(\sqrt{3}, \infty)$.
- iii** Inflection points of the graph of f are: $(0, 0)$, $(-\sqrt{3}, \frac{-\sqrt{3}}{4})$ and $(\sqrt{3}, \frac{\sqrt{3}}{4})$.

Now using the above information, you can sketch the graph of f as follows:

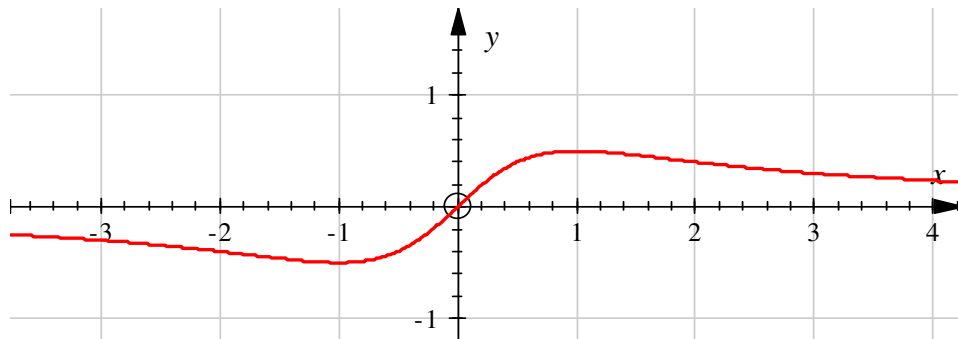

Figure 4.13

Exercise 4.5

Sketch the graph of each of the following functions by indicating the following:

- | | |
|---|---|
| <p>a domain of the function</p> <p>c asymptotes (if any)</p> <p>e local extreme values</p> <p>g inflection points</p> | <p>b intercepts (y-intercept and x-intercept)</p> <p>d intervals of monotonicity</p> <p>f intervals of concavity</p> |
|---|---|

1 $f(x) = x^3 - 12x$

2 $f(x) = e^x$

3 $f(x) = \ln x$

4 $f(x) = \frac{4}{1+x^2}$

5 $f(x) = \frac{1}{4}x^4 - 2x^2$

6 $f(x) = \frac{2x-6}{x^2-9}$

7 $f(x) = x^3 - \frac{3}{2}x^2 + 6x$

8 $f(x) = \frac{1}{2^x-1}$

4.2 MINIMIZATION AND MAXIMIZATION PROBLEMS

The methods you have learned in this unit for finding extreme values have practical applications in many areas of life. A businessperson wants to minimize costs and maximize profits. A traveller wants to minimize transportation time. You know principles in optics which states that light follows the path that takes the least time. In this section you will solve problems such as maximizing areas, volumes and profits and minimizing distances, time, and costs. Let us see the following examples:

Example 1 Find two nonnegative real numbers whose sum is 18 and whose product is maximum.

Solution There are many pairs of numbers whose sum is 18. For instance, (1, 17), (2, 16), (3, 15), (4, 14), (5, 13), (6, 12), (7, 11), (8, 10), (9, 9), (5.2, 12.8), (6.5, 11.5), . . . , etc.

All these pairs have different products, and you cannot list all such pairs and find all the products. As a result you fail to get the maximum product in doing this. Instead of listing such pairs and products you take two variables say x and y such that $x \geq 0$, $y \geq 0$, and $x + y = 18$ with the product xy maximum.

Since $x + y = 18$, then $y = 18 - x$. ($0 \leq x \leq 18$, $0 \leq y \leq 18$)

Thus you want to maximize $x(18 - x) = 18x - x^2$.

Consider $f(x) = 18x - x^2$, which is continuous on $[0, 18]$ and differentiable on $(0, 18)$.

$$f'(x) = 18 - 2x$$

$$f'(x) = 0 \Rightarrow x = 9$$

The maximum occurs either at end points or at critical numbers. Thus evaluating the values of the function at critical numbers and end points, you get,

$$f(0) = 0, f(18) = 0 \text{ and } f(9) = 81$$

Comparing these values, $x = 9$ gives the maximum product. Hence $x = 9$ and $y = 9$ are the two real numbers whose sum is 18 and whose product is maximum.

Example 2 A farmer has 240 m of fencing material and wants to fence a rectangular field that borders a straight river. (No fence is needed along the river).
What are the dimensions of the field that has the largest area?

Solution You need to fence along the three sides of a rectangular field.

For example, you may have $240 = 100 + 100 + 40 = 80 + 80 + 80 = 90 + 90 + 60$ as possibilities for the three sides.

You can list a lot of possibilities; but the problem is which possibility gives the maximum area.

Thus instead of listing the possibilities, you consider the general case: you wish to maximize the area A of the rectangular region. Let x and y be the width and depth of the rectangle.

Then express A in terms of x and y as:

$$A = xy$$

We want to express A as a function of just one variable, so eliminate x by expressing it in terms of y . To do this, you use the given information that the total length of the fencing is 240 m.

$$2y + x = 240$$

$$\Rightarrow x = 240 - 2y$$

$$A(y) = (240 - 2y)y = 240y - 2y^2; \quad 0 \leq y \leq 120$$

$$A(y) = 240y - 2y^2 \text{ is continuous on } [0, 120] \text{ and differentiable on } (0, 120)$$

$$A'(y) = 240 - 4y$$

$$A'(y) = 0 \Rightarrow 240 - 4y = 0 \Rightarrow y = 60$$

Hence $y = 60$ is a critical number.

To get the maximum area, you calculate the value of A at $y = 60$ (the critical number),

$$y = 0 \text{ and } y = 120 \text{ (the two end points): } A(0) = 0 = A(120) \text{ and } A(60) = 7200$$

Therefore $A(60) = 7200$ is the largest value.

Hence $y = 60$ m and $x = 120$ m are the dimensions of the field that give the maximum area.

Example 3 A cylindrical can is to be made to hold 10 litres of oil. Find the dimensions that will minimize the cost of the metal to manufacture the can.

Solution

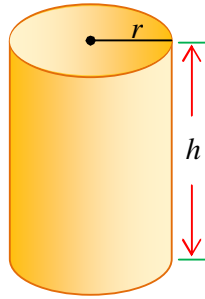

Figure 4.14

In order to minimize the cost of the metal, you have to minimize the total surface area of the cylinder. You see that the sides are made from a rectangular sheet with dimensions $2\pi r$ (circumference of the base circle) and h . So the total surface area is given by

$$A = 2\pi r^2 + 2\pi rh$$

To eliminate h you use the fact that the volume is given as:

$$V = 10 \text{ litres} = 10,000 \text{ cm}^3.$$

$$\Rightarrow \pi r^2 h = 10000 \quad \Rightarrow h = \frac{10000}{\pi r^2}$$

$$\Rightarrow A(r) = 2\pi r^2 + 2\pi r \left(\frac{10000}{\pi r^2} \right) = 2\pi r^2 + \frac{20,000}{r} \Rightarrow A'(r) = 4\pi r - \frac{20,000}{r^2}$$

$$A'(r) = 0 \Rightarrow 4\pi r - \frac{20,000}{r^2} = 0 \Rightarrow r = 10 \left(\sqrt[3]{\frac{5}{\pi}} \right)$$

Applying the second derivative test $A''(r) = 4\pi + \frac{40,000}{r^3} > 0$ for any $r > 0$, and

hence $r = 10 \left(\sqrt[3]{\frac{5}{\pi}} \right)$ gives the minimum value.

Thus the value of h corresponding to $r = 10 \left(\sqrt[3]{\frac{5}{\pi}} \right)$ is $20 \left(\sqrt[3]{\frac{5}{\pi}} \right)$

Thus, to minimize the cost of the can, the radius should be $10 \left(\sqrt[3]{\frac{5}{\pi}} \right)$ cm and the

height should be $r = 20 \left(\sqrt[3]{\frac{5}{\pi}} \right)$ cm.

Example 4 A home gardener estimates that if she plants 16 apple trees, the average yield will be 80 apples per tree. But because of the size of the garden, for each additional tree planted the yield will decrease by 4 apples per tree. How many trees should be planted to maximize the total yield of apples? What is the maximum yield?

Solution To solve this problem consider the following:

- a** If only 16 apple trees are planted, then what is the total average yield?
- b** If 17 apple trees (one additional tree) are planted, then what is the total average yield?
- c** If 18 apple trees (two additional trees) are planted then what is the total average yield?
- d** In general, if $16 + x$ apple trees (x additional trees) are planted, then what is the total average yield?

Now to come to the solution you consider the general case (d) and assume that x additional apple trees, are planted. Thus the total yield will be $(16 + x)(80 - 4x)$, since for each additional apple tree planted, the yield will decrease by 4 apples per tree. Thus, you are going to maximize the function:

$$f(x) = (16 + x)(80 - 4x) = 1280 + 16x - 4x^2 \text{ on } [0, \infty).$$

$$f'(x) = 16 - 8x \quad f'(x) = 0 \Rightarrow 16 - 8x = 0 \quad \Rightarrow x = 2$$

Thus $x = 2$ is the only critical number.

$f''(x) = -8 < 0$ and hence by the second derivative test, the function has a maximum value at critical number 2.

Therefore, 18 trees should be planted to get the maximum yield:

$$f(2) = 18 \times 72 = 1296 \text{ is the maximum yield.}$$

Example 5 A manufacturer wants to design an open box that has a square base and a surface area of 48 sq units as shown in the figure below. What dimensions will produce a box with a maximum volume?

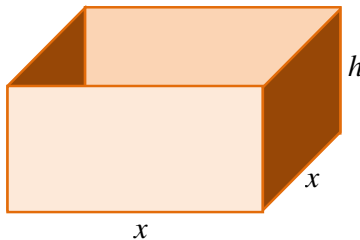

Figure 4.14

Solution Because the base of the box is square, the volume V of the box is given by:

$$V = x^2h$$

The surface area S of the open box is given by:

$$S = (\text{area of base}) + (\text{area of four faces})$$

$$S = x^2 + 4xh$$

Because V is to be optimized, it helps to express V as a function of just one variable.

$$\text{i.e., } h = \frac{S - x^2}{4x} = \frac{48 - x^2}{4x} \quad (\text{since } S = 48 \text{ sq.units})$$

$$\text{Thus, } V(x) = x^2 \left(\frac{48 - x^2}{4x} \right) = 12x - \frac{1}{4}x^3$$

$$V'(x) = 12 - \frac{3}{4}x^2$$

$$V'(x) = 0 \Rightarrow x^2 = 16 \Rightarrow x = \pm 4$$

Since x is the dimension of the box, it is non-negative and hence $x = 4$ is the only critical number.

$$V''(x) = -\frac{3}{2}x < 0 \quad \forall x > 0 \text{ So, } V(4) \text{ is a maximum by the second derivative test.}$$

Therefore, $x = 4$ and $h = 2$ gives the maximum volume, and which is

$$V = (4^2)(2) = 32 \text{ cubic units}$$

Example 6 Find the points on the graph of $f(x) = 1 - x^2$ that are closest to $O(0, 0)$

Solution Look at the graph of $f(x) = 1 - x^2$

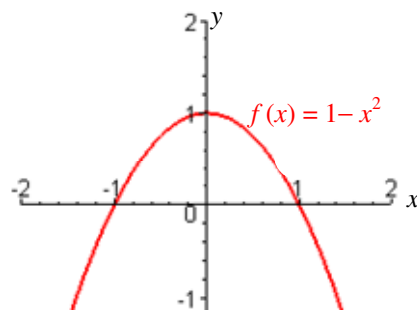

Figure 4.15

Any point on the graph is of the form $(x, 1 - x^2)$

$$\text{Hence } d = \sqrt{(x-0)^2 + (1-x^2-0)^2} = \sqrt{x^2 + (1-x^2)^2}$$

d is a minimum whenever the number under the radical is a minimum.

Thus, you minimize $g(x) = x^2 + (1 - x^2)^2$

$$g(x) = x^2 + 1 - 2x^2 + x^4 = 1 - x^2 + x^4$$

$$g'(x) = -2x + 4x^3$$

$$g'(x) = 0 \Rightarrow 2x(2x^2 - 1) = 0 \Rightarrow x = 0 \text{ or } x = \pm \frac{\sqrt{2}}{2}$$

Therefore, 0 , $-\frac{\sqrt{2}}{2}$ and $\frac{\sqrt{2}}{2}$ are critical numbers.

To check whether these numbers give a minimum distance, you use the second derivative test.

$$g''(x) = -2 + 12x^2 > 0 \text{ for } x = \frac{\sqrt{2}}{2} \text{ and } x = -\frac{\sqrt{2}}{2}$$

$$g\left(\frac{\sqrt{2}}{2}\right) = 1 - \frac{1}{2} + \frac{1}{4} = \frac{3}{4} = g\left(-\frac{\sqrt{2}}{2}\right)$$

Thus, $\left(\frac{\sqrt{2}}{2}, \frac{1}{2}\right)$ and $\left(-\frac{\sqrt{2}}{2}, \frac{1}{2}\right)$ are the closest points to $(0, 0)$.

But the critical number $x = 0$ does not minimize the distance. Why?

Example 7 Suppose the total cost $C(x)$ (in thousands of Birr) for manufacturing x desktop computers per month is given by the function

$$C(x) = 575 + 25x - \frac{1}{4}x^2, 0 \leq x \leq 50$$

- a** Find the marginal cost at a production level of x computers per month.
- b** Use the marginal cost function to approximate the cost of producing the 31st computer.
- c** Use the total cost function to find the exact cost of producing the 31st computer.

Solution

- a** Since marginal cost is the derivative of the cost function $C(x)$, you have

$$C'(x) = 25 - \frac{1}{2}x$$

- b** The marginal cost at a production level of 30 computers is

$$C'(30) = 25 - \frac{1}{2} \times 30 = 10$$

or Birr 10,000 per computer.

That means at a production level of 30 computers per month, the total cost is increasing at the rate of Birr 10,000 per computer.

Hence the cost of producing the 31st computer is approximately Birr 10,000.

- c** The exact cost of producing the 31st computer is

$$\left(\begin{array}{l} \text{Total cost of} \\ \text{producing 31} \\ \text{computers} \end{array} \right) - \left(\begin{array}{l} \text{Total cost of} \\ \text{producing 30} \\ \text{computers} \end{array} \right) = C(31) - C(30)$$

$$= 1,109.75 - 1,100 = 9.75 \text{ or Birr } 9750$$

As a summary from what you have seen in solving problems by the application of differential calculus, the greatest challenge is often to convert the real-life word problem into a mathematical maximization or minimization problem, by setting up the function that is to be maximized or minimized. The following guideline adapted to particular situation may help.

1 Understand the problem

The first step is to read the problem carefully until it is clearly understood. Ask yourself:

What is the unknown? What are the given quantities? What are the given conditions?

2 Draw a diagram (if necessary)

In most problems, it is useful to draw a diagram and identify the given and required quantities on the diagram.

3 Introduce notation

Assign a symbol to the quantity that is to be maximized or minimized and select symbols for the unknowns.

4 Express the quantity which is going to be optimized in terms of the unknowns.

5 If the quantity which is going to be optimized is expressed as a function of more than one unknown in step 4,

use the given information to find relationships (in the form of equations) between these unknowns. Then use these equations to eliminate all but one of the unknown in the expression. Thus the quantity which is going to be optimized will be expressed as a function of one unknown; write the domain of this function and use the methods of solving maximization and minimization problems to get the quantity optimized.

Exercise 4.6

- 1** The product of two positive numbers is 288. Find the numbers which minimize the sum of the second number and twice the first number.

- 2** Find the points on the graph of the function that are closest to the given point.

a $f(x) = x^2 - 4$; $(0, 2)$ **b** $f(x) = x^2 + 1$; $(0, 4)$

c $f(x) = x^2$; $(2, 1)$

- 3** What positive number x minimizes the sum of x and its reciprocal?
- 4** Find the length and width of a rectangle with perimeter 100 m that maximize the area.
- 5** A farmer has a 200 m fencing material to enclose two adjacent sides of a rectangular field. What dimensions should be used so that the enclosed area will be a maximum?
- 6** A dairy farmer plans to enclose a rectangular pasture adjacent to a river. To provide enough grass for the herd, the pasture must have an area of 180,000 m². No fencing is required along the river. What dimensions will use the smallest amount of fencing?
- 7** Find the length and width of a rectangle with area 64 m² that give minimum perimeter.
- 8** The combined perimeter of a circle and a square is 16. Find the dimensions of the circle and square that produce a minimum total area.
- 9** A ten meter wire is to be used to form a square and a circle.
- Express the sum of the areas of the square and the circle as a function $A(x)$ of the side of the square x .
 - Identify the domain of $A(x)$
 - How much wire should be used for the square and how much wire for the circle in order to enclose the smallest total area?
- 10** A company has determined that its total revenue (in Birr) for a product can be modeled by $R(x) = -x^3 + 450x^2 + 52,500x$ where x is the number of units produced (and sold). What production level will yield a maximum revenue?
- 11** Find the number of units that must be produced to minimize the cost function $C(x) = 0.008x^2 + 2x + 304$. What is the minimum cost?
- 12** A mass connected to a spring moves along the x -axis so that its x -coordinate at time t is given by
- $$x(t) = \sin 2t + \sqrt{3} \cos 2t.$$
- What is the maximum distance of the mass from the origin?
- 13** The body temperature (in degree centigrade) of a patient t hours after taking a fever reducing drug is given by
- $$C(t) = 37 + \frac{4}{\sqrt{t+1}}$$
- Find $C(3)$ and $C'(3)$. Give a brief verbal interpretation of these results.

4.3 RATE OF CHANGE

In the previous sections you have seen derivatives as rates of change i.e. $f'(x)$ is the rate of change of the function f with respect to x at the point $(x, f(x))$. In this section, you will see that there are many real-life applications of rates of change. A few are velocity, acceleration, population growth rates, unemployment rates, production rates, and water flow rates. Although rates of change often involve change with respect to time, you can investigate the rate of change of one variable with respect to any other related variable.

When determining the rate of change of one variable with respect to another, you must be careful to distinguish between average and instantaneous rates of change. The distinction between these two rates of change is comparable to the distinction between the slope of the secant line through two points on a graph and the slope of the tangent line at one point on the graph.

The slope of the tangent line is the derivative of a function at the given point; this is regarded as the instantaneous rate of change:

$$f'(c) = \lim_{x \rightarrow c} \frac{f(x) - f(c)}{x - c} \text{ instantaneous rate of change}$$

But the slope of a secant line is determined by two points given on the line; this is regarded as the average rate of change:

$$\frac{f(b) - f(a)}{b - a} = \text{average rate of change}$$

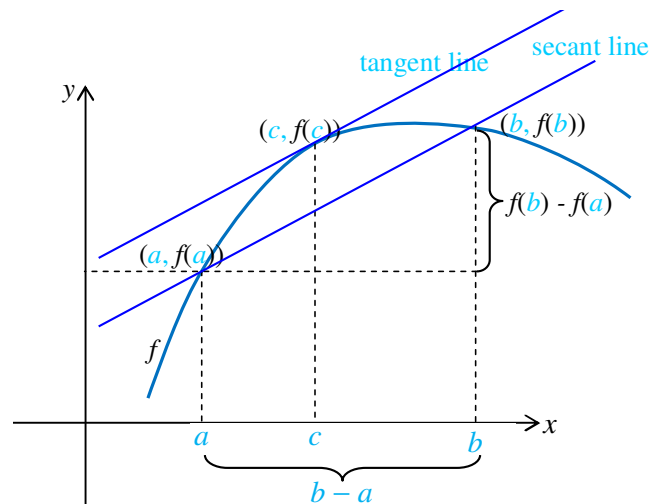

Figure 4.16

Example 1 The concentration C (in milligrams per millilitre) of a drug in a patient's blood stream is monitored at 10-minute intervals for 2 hrs, where t is measured in minutes, as shown in the table. Find the average rate of change over each interval.

a [0, 10] **b** [0, 40] **c** [100, 120]

t	0	10	20	30	40	50	60	70	80	90	100	110	120
c	0	2	17	37	55	73	89	103	111	113	113	103	68

Solution

a For the interval [0, 10], the average rate of change is

$$\frac{\Delta c}{\Delta t} = \frac{2-0}{10-0} = \frac{2}{10} = 0.2 \text{ mg per ml/min.}$$

b For the interval [0, 40], the average rate of change is

$$\frac{\Delta c}{\Delta t} = \frac{55-0}{40-0} = \frac{55}{40} = \frac{11}{8} \text{ mg per ml/min}$$

c For the interval [100, 120], the average rate of change is

$$\frac{\Delta c}{\Delta t} = \frac{68-113}{120-100} = \frac{-45}{20} = -\frac{9}{4} \text{ mg per ml/min}$$

Example 2 If a free-falling object is dropped from a height of 100m, and resistance is neglected, the height h (in metre) of the object at time t (in seconds) is given by $h(t) = -16t^2 + 100$.

i Find the average velocity of the object over

a [1, 2] **b** [1, 1.5] **c** [0, 2]

ii Find the instantaneous rate of change at

a $t = 1$ sec **b** $t = 2$ sec **c** $t = 3$ sec **d** $t = 1.5$ sec

Solution

i a $h(1) = 84, h(2) = 36$

Average velocity over [1, 2] is given by:

$$\frac{h(2) - h(1)}{2 - 1} = \frac{36 - 84}{1} = -48 \text{ m/sec}$$

b $h(1) = 84, h(1.5) = 64$

Average velocity over [1, 1.5] is given by

$$\frac{h(1.5) - h(1)}{1.5 - 1} = \frac{64 - 84}{0.5} = -40 \text{ m/sec}$$

c $h(0) = 100, h(2) = 36$

Average velocity over $[0, 2]$ is given by

$$\frac{h(2) - h(0)}{2 - 0} = \frac{36 - 100}{2} = -32 \text{ m/sec}$$

ii $h(t) = -16t^2 + 100 \Rightarrow h'(t) = -32t.$

Thus, the instantaneous rates of change are given as follows:

a $h'(1) = -32 \text{ m/sec}$

b $h'(2) = -64 \text{ m/sec}$

c $h'(3) = -96 \text{ m/sec}$

d $h'(1.5) = -48 \text{ m/sec}$

Exercise 4.7

- 1** The height h (in meters) of a free-falling object at time t (in seconds) is given by $h(t) = -16t^2 + 180$. Find
- i** the average velocity of the object over these intervals
- a** $[0, 1]$ **b** $[1, 2]$ **c** $[2, 3]$ **d** $[1, 5]$
- ii** the instantaneous velocity of the object at
- a** $t = 0.5 \text{ sec}$ **b** $t = 1 \text{ sec}$ **c** $t = 1.5 \text{ sec}$ **d** $t = 2 \text{ sec}$
- 2** The population of a developing rural area has been growing according to the model $P(t) = 22t^2 + 52t + 10,000$, where t is time in years, with $t = 0$ representing the year 2000 E.C.
- a** Evaluate P for $t = 0, t = 5, t = 8$ and $t = 10$. Explain these values.
- b** Determine the population growth rate, $\frac{dP}{dt}$.
- c** Evaluate $\frac{dP}{dt}$ for the same values as in part **a**. Explain your results.

Related rates

In this section, you will study problems involving variables that are changing with respect to time. If two or more such variables are related to each other, then their rates of change with respect to time are also related.

For instance, suppose that x and y are related by the equation $y = 2x$. If both variables are changing with respect to time then their rates of change will also be related, by the equation

$$\frac{dy}{dt} = 2 \frac{dx}{dt}$$

Examining two rates that are related

Example 3 A stone is dropped into a calm pool of water, causing ripples in the form of concentric circles, as shown in the figure below. The radius r of the outer ripple is increasing at a constant rate of 1 cm per second. When the radius is 4 cm, at what rate is the total area A of the disturbed water changing?

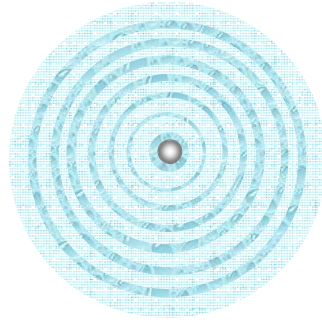

Figure 4.17

Solution The radius r ; and the area A of a circle are related as follows:

$$A = \pi r^2 \Rightarrow \frac{dA}{dt} = 2\pi r \frac{dr}{dt}$$

When $r = 4$ and $\frac{dr}{dt} = 1$, we have $2\pi r \frac{dr}{dt} = 2\pi(4)(1) = 8\pi \text{ cm}^2/\text{sec}$.

Therefore, the area is changing at the rate of $8\pi \text{ cm}^2/\text{sec}$.

Example 4 Air is being pumped into a spherical balloon at the rate of $4.5 \text{ cm}^3/\text{min}$. Find the rate of change of the radius when the radius is 2 cm.

Solution Let r be the radius of the sphere, then the volume V of the sphere is

given by $V = \frac{4}{3}\pi r^3$

$$\begin{aligned} \frac{dV}{dt} = 4\pi r^2 \frac{dr}{dt} &\Rightarrow \frac{dr}{dt} = \frac{1}{4\pi r^2} \frac{dV}{dt} = \frac{1}{4\pi(2)^2} \times 4.5 \quad (\text{since } \frac{dV}{dt} = 4.5) \\ &= \frac{4.5}{16\pi} \text{ cm/min} \approx 0.09 \text{ cm/min} \end{aligned}$$

Example 5 A ladder 5 m long rests against a vertical wall. If the bottom of the ladder slides away from the wall at a rate of $\frac{1}{4} \text{ m/sec}$, how fast is the top of the ladder sliding down the wall when the bottom of the ladder is 3 m from the wall?

Solution

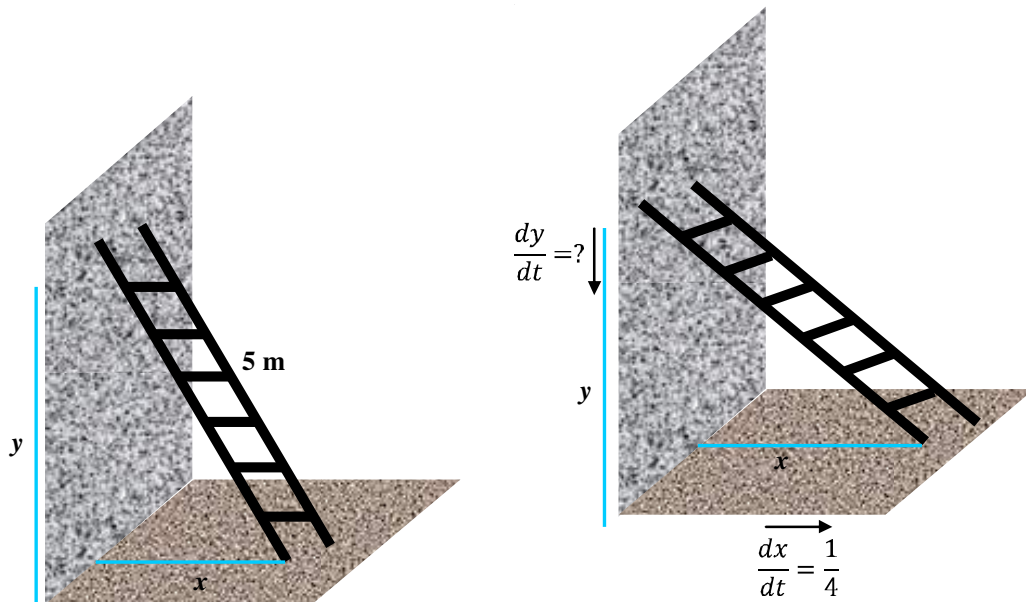

Figure 4.18

$$3^2 + y^2 = 25 \Rightarrow y^2 = 16$$

$$\Rightarrow y = 4$$

$$x^2 + y^2 = 25 \Rightarrow 2x \frac{dx}{dt} + 2y \frac{dy}{dt} = 0$$

$$\Rightarrow \frac{dy}{dt} = \frac{-x}{y} \frac{dx}{dt} = \frac{-3}{4} \left(\frac{1}{4} \right) = \frac{-3}{16} \text{ m/sec.}$$

The fact that $\frac{dy}{dt}$ is negative means that the distance from the top of the ladder to

the ground is decreasing at a rate of $\frac{3}{16}$ m/sec. In other words, the top of the ladder

is sliding down the wall at a rate of $\frac{3}{16}$ m/sec.

Example 6 A water tank is in the shape of an inverted circular cone with base radius 3 m and height 5 m. If water is being pumped into the tank at a rate of $2 \text{ m}^3/\text{min}$, find the rate at which the water level is rising when the water is 3 m deep.

Solution

$$\frac{r}{h} = \frac{3}{5} \Rightarrow h = \frac{5}{3}r \Rightarrow r = \frac{3}{5}h$$

$$V = \frac{1}{3}\pi r^2 h = \frac{1}{3}\pi \left(\frac{3}{5}h\right)^2 h = \frac{3}{25}\pi h^3$$

$$\frac{dV}{dt} = \frac{9}{25}\pi h^2 \frac{dh}{dt} = \frac{1}{3}\pi r^2 \left(\frac{5}{3}r\right)$$

$$\Rightarrow \frac{dh}{dt} = \frac{25}{9\pi h^2} \frac{dv}{dt} = \frac{25}{9\pi(3)^2} \times 2\text{m/min} = \frac{50}{81\pi} \text{ m/min}$$

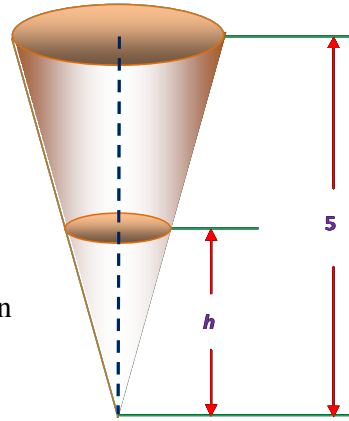

Figure 4.19

Example 7 Given $x^2y + xy = 6$,

- a** Find the rate of change of x with respect to y .
- b** Find the rate of change of y with respect to x .

Solution

a In this case we assume x is differentiable with respect to y

$$\text{Thus } \frac{d}{dy}(x^2y + xy) = \frac{d}{dy}(6)$$

$$\Rightarrow x^2 + x + 2xy \frac{dx}{dy} + y \frac{dx}{dy} = 0$$

$$\Rightarrow (2xy + y) \frac{dx}{dy} = -x^2 - x$$

$$\Rightarrow \frac{dx}{dy} = \frac{-x^2 - x}{2xy + y}$$

b

$$\frac{d}{dx}(x^2y + xy) = \frac{d}{dx}(6)$$

$$\Rightarrow y(2x) + x^2 \frac{dy}{dx} + y + x \frac{dy}{dx} = 0$$

$$\Rightarrow (x^2 + x) \frac{dy}{dx} = -2xy - y$$

$$\Rightarrow \frac{dy}{dx} = \frac{-2xy - y}{x^2 + x} = \frac{1}{\frac{-2xy - y}{x^2 + y}} = \frac{1}{\frac{dy}{dx}}$$

Example 8 The total sales S (in thousands of copies of movies) for a home video movie t months after the movie is introduced are given by:

$$S(t) = \frac{125t^2}{t^2 + 100}$$

- 4** Find $\frac{dy}{dx}$ and $\frac{dx}{dy}$ assuming that y is differentiable with respect to x and x is also differentiable with respect to y .
- a** $x^2 + y^2 = 25$ **b** $3xy + y^2x - x^2y = 10$
c $x + xy^2 - y = xy$ **d** $xy + x^2y^2 = x^3y^3$
e $x \sin y + y \cos x = xy$
- 5** A spherical balloon is inflated with gas at the rate of 20 cm^3 min. How fast is the radius of the balloon changing at the instant when the radius is
a 1 cm? **b** 2 cm? **c** 3 cm?
- 6** The radius r of a right circular cone is increasing at a rate of 2 cm/min . The height h of the cone is related to the radius by $h = 3r$. Find the rate of change of the volume when
a $r = 3 \text{ cm}$ **b** $r = 6 \text{ cm}$



Key Terms

absolute maximum	decreasing function	monotonicity
absolute minimum	extreme values	relative maximum
concave downward	first derivative test	relative minimum
concave upward	increasing function	Rolle's theorem
concavity	inflection point	second derivative test
critical number	mean-value theorem	



Summary

After studying this unit, you should know the definition of the following technical terms and have acquired the skills to find them or test them.

1 **Critical number**

Suppose f is defined at c and either $f'(c) = 0$ or $f'(c)$ does not exist. Then the number c is called a **critical number** of f and the point with coordinates $(c, f(c))$ on the graph of f is called a **critical point**; this critical point is either a **valley** or a **peak** of the graph.

2 **Absolute maximum and absolute minimum**

Let f be a function defined on some set S that contains c . Then

$f(c)$ is an **absolute maximum** of f on S if $f(c) \geq f(x)$ for all x in S .

$f(c)$ is an **absolute minimum** of f on S if $f(c) \leq f(x)$ for all x in S .

3 Relative maximum and relative minimum

The function f is said to have a **relative maximum** at c , if $f(c) \geq f(x)$ for all x in an open interval containing c .

The function f is said to have a **relative minimum** at c , if $f(c) \leq f(x)$ for all x in an open interval containing c .

4 First derivative test

Let f be a function which is continuous and differentiable on an interval I . Then

a First derivative test for local extreme values

If f' changes sign from positive to negative at c then f has a **local maximum** value at c for some critical number c .

If f' changes sign from negative to positive at c then f has a **local minimum** value at c for some critical number c .

b First derivative test for intervals of monotonicity

If $f'(x) > 0$ on I , then f is **strictly increasing** on I ; if $f'(x) < 0$ on I , then f is **strictly decreasing** on I .

5 Second derivative test

Let f be a function such that $f'(c) = 0$ and the second derivative exists on an open interval I containing c . Then

a Second derivative test for local extreme values

If $f''(c) > 0$ then $f(c)$ is a local minimum value on I .

If $f''(c) < 0$ then $f(c)$ is a local maximum value on I .

If $f''(c) = 0$, then the test fails.

b Second derivative test for intervals of concavity

If $f''(x) > 0$ for all x in I then the graph of f is **concave upward** on I .

If $f''(x) < 0$ for all x in I then the graph of f is **concave downward** on I .

6 Inflection point

The point at which concavity changes, either from concave up to concave down; or from concave down to concave up is called an **inflection point**.



Review Exercises on Unit 4

- 1 For each of the following functions find: critical numbers, local extreme values, intervals of monotonicity, intervals of concavity and inflection points.

<p>a $f(x) = x^4 - 8x^2 + 6$</p> <p>c $f(x) = \frac{2x}{x^2 + 1}$</p>	<p>b $f(x) = x^3 + 3x^2 - 9x + 5$</p> <p>d $f(x) = \frac{x^2 - 2x + 4}{x - 2}$</p>
---	--
- 2 Find the absolute maximum and minimum values of each of the following functions on the indicated intervals.

<p>a $f(x) = x^4 - 8x^2 + 6$; $[-3, 3]$</p> <p>c $f(x) = \frac{2x}{x^2 + 1}$; $[1, 2]$</p>	<p>b $f(x) = x^3 + 3x^2 - 9x + 5$; $[-2, 2]$</p> <p>d $f(x) = \frac{x^2 - 2x + 4}{x - 2}$; $[-3, 1]$</p>
--	--
- 3 A box is to have a square base, an open top, and volume of 32 m^3 . Find the dimensions of the box that use the least amount of material.
- 4 Determine the point(s) $f(x) = x^2 + 1$ that are closest to the point $(0, 2)$.
- 5 Find the maximum and minimum of the function $f(x) = \cos 2x - 2 \sin x$ for $0 \leq x \leq 2\pi$.
- 6 A window whose bottom is a rectangle and top is a semicircle being built. If there is 12m of framing materials, then what must be the dimension of the window?
- 7 Determine the area of the largest rectangle that can be inscribed in a circle of radius 9 m.
- 8 Water is being poured into a conical vase at a rate of $18 \text{ cm}^3/\text{sec}$. The diameter of the cone is 30 cm and its height is 25 cm. At what rate is the water level rising when its depth is 20 cm?
- 9 Two poles, one 6 m tall and the other 15 m tall, are 20 m apart. A wire is attached to the top of each pole and is also staked to the ground somewhere between the two poles. Where should the wire be staked so that the minimum amount of wire is used?
- 10 A car travelling north at 48 km/hr is approaching an intersection. A truck, travelling East at 60 km/hr is moving away from the same intersection. How is the distance between the car and the truck changing when the car is 9 m from the intersection and the truck is 40 m from the intersection?

Unit 5

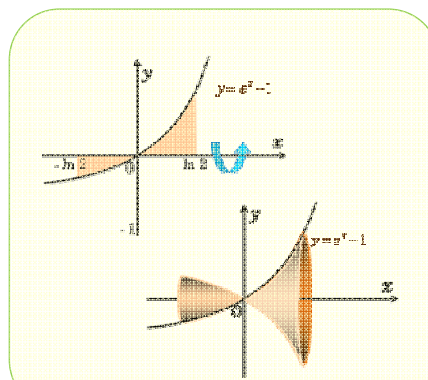

INTRODUCTION TO INTEGRAL CALCULUS

Unit Outcomes:

After completing this unit, you should be able to:

- *understand the concept of definite integral.*
- *integrate polynomial functions, simple trigonometric functions, exponential and logarithmic functions.*
- *use the various techniques of integration to evaluate a given integral.*
- *use the fundamental theorem of calculus for computing definite integrals.*
- *apply the knowledge of integral calculus to solve real life mathematical problems.*

Main Contents

5.1 INTEGRATION AS REVERSE PROCESS OF DIFFERENTIATION

5.2 TECHNIQUES OF INTEGRATION

5.3 DEFINITE INTEGRALS, AREA AND FUNDAMENTAL THEOREM OF CALCULUS

5.4 APPLICATIONS OF INTEGRAL CALCULUS

Key terms

Summary

Review Exercises

INTRODUCTION

You have just seen **differential calculus**, which is one of the two branches of calculus. In this unit you shall see the other branch of calculus, called **integral calculus**. Integration is the reverse process of differentiation. It is the process of finding the function itself when its derivative is known.

For example, if the slope of a tangent at an arbitrary point of a curve is known, then it is possible to determine the equation of the curve using the method of integral calculus. Also, it is possible to find distance of a moving object in terms of time, if its velocity or acceleration is known.

Differential calculus deals with rate of change of functions, whereas integral calculus deals with total size or value such as areas enclosed by curves, volumes of revolution, lengths of a curves, total mass, total force, etc.

Differential calculus and integral calculus are connected by a theorem called the **fundamental theorem of calculus**.

In integral calculus there are two kinds of integrations which are called the **indefinite integral** or the anti derivative and the **definite integral**.

The indefinite integral or the anti derivative involves finding the function whose derivative is known.

The definite integral, denoted by $\int_a^b f(x) dx$ is informally defined to be the signed area of the region in the xy -plane bounded by the curve $y = f(x)$, the x -axis and the vertical lines $x = a$ and $x = b$.

One of the main goals of this unit is to examine the theory of integral calculus and introduce you to its numerous applications in science and engineering.

5.1 INTEGRATION AS REVERSE PROCESS OF DIFFERENTIATION

5.1.1 The Concept of Indefinite Integral

ACTIVITY 5.1

- 1 Find at least three different functions which have derivative $2x$. Describe similarities (and differences) between the functions you found.
- 2 Write the set of all functions with derivative $2x$.

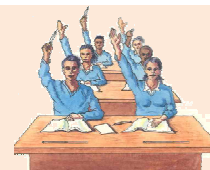

3 Check that all of the functions:

$f(x) = x^2 + 3x + 1$, $g(x) = x^2 + 3x$, $h(x) = x^2 + 3x - 12$ and $k(x) = x^2 + 3x + \pi$ have the same derivative $2x + 3$.

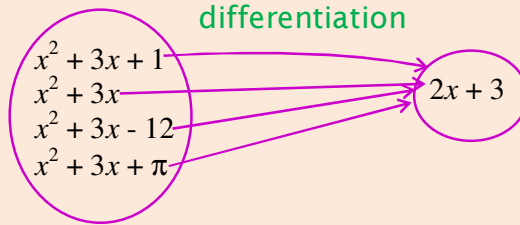

In general, $\frac{d}{dx}(x^2 + 3x + c) = 2x + 3$ for any constant c .

Draw the graphs of f , g , h and k together, using same pair of axes of reference.

Definition 5.1

The process of finding $f(x)$ from its derivative $f'(x)$ is said to be anti differentiation or integration. $f(x)$ is said to be the **anti derivative** of $f'(x)$.

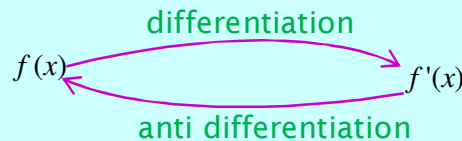

Integration is the reverse operation of differentiation.

Definition 5.2

The set of all anti derivatives of a function $f(x)$ is called the **indefinite integral** of $f(x)$. The indefinite integral of $f(x)$ is denoted by $\int f(x)dx$ read as “the integral of $f(x)$ with respect to x ”.

- ✓ The symbol \int is said to be the **integral sign**.
- ✓ The function $f(x)$ is said to be the **integrand** of the integral.
- ✓ dx denotes that the variable of integration is x .
- ✓ If a function has an integral, then it is said to be integrable.
- ✓ If $F'(x) = f(x)$, then $\int f(x)dx = F(x) + c$
- ✓ $\int f(x)dx$ is read as, “the **integral of $f(x)$** with respect to x ”.
- ✓ c is said to be the constant of integration.

Example 1 $\int x dx = \frac{x^2}{2} + c$ Because $\frac{d}{dx}\left(\frac{x^2}{2} + c\right) = \frac{2x}{2} + 0 = x$

Note:

i $\int f'(x)dx = f(x) + c$

ii $\int \frac{d}{dx} f(x)dx = f(x) + c$

iii $\frac{d}{dx} \int f(x)dx = f(x)$

Example 2 $\int \frac{d}{dx}(4x+5)dx = \int 4dx = 4x + c$ Because $\frac{d}{dx}(4x+c) = 4$

Example 3 You know that $\frac{d}{dx}(x^6) = 6x^5 \Rightarrow \frac{1}{6} \frac{d}{dx}(x^6) = x^5$

$$\begin{aligned} \Rightarrow \int x^5 dx &= \int \frac{1}{6} \frac{d}{dx}(x^6) dx \\ &= \int \frac{d}{dx} \left(\frac{x^6}{6} \right) dx = \frac{x^6}{6} + c \end{aligned}$$

Again, $\frac{d}{dx} \int x^5 dx = \frac{d}{dx} \left(\frac{x^6}{6} + c \right) = x^5$

Integration of some simple functions

ACTIVITY 5.2



1 Copy and fill in the following table

$f(x)$	4	x	x^2	x^3	x^{10}	x^n	$\sin x$	$\cos x$	$\tan x$	$\cot x$	e^x	4^x	$\ln x$	$\log x$
$f'(x)$														

2 By observing the table in **Problem 1** above, evaluate each of the following integrals.

a $\int x^4 dx$

b $\int \sin x dx$

c $\int \cos x dx$

d $\int \sec^2 x dx$

e $\int \csc^2 x dx$

f $\int e^x dx$

g $\int 4^x dx$

h $\int \frac{1}{x} dx$

i $\int \frac{1}{x \ln 10} dx$

In this section, you will see how to find the integrals of constant, power, exponential and logarithmic functions and simple trigonometric functions.

The integration of a constant function

$\int 0 dx = c$, where c is a constant.

$\int cdx = cx + d$, where c is a given constant and d is the constant of integration.

When $c = 1$, $\int dx = x + d$.

Integrating x^n , integration of a power function

Differentiating x^{n+1} gives $(n+1)x^n$.

So $\int (n+1)x^n dx = x^{n+1} + c$

Thus $\int x^n dx = \frac{x^{n+1}}{n+1} + c$; $n \neq -1$.

Example 4 Integrate each of the following functions with respect to x .

a 4

b x^7

c x^{-5}

d $x^{\frac{1}{2}}$

e $x^{-\frac{3}{5}}$

f $x^{-\frac{4}{3}}\sqrt{x}$

Solution

a $\int 4 dx = 4x + c$

b $\int x^7 dx = \frac{x^{7+1}}{7+1} + c = \frac{x^8}{8} + c$

c $\int x^{-5} dx = \frac{x^{-5+1}}{-5+1} + c = \frac{x^{-4}}{-4} + c = -\frac{1}{4x^4} + c$

d $\int x^{\frac{1}{2}} dx = \frac{x^{\frac{1}{2}+1}}{\frac{1}{2}+1} + c = \frac{x^{\frac{3}{2}}}{\frac{3}{2}} + c = \frac{2}{3}\sqrt{x^3} + c$

e $\int \frac{1}{x^{-\frac{3}{5}}} dx = \frac{x^{-\frac{3}{5}+1}}{-\frac{3}{5}+1} + c = \frac{x^{\frac{2}{5}}}{\frac{2}{5}} + c = \frac{5x^{\frac{2}{5}}}{2} + c$

f $\int x^{-\frac{4}{3}}\sqrt{x} dx = \int x^{-\frac{4}{3}+\frac{1}{2}} dx = \frac{x^{\frac{1}{6}}}{\frac{1}{6}} = 6\sqrt[6]{x}$.

Let k be a constant and $n \neq -1$, then $\int kx^n dx = \frac{k}{n+1}x^{n+1} + c$.

Integrating $(ax + b)^n$ with respect to x

Example 5 Let $y = (3x + 5)^{10}$, then using the substitution

$u = 3x + 5$, we have $y = u^{10}$.

Then, $\frac{dy}{dx} = \frac{dy}{du} \cdot \frac{du}{dx} = 10u^9 \times 3 = 3 \times 10 (3x + 5)^9$

$\int 3 \times 10 (3x + 5)^9 dx = (3x+5)^{10} + c$

In general, by applying the same technique as **Example 5**, you have

$$\frac{d}{dx}(ax+b)^{n+1} = a(n+1)(ax+b)^n \text{ so that}$$

$$\int a(n+1)(ax+b)^n dx = (ax+b)^{n+1} + c.$$

Thus, $\int (ax+b)^n dx = \frac{1}{a(n+1)}(ax+b)^{n+1} + c$. Where $n \neq -1$ and $a \neq 0$.

Note:

$$\int k(ax+b)^n dx = \frac{k}{a(n+1)}(ax+b)^{n+1} + c, n \neq -1 \text{ and } a \neq 0.$$

Example 6 Integrate each of the following functions with respect to x .

a $5x^6$ **b** $\frac{1}{2x^4}$ **c** $(2x-1)^{11}$ **d** $(4x+3)^8$

e $5(2-3x)^{\frac{1}{2}}$ **f** $4\sqrt[3]{1-x^5}$ **g** $(3x+5)^3\sqrt{3x+5}$

Solution

a Using $\int kx^n dx = \frac{k}{n+1}x^{n+1} + c$, you get $\int 5x^6 dx = \frac{5}{7}x^7 + c$

b $\int \frac{1}{2x^4} dx = \int \frac{1}{2}x^{-4} dx = \frac{1}{2} \left(\frac{x^{-3}}{-3} \right) + c = -\frac{1}{6x^3} + c$

c $\int (2x-1)^{11} dx = \frac{1}{2(11+1)}(2x-1)^{11+1} = \frac{(2x-1)^{12}}{24} + c$

d $\int (4x+3)^8 dx = \frac{1}{4 \times 9}(4x+3)^9 + c = \frac{(4x+3)^9}{36} + c$

e $\int 5(2-3x)^{\frac{1}{2}} dx$. Here $k=5, a=-3, n=\frac{1}{2}$

$$\text{Hence, } \int 5(2-3x)^{\frac{1}{2}} dx = \frac{5}{(-3)\left(\frac{1}{2}+1\right)}(2-3x)^{\frac{1}{2}+1} + c$$

$$= -\frac{10}{9}(2-3x)\sqrt{2-3x} + c$$

f $\int 4\sqrt[3]{(1-x)^5} dx = \frac{4}{-1\left(\frac{5}{3}+1\right)}(1-x)^{\frac{5}{3}+1} + c = -\frac{3}{2}(1-x)^2\sqrt[3]{(1-x)^2} + c$

g $\int (3x+5)^3\sqrt{3x+5} dx = \int (3x+5)^{\frac{7}{2}} dx = \frac{(3x+5)^{\frac{9}{2}}}{3 \times \frac{9}{2}} + c = \frac{2(3x+5)^4\sqrt{3x+5}}{27} + c$

Exercise 5.1

Integrate each of the following expressions with respect to x .

- | | | | |
|---------------------------------|-------------------------------|--------------------------------------|----------------------------------|
| 1 x^3 | 2 $2x^4$ | 3 x^{-3} | 4 $x^{\frac{2}{5}}$ |
| 5 $\frac{4}{x^{1.5}}$ | 6 $6x^2\sqrt{x}$ | 7 $\frac{1}{8\sqrt[3]{x}}$ | 8 $(3x-1)^6$ |
| 9 $\sqrt[3]{1-2x}$ | 10 $8\sqrt[4]{4-3x^3}$ | 11 $\frac{3}{\sqrt[4]{4-5x}}$ | 12 $(2x-3)^{\frac{1}{2}}$ |
| 13 $(4x-\pi)^{\sqrt{2}}$ | | | |

Integration of exponential functions

You should remember that $\frac{d}{dx} e^x = e^x$

Hence, $\int e^x dx = e^x + c$. Also, $\frac{d}{dx}(ke^x) = ke^x$, hence $\int ke^x dx = ke^x + c$

Similarly $\frac{d}{dx} e^{kx} = ke^{kx} \Rightarrow \frac{1}{k} \frac{d}{dx} e^{kx} = e^{kx}$. Hence $\int e^{kx} dx = \frac{e^{kx}}{k} + c$

For $a > 0$, $\frac{d}{dx} a^x = a^x \ln a \Rightarrow \frac{1}{\ln a} \frac{d}{dx} a^x = a^x$

Hence $\int a^x \ln a dx = a^x + c$

Thus, $\int a^x dx = \frac{a^x}{\ln a} + c$; $a > 0$ and $a \neq 1$.

Note:

$$\int ka^x dx = \frac{k}{\ln a} a^x + c \quad \text{and} \quad \int a^{kx} dx = \frac{a^{kx}}{k \ln a} + c$$

Example 7 Integrate each of the following expressions with respect to x .

- | | | | |
|----------------------|---------------------|----------------------|-----------------------|
| a $3e^x$ | b e^{2x} | c 2^x | d e^{-x} |
| e $5e^{1-2x}$ | f 3^{4+2x} | g $3e^{4+3x}$ | h $\sqrt{e^x}$ |

Solution

a $\int 3e^x dx = 3e^x + c$

b $\int e^{2x} dx = \frac{e^{2x}}{2} + c$

c $\int 2^x dx = \frac{2^x}{\ln 2} + c$

$$\begin{aligned} \text{d} \quad \int e^{-x} dx &= \int e^{(-1)x} dx = \frac{e^{-x}}{-1} + c = -e^{-x} + c \\ \text{e} \quad \int 5e^{1-2x} dx &= \int 5e \times e^{-2x} dx = 5e \left(\frac{e^{-2x}}{-2} \right) + c = \frac{-5e^{1-2x}}{2} + c \\ \text{f} \quad \int 3^{4+2x} dx &= \int 3^4 \times 3^{2x} dx = \int 81 \times 9^x dx = \frac{81 \times 9^x}{\ln 9} + c \\ \text{g} \quad \int 3e^{4+3x} dx &= \int 3e^4 \times e^{3x} dx = 3e^4 \times \frac{e^{3x}}{3} + c = e^{4+3x} + c \\ \text{h} \quad \int \sqrt{e^x} dx &= \int e^{\frac{1}{2}x} dx = \frac{e^{\frac{1}{2}x}}{\frac{1}{2}} + c = 2e^{\frac{1}{2}x} + c = 2\sqrt{e^x} + c \end{aligned}$$

Exercise 5.2

Find the integral of each of the following expressions with respect to x .

1 e^{3x}	2 e^{-5x}	3 5^{x+1}	4 2^{4-x}	5 e^{2-3x}
6 $4e^{-1-2x}$	7 $\frac{5}{e^{\pi+x}}$	8 $\sqrt{3}^{x+5}$	9 $\frac{4e^4}{e^{4x+1}}$	10 $\sqrt{e^{2x}}$
11 4^{3x-5}	12 $\frac{2^{1-3x}}{3^{x+1}}$	13 $2^{x+3} \times 3^{4-2x}$		

Integration of $\frac{1}{x}$

In $\int x^n dx$, you put a restriction $n \neq -1$. Thus, integrating $\int \frac{1}{x} dx = \int x^{-1} dx$ cannot be done using the rule of $\int x^n dx = \frac{x^{n+1}}{n+1} + c$. You recall that for $x > 0$, $\frac{d}{dx} \ln x = \frac{1}{x}$

$$\Rightarrow \int \frac{1}{x} dx = \ln x + c.$$

What happens if $x < 0$? Let $x < 0$, then $-x > 0$ so that $\ln(-x)$ is defined.

Moreover, $\frac{d}{dx} \ln(-x) = \frac{1}{-x} \frac{d}{dx}(-x) = \frac{-1}{-x} = \frac{1}{x}$ by the chain rule.

\Rightarrow For $x < 0$, $\int \frac{1}{x} dx = \ln(-x) + c$

Thus, $\int \frac{1}{x} dx = \begin{cases} \ln x + c, & \text{if } x > 0 \\ \ln(-x) + c, & \text{if } x < 0 \end{cases} \Rightarrow \int \frac{1}{x} dx = \ln|x| + c$

Note:

If k is a constant, then $\int \frac{k}{x} dx = k \ln|x| + c$.

Example 8 Evaluate

a $\int \frac{3}{x} dx$

b $\int \frac{1}{2x} dx$

Solution

a Using $\int \frac{k}{x} dx = k \ln|x| + c$, you obtain $\int \frac{3}{x} dx = 3 \ln|x| + c$

b $\int \frac{1}{2x} dx$, here $k = \frac{1}{2}$

$$\text{Hence, } \int \frac{1}{2x} dx = \frac{1}{2} \ln|x| + c = \ln \sqrt{|x|} + c.$$

Now consider the derivative of $\ln(ax+b)$ with respect to x , where $a \neq 0$.

$$\begin{aligned} \frac{d}{dx} \ln(ax+b) &= \frac{1}{ax+b} \times \frac{d}{dx} (ax+b) && \text{(by the chain rule)} \\ &= \frac{a}{ax+b} \Rightarrow \frac{1}{a} \frac{d}{dx} \ln(ax+b) = \frac{1}{ax+b} \\ &\Rightarrow \int \frac{1}{a} \frac{d}{dx} (\ln(ax+b)) dx = \int \frac{1}{ax+b} dx \\ &\Rightarrow \int \frac{d}{dx} \frac{1}{a} \ln(ax+b) dx = \int \frac{1}{ax+b} dx \\ &\Rightarrow \int \frac{1}{ax+b} dx = \frac{1}{a} \ln|ax+b| + c \end{aligned}$$

Example 9 Evaluate each of the following integrals.

a $\int \frac{1}{4x+1} dx$

b $\int \frac{5}{2-3x} dx$

Solution

a Using $\int \frac{1}{ax+b} dx = \frac{\ln(ax+b)}{a} + c$, you have

$$\int \frac{1}{4x+1} dx = \frac{\ln(4x+1)}{4} + c$$

b $\int \frac{5}{2-3x} dx = \frac{5 \ln|2-3x|}{-3} + c = -\frac{5}{3} \ln|2-3x| + c.$

Note that, $\int \frac{1}{x} dx = \ln|x| + c = \ln|x| + 1ne^c = \ln|x|e^c = \ln|x|A; A = e^c$

Example 10 Evaluate the integral $\int \frac{1}{3x-1} dx$,

Solution
$$\int \frac{1}{3x-1} dx = \frac{\ln|3x-1|}{3} + c = \frac{1}{3} \ln|3x-1| + \ln e^c = \ln \left| \sqrt[3]{(3x-1)e^c} \right|$$

$$= \ln A \left| \sqrt[3]{3x-1} \right|, A = e^c$$

Exercise 5.3

Integrate each of the following expressions with respect to x .

1 $\frac{1}{3x}$	2 $\frac{5}{2x}$	3 $\frac{2}{x+1}$
4 $\frac{3}{2x-1}$	5 $\frac{\sqrt{2}}{1-3x}$	6 $\frac{4}{\pi x-1}$
7 $\frac{-3}{5-2x}$	8 $\frac{1}{\left(\frac{1}{2}x+1\right)}$	9 $\frac{1}{x(x+1)}$

5.1.2 Properties of Indefinite Integrals

ACTIVITY 5.3



- 1** Evaluate each of the following integrals.

a $\int (x^2 + \sqrt{x} - e^x) dx$	b $\int x^2 dx + \int \sqrt{x} dx - \int e^x dx$
c $\int (2x-1)^2 dx$	d $4 \int x^2 dx - 4 \int x dx + \int dx$
e $\int \left(3x^{\frac{1}{2}} + x^{\frac{3}{2}} + \frac{1}{\sqrt{x}} - e^{-x} \right) dx$	f $3 \int x^{\frac{1}{2}} dx + \int x^{\frac{3}{2}} dx + \int \frac{1}{\sqrt{x}} dx - \int e^{-x} dx$
- 2** You remember that differentiation is a distributive process over addition. Is integration distributive in the same way? Justify your answer by considering the integrals in Problem 1 above.
- 3** You know that several functions may have the same derivative, for instance, x^2 , $x^2 + 5$, $x^2 + 2$, $x^2 + 3$,... have derivative $2x$. What is the geometrical interpretation of $\int 2x dx$?

Using **Activity 5.3** and what you have done so far, you have the following properties of the indefinite integral.

Properties of the Indefinite Integral

- 1 $\int f'(x)dx = f(x) + c$ or $\int \frac{d}{dx} f(x)dx = f(x) + c.$
- 2 $\frac{d}{dx} \int f(x)dx = f(x).$
- 3 $\int kf(x)dx = k \int f(x)dx.$
- 4 $\int (f(x) + g(x))dx = \int f(x)dx + \int g(x)dx$
- 5 $\int (f(x) - g(x))dx = \int f(x)dx - \int g(x)dx.$

Theorem 5.1

If two functions $F(x)$ and $G(x)$ are anti derivatives of the function $f(x)$ in the interval $[a, b]$, then $F(x) = G(x) + c$ for all $x \in [a, b]$, where c is an arbitrary constant.

Proof: $(F(x) - G(x))' = F'(x) - G'(x) = f(x) - f(x) = 0$
 $\Rightarrow F(x) - G(x) = c \Rightarrow F(x) = G(x) + c$

We will explain briefly what we mean by arbitrary constant c ,

$$\int f(x)dx = G(x) + c$$

If you draw one of the integral curves $y = F(x)$ by taking $c = 0$, all the other integral curves $y = F(x) + c$ are obtained by shifting the curve of $y = f(x)$ in the y -direction. Thus you obtain a family of (parallel) curves.

The fact that they are parallel curves means that they have equal slope at $(a, F(a) + c)$. Look at **Figure 5.1** and **Figure 5.2**.

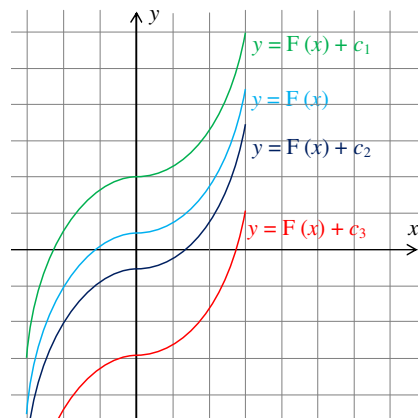

Figure 5.1

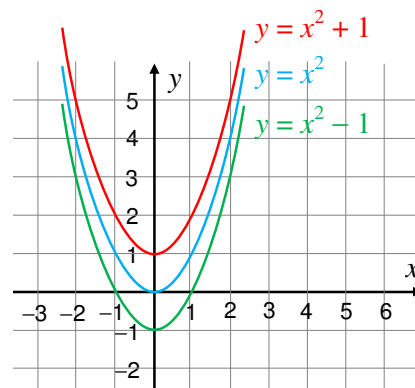

Figure 5.2

The slope of each curve at a is $F'(a)$. Where $F'(a) = F_1'(a) = F_2'(a) = \dots$

Example 11 Let $f(x) = 2x$. Then $\int f(x) dx = x^2 + c$

The slope of $y = x^2$ at $x = 1$ is $\left. \frac{dy}{dx} \right|_{x=1} = 2(1) = 2$

Similarly, the slope of $y = x^2 - 1$ at $x = 1$ is 2, and the slope of $y = x^2 + 1$ at $x = 1$ is 2. [See Figure 5.2].

Exercise 5.4

Evaluate each of the following integrals.

1 $\int \frac{d}{dx}(x^3) dx$

2 $\frac{d}{dx} \int x^3 dx$

3 $\int \left(x^6 + x^{\frac{1}{3}} - x^{-4} + x^{\frac{3}{2}} \right) dx$

4 $\int (\sqrt{x} - 3x^3 + x^{-2} + 2) dx$

5 $\int \frac{x^3 + x^2 + x + 1}{x^4} dx$

6 $\int \frac{(x+1)^2}{\sqrt{x}} dx$

7 $\int \frac{(z^4 + z^3 - 2z^2 + z + 1)}{z^2} dz$

8 $\int (x-1)(x^2 + x + 1) dx$

9 $\int \frac{(t^2 - 3t + 4)}{t} dt$

10 $\int \left(\frac{x+1}{x^2} \right) dx$

11 $\int \left(e^x - e^{-x} + \frac{1}{x} \right) dx$

12 $\int \frac{(e^x - 1)(e^x - 2)}{\sqrt{e^x}} dx$

13 $\int \left(2x^3 + e^{2x} - \frac{1}{2x} \right) dx$

14 $\int e^x (1 - e^x)^2 dx$

15 $\int \left(3^{1-2x} + \frac{1}{\sqrt{2^x}} + \frac{1}{e^{2x}} \right) dx$

Integration of simple trigonometric functions

You know that $\int \frac{d}{dx} f(x) dx = f(x) + c$

From **Activity 5.2** you observed that $\frac{d}{dx} (\sin x) = \cos x$

$$\Rightarrow \int \frac{d}{dx} (\sin x) dx = \int \cos x dx$$

$$\Rightarrow \int \cos x dx = \sin x + c$$

Therefore, using the derivatives of simple trigonometric functions you obtain,

$$\int \sin x \, dx = -\cos x + c$$

$$\int \sec^2 x \, dx = \tan x + c$$

$$\int \csc^2 x \, dx = -\cot x + c$$

Similarly, $\frac{d}{dx}(\sec x) = \sec x \tan x$ and

$$\frac{d}{dx}(\csc x) = -\csc x \cot x$$

Thus, $\int \sec x \tan x \, dx = \sec x + c$ and

$$\int \csc x \cot x \, dx = -\csc x + c$$

Using the properties of indefinite integrals, you have the following integrals of trigonometric functions.

$$\int k \sin x \, dx = -k \cos x + c$$

$$\int \sin(ax+b) \, dx = -\frac{1}{a} \cos(ax+b) + c; \text{ where } a \neq 0$$

Example 12 $\int \cos(5x) \, dx = \frac{1}{5} \sin(5x) + c$ because

$$\frac{d}{dx} \left(\frac{1}{5} \sin(5x) + c \right) = \frac{1}{5} \frac{d}{dx} \sin(5x) = \frac{1}{5} \times \cos(5x) \times 5 = \cos(5x).$$

Example 13 $\int \sec^2(3x+7) \, dx = \frac{1}{3} \tan(3x+7) + c$ because

$$\frac{d}{dx} \left(\frac{1}{3} \tan(3x+7) + c \right) = \frac{1}{3} \frac{d}{dx} \tan(3x+7) = \frac{1}{3} \sec^2(3x+7) \times 3 = \sec^2(3x+7).$$

Exercise 5.5

Integrate each of the following expressions with respect to x .

1 $3 \sin(x)$

2 $\cos(2x)$

3 $\sin(4x - 1)$

4 $3 \cos\left(4x + \frac{\pi}{3}\right)$

5 $\sin(3x) + \cos(4x)$

6 $\sec^2(2x + 1)$

7 $\csc(2x) \cot(2x)$

8 $\sec\left(2x - \frac{\pi}{4}\right) \tan\left(2x - \frac{\pi}{4}\right)$

5.2 TECHNIQUES OF INTEGRATION

In differential calculus you have seen different rules such as: the addition, subtraction, product, quotient and chain rules. Also, in the reverse process, integration, you have different methods. The most commonly used methods are: substitution, partial fractions, and integration by parts.

5.2.1 Integration by Substitution

Integration by substitution is a counter part to the **chain rule of differentiation**. It is a method of finding integrals by changing variables. The integral expressed in a new variable may be simpler to evaluate or changed from the unfamiliar integral form to a better understood form. This method is based on a change of variable equation and the chain rule. The change of the variable is helpful to make unfamiliar integral form to the integral form you can recognize.

Consider $\int 2x(x^2 + 1)^5 dx$

Let $u = x^2 + 1$, then $\frac{du}{dx} = \frac{d}{dx}(x^2 + 1) = 2x \Rightarrow du = 2x dx$

$$\Rightarrow \int 2x(x^2 + 1)^5 dx = \int u^5 du = \frac{u^6}{6} + c$$

But, $u = x^2 + 1$.

Thus, $\int 2x(x^2 + 1)^5 dx = \frac{(x^2 + 1)^6}{6} + c$

In this integration, you change the variable from x to u .

You remember that if u is a function of x , then for a function $f(u)$,

$$\begin{aligned} \frac{d}{dx} f(u) &= \frac{du}{dx} f'(u) \Rightarrow \int \frac{d}{dx} f(u) dx = f(u) + c \\ &\Rightarrow \int \frac{du}{dx} f'(u) dx = f(u) + c \Rightarrow \int f'(u) \frac{du}{dx} dx = \int f'(u) du \end{aligned}$$

Example 1 Find $\int x \sqrt{x^2 + 5} dx$

Solution Let $u = x^2 + 5$, then $\frac{du}{dx} = \frac{d}{dx}(x^2 + 5) = 2x \Rightarrow \frac{1}{2} du = x dx$

$$\begin{aligned} \text{Hence, } \int x \sqrt{x^2 + 5} dx &= \int \sqrt{x^2 + 5} x dx = \frac{1}{2} \int \sqrt{u} du = \frac{1}{2} \frac{u^{\frac{3}{2}}}{\frac{3}{2}} + c = \frac{1}{3} u^{\frac{3}{2}} + c \\ &\Rightarrow \int x \sqrt{x^2 + 5} dx = \frac{1}{3} (x^2 + 5) \sqrt{x^2 + 5} + c \end{aligned}$$

Example 2 For each of the following expressions suggest the variable of substitution and integrate with respect to x .

a $x^2 (5x^3 - 2)^9$	b $\cos x e^{\sin x}$	c $x e^{x^2}$
d $\frac{x}{x^2 + 7}$	e $\cos^3 x \sin x$	f $\sqrt{x} \sqrt{1+x} \sqrt{x}$

Solution Rewrite the integral using u as the variable of substitution.

a $\int x^2 (5x^3 - 2)^9 dx.$

Here, the factor of the integrand, x^2 is the derivative of $\frac{1}{15}(5x^3 - 2)$

$$\text{Thus, } u = 5x^3 - 2 \Rightarrow \frac{du}{dx} = \frac{d}{dx}(5x^3 - 2) = 15x^2$$

$$\Rightarrow \frac{1}{15} du = x^2 dx \Rightarrow \int x^2 (5x^3 - 2)^9 dx = \frac{1}{15} \int u^9 du = \frac{1}{15} \left(\frac{u^{10}}{10} \right) + c$$

$$\Rightarrow \int x^2 (5x^3 - 2)^9 dx = \frac{1}{150} (5x^3 - 2)^{10} + c$$

b $\int \cos x e^{\sin x} dx$

You know that $\frac{d}{dx}(\sin x) = \cos x$.

Hence, $u = \sin x \Rightarrow du = \cos x dx$

$$\Rightarrow \int \cos x e^{\sin x} dx = \int e^u du = e^u + c \Rightarrow \int \cos x e^{\sin x} dx = e^{\sin x} + c$$

c $\int x e^{x^2} dx$

$$u = x^2 \Rightarrow \frac{du}{dx} = 2x \Rightarrow \frac{1}{2} du = x dx$$

$$\Rightarrow \int x e^{x^2} dx = \frac{1}{2} \int e^u du = \frac{1}{2} e^u + c \Rightarrow \int x e^{x^2} dx = \frac{1}{2} e^{x^2} + c$$

Also, observe that, $\frac{d}{dx}(e^{x^2}) = 2x e^{x^2}$

Hence, $u = e^{x^2} \Rightarrow \frac{du}{dx} = 2x e^{x^2}$

$$\Rightarrow \frac{1}{2} du = x e^{x^2} dx \Rightarrow \int x e^{x^2} dx = \frac{1}{2} \int du = \frac{1}{2} u + c$$

$$\Rightarrow \int x e^{x^2} dx = \frac{1}{2} e^{x^2} + c$$

$$\begin{aligned}
 \mathbf{d} \quad & \int \frac{x}{x^2+7} dx; u = x^2 + 7 \\
 & \Rightarrow \frac{du}{dx} = 2x \Rightarrow \frac{1}{2} du = x dx \Rightarrow \int \frac{x}{x^2+7} dx = \frac{1}{2} \int \frac{1}{u} du = \frac{1}{2} \ln|u| + c \\
 & \Rightarrow \int \frac{x}{x^2+7} dx = \frac{1}{2} \ln|x^2+7| + c = \ln\sqrt{x^2+7} + c
 \end{aligned}$$

$$\begin{aligned}
 \mathbf{e} \quad & \int \cos^3 x \sin x dx \\
 & u = \cos x \Rightarrow \frac{du}{dx} = -\sin x \Rightarrow -du = \sin x dx \\
 & \Rightarrow \int \cos^3 x \sin x dx = -\int u^3 du = \frac{-u^4}{4} + c \Rightarrow \int \cos^3 x \sin x dx = \frac{-\cos^4 x}{4} + c
 \end{aligned}$$

$$\begin{aligned}
 \mathbf{f} \quad & \int \sqrt{x} \sqrt{1+x\sqrt{x}} dx \\
 & u = 1 + x\sqrt{x} \Rightarrow \frac{du}{dx} = \frac{d}{dx} \left(1 + x^{\frac{3}{2}} \right) = \frac{3}{2} x^{\frac{1}{2}} \Rightarrow \frac{2}{3} du = \sqrt{x} dx \\
 & \int \sqrt{x} \sqrt{1+x\sqrt{x}} dx = \frac{2}{3} \int \sqrt{u} du = \frac{2}{3} \left(\frac{2}{3} \right) u^{\frac{3}{2}} + c = \frac{4}{9} u^{\frac{3}{2}} + c = \frac{4}{9} (1+x\sqrt{x})^{\frac{3}{2}} + c
 \end{aligned}$$

Example 3 Find $\int (3x-2)\sqrt{x+6} dx$.

Solution Here, $3x-2$ is not a constant times the derivative of $x+6$ or vice versa.

But you can still use substitution as follows.

$$u = x + 6 \Rightarrow x = u - 6 \Rightarrow 3x - 2 = 3(u - 6) - 2 = 3u - 20; u = x + 6 \Rightarrow du = dx$$

$$\text{Thus, } \int (3x-2)\sqrt{x+6} dx = \int (3u-20)\sqrt{u} du = \int 3u\sqrt{u} - 20\sqrt{u} du$$

$$\begin{aligned}
 & = 3 \int u^{\frac{3}{2}} du - 20 \int u^{\frac{1}{2}} du = 3 \frac{u^{\frac{5}{2}}}{\frac{5}{2}} + c_1 - 20 \frac{u^{\frac{3}{2}}}{\frac{3}{2}} + c_2 = \frac{6}{5} u^2 \sqrt{u} - \frac{40}{3} u \sqrt{u} + c \\
 & \Rightarrow \int (3x-2)\sqrt{x+6} dx = \frac{6}{5} (x+6)^2 \sqrt{x+6} - \frac{40}{3} (x+6) \sqrt{x+6} + c.
 \end{aligned}$$

Example 4 Evaluate $\int \frac{3}{2x+1} dx$.

Solution $u = 2x + 1 \Rightarrow \frac{1}{2} du = dx$

$$\Rightarrow \int \frac{3}{2x+1} dx = \frac{3}{2} \int \frac{1}{u} du = \frac{3}{2} \ln|u| + c \Rightarrow \int \frac{3}{2x+1} dx = \frac{3}{2} \ln|2x+1| + c$$

Example 5 Evaluate the following integrals

$$\mathbf{a} \quad \int f(x)f'(x) dx \qquad \mathbf{b} \quad \int \frac{f'(x)}{f(x)} dx, f(x) \neq 0$$

Solution $u = f(x) \Rightarrow \frac{du}{dx} = \frac{d}{dx} f(x) = f'(x) \Rightarrow du = f'(x) dx$

$$\mathbf{a} \quad \int f(x)f'(x) dx = \int u du = \frac{u^2}{2} + c \Rightarrow \int f(x)f'(x) dx = \frac{(f(x))^2}{2} + c$$

$$\mathbf{b} \quad \int \frac{f'(x)}{f(x)} dx = \int \frac{1}{u} du = \ln|u| + c \Rightarrow \int \frac{f'(x)}{f(x)} dx = \ln|f(x)| + c.$$

Example 6 Using $\int \frac{f'(x)}{f(x)} dx$, show that $\int \tan x dx = -\ln|\cos x| + c$.

Solution $\int \tan x dx = \int \frac{\sin x}{\cos x} dx = -\int \frac{(\cos x)'}{\cos x} dx = -\ln|\cos x| + c$

Example 7 Using a suitable identity, find $\int \sin^2 x dx$.

Solution By writing $\cos(2x) = \cos^2 x - \sin^2 x = 1 - 2\sin^2 x$, you have,

$$\sin^2 x = \frac{1 - \cos(2x)}{2}$$

$$\Rightarrow \int \sin^2 x dx = \int \frac{1 - \cos(2x)}{2} dx = \int \frac{1}{2} dx - \frac{1}{2} \int \cos(2x) dx$$

$$\text{But } \int \cos(2x) dx = \frac{1}{2} \sin(2x) + c. \quad \textit{Explain!}$$

$$\Rightarrow \int \sin^2 x dx = \frac{1}{2} x - \frac{1}{4} \sin(2x) + c.$$

Example 8 Find $\int 2^{4x-1} dx$ using the method of substitution.

Solution $u = 4x - 1 \Rightarrow \frac{du}{dx} = 4 \Rightarrow \frac{1}{4} du = dx$

$$\Rightarrow \int 2^{4x-1} dx = \frac{1}{4} \int 2^u du = \frac{1}{4} \left(\frac{2^u}{\ln 2} \right) = \frac{2^u}{\ln 16} + c \Rightarrow \int 2^{4x-1} dx = \frac{2^{4x-1}}{\ln 16} + c.$$

Can you do this without using substitution?

Look at the following.

$$\int 2^{4x-1} dx = \int \frac{16^x}{2} dx = \frac{1}{2} \int 16^x dx = \frac{1}{2} \left(\frac{16^x}{\ln 16} \right) + c = \frac{2^{4x-1}}{\ln 16} + c$$

Example 9 Find $\int x^2 \cos(x^3 + 1) dx$

Solution $u = x^3 + 1 \Rightarrow \frac{1}{3} du = x^2 dx \Rightarrow \int x^2 \cos(x^3 + 1) dx = \frac{1}{3} \int \cos u du = \frac{1}{3} \sin u + c$

$$\int x^2 \cos(x^3 + 1) dx = \frac{1}{3} \sin(x^3 + 1) + c.$$

Example 10 Evaluate $\int \frac{x}{\sqrt{x^2 + a^2}} dx$

Solution Let $u = x^2 + a^2 \Rightarrow \frac{du}{dx} = \frac{d}{dx}(x^2 + a^2) = 2x \Rightarrow \frac{1}{2} du = x dx$

$$\text{Thus, } \int \frac{x}{\sqrt{x^2 + a^2}} dx = \frac{1}{2} \int \frac{du}{\sqrt{u}} = \sqrt{u} + c \Rightarrow \int \frac{x}{\sqrt{x^2 + a^2}} dx = \sqrt{x^2 + a^2} + c.$$

Example 11 Evaluate $\int \frac{1}{x \ln x} dx$

Solution In the product $\left(\frac{1}{x}\right)\left(\frac{1}{\ln x}\right)$, the factor $\frac{1}{x}$ is the derivative of $\ln x$.

Therefore, $u = \ln x$ so that $\int \frac{du}{u} = \ln |u| + c = \ln |\ln |x|| + c$

Exercise 5.6

1 Integrate each of the following expressions with respect to x .

a $2x(x^2 + 1)^3$

b $x\sqrt{x^2 + 4}$

c $x^2\sqrt{x^3 + 1}$

d $(2x + 1)\sqrt{x^2 + x + 9}$

e $\sin x \cos x$

f $(2x + 3)e^{(x^2 + 3x + 4)}$

g $\sin x e^{\cos x}$

h $(x + 2)\sqrt{x - 3}$

2 Find each of the following integrals using the suggested substitution.

a $\int \sqrt{3x - 2} dx; u = 3x - 2$

b $\int x\sqrt{1 - 5x^2} dx; u = 1 - 5x^2$

c $\int \sin(2x) dx; u = 2x$

d $\int (1 - 4x) dx; u = 1 + x$

e $\int x(x^2 - 3)^5 dx; u = x^2 - 3$

f $\int x^2(2 + 3x^3) dx; u = 3x^3 + 2$

g $\int e^x \sqrt{1 + e^x} dx; u = 1 + e^x$

h $\int \sin x \cos^{10} x dx; u = \cos x$

i $\int \sqrt{4x - 3} dx; u = x - 3$

j $\int \frac{1}{(1 - x)^{\frac{1}{3}}} dx; u = 1 - x$

k	$\int 3^{\frac{1}{x}} x^{-2} dx; u = \frac{1}{x}$	l	$\int 3^{0.6x+\pi} dx; u = 0.6x + \pi$
m	$\int \cos(3-x) dx; u = 3-x$	n	$\int x \sin(x^2+7) dx; u = x^2+7$
o	$\int \frac{4x-5}{2x^2-5x+4} dx;$ $u = 2x^2-5x+4$	p	$\int \frac{x+1}{\sqrt{x+3}} dx; u = x+3$ or $u = x+1$
q	$\int (3+2x)^{12} dx; u = 3+2x$	r	$\int \tan x \sec^2 x dx; u = \tan x$
s	$\int \sin(2x+\pi) dx; u = 2x+\pi$	t	$\int 5^{x\sqrt{x}} \sqrt{x} dx; u = x\sqrt{x}$
u	$\int \frac{x}{\sqrt{x^2+5}} dx; u = x^2+5$	v	$\int (2x-3) \sqrt{x+3} dx; u = x+3$

3 Evaluate each of the following integrals.

a	$\int x^3(x^4+5) dx$	b	$\int \left(1 - \frac{1}{x^2}\right) \left(x + \frac{1}{x}\right) dx$
c	$\int (2^{x^2}) x dx$	d	$\int \cot x dx$
e	$\int \sin x \sqrt{1-\cos x} dx$	f	$\int e^x \sqrt{4+e^x} dx$
g	$\int (ax+b)^n dx$	h	$\int \cos(4x+3) dx$
i	$\int 3^x (1-3^{(x+1)})^9 dx$	j	$\int \frac{4}{4x-2} dx$
k	$\int \frac{1}{ax+b} dx$	l	$\int \frac{1}{(ax+b)^n} dx$
m	$\int \frac{x}{\sqrt{x^2+1}} dx$	n	$\int x^2(x^3-8) dx$
o	$\int \frac{e^{\sqrt{t}}}{\sqrt{t}} dt$	p	$\int \frac{2^{\sqrt{y}}}{\sqrt{y}} dy$
q	$\int x\sqrt{3+5x} dx$	r	$\int \frac{\sin t}{\sqrt{3+\cos t}} dt$
s	$\int \frac{\sin(2t)}{1-\cos(2t)} dt$	t	$\int x e^{x^2+7} dx$
u	$\int \frac{4x-1}{1-2x+4x^2} dx$	v	$\int (3x+1)(3x^2+2x+5)^6 dx$
w	$\int (x-1) \sqrt[3]{(x^2-2x+3)^2} dx$	x	$\int \cos x \sin^{10} x dx$

5.2.2 Integration by partial fractions

Decomposition of a rational expression into partial fractions was discussed in grade 11. In this section, to find the integrals of some rational expressions, you use partial fractions along with the method of substitution.

ACTIVITY 5.4



- 1** Decompose each of the following rational expressions into partial fractions

a $\frac{1}{x(x+1)}$

b $\frac{x}{x^3 - 3x + 2}$

c $\frac{2x-3}{(x-1)^2}$

d $\frac{x^3}{x^2 - 4x + 3}$

e $\frac{x+2}{x^2(x-3)}$

f $\frac{x^2 + 2x + 3}{(x+1)(x^2 - 4)}$

g $\frac{x-1}{(x+1)^2(x+2)}$

- 2** Consider the integral of the rational expression $\frac{x+3}{x+1}$, rewrite this expression as $1 + \frac{2}{x+1}$ by using long division.

$$\Rightarrow \int \frac{x+3}{x+1} dx = \int \left(1 + \frac{2}{x+1}\right) dx = x + 2 \int \frac{1}{x+1} dx = x + 2 \ln|x+1| + c$$

Using this technique of integration, find each of the following integrals.

a $\int \frac{x+2}{x+3} dx$

b $\int \frac{x+2}{4x-3} dx$

c $\int \frac{x}{4x+5} dx$

d $\int \frac{4x-5}{5x-4} dx$

e $\int \frac{1}{(2x-1)^4} dx$

f $\int \left(\frac{x+1}{x-3}\right)^3 dx$

- 3** You know that $\int \left(\frac{1}{x+2} + \frac{3}{x-1}\right) dx = \int \frac{1}{x+2} dx + \int \frac{3}{x-1} dx = \ln|x+2| + 3 \ln|x-1| + c$

Can you evaluate this integral by summing up the expressions?

$$\text{i.e., } \int \left(\frac{1}{x+2} + \frac{3}{x-1}\right) dx = \int \frac{x-1+3(x+2)}{(x+2)(x-1)} dx = \int \frac{4x+5}{(x+2)(x-1)} dx$$

From **Activity 5.4**, you have seen that decomposition into partial fractions together with substitution enables you to evaluate the integrals of some rational expressions.

Example 12 Find $\int \frac{x+5}{x^2+4x+3} dx$

Solution Using partial fractions, you obtain,

$$\begin{aligned}\frac{x+5}{x^2+4x+3} &= \frac{A}{x+1} + \frac{B}{x+3} \Rightarrow \int \frac{x+5}{x^2+4x+3} dx = \int \left(\frac{A}{x+1} + \frac{B}{x+3} \right) dx \\ &= A \ln|x+1| + B \ln|x+3| + c = 2 \ln|x+1| - \ln|x+3| + c\end{aligned}$$

Example 13 Find $\int \frac{x^3+2x^2-x-7}{x^2+x-2} dx$.

Solution The rational expression is an improper fraction, hence before factorizing the denominator we use long division, to obtain

$$\begin{aligned}\int \frac{x^3+2x^2-x-7}{x^2+x-2} dx &= \int \left(x+1 - \frac{5}{x^2+x-2} \right) dx \\ &= \frac{x^2}{2} + x - 5 \int \left(\frac{A}{x+2} + \frac{B}{x-1} \right) dx = \frac{x^2}{2} + x - 5 (A \ln|x+2| + B \ln|x-1|) + c \\ &= \frac{x^2}{2} + x + \frac{5}{3} \ln|x+2| - \frac{5}{3} \ln|x-1| + c = \frac{x^2}{2} + x + \frac{5}{3} [\ln|x+2| - \ln|x-1|] + c \\ &= \frac{x^2}{2} + x + \frac{5}{3} \ln \left| \frac{x+2}{x-1} \right| + c\end{aligned}$$

Example 14 Evaluate $\int \frac{dx}{x^2-9}$

Solution Using partial fractions you have

$$\int \frac{dx}{x^2-9} = \int \frac{A}{x-3} dx + \int \frac{B}{x+3} dx = A \ln|x-3| + B \ln|x+3| + c$$

From partial fractions we calculate the values $A = \frac{1}{6}$ and $B = -\frac{1}{6}$

$$\Rightarrow \int \frac{dx}{x^2-9} = \frac{1}{6} \ln|x-3| - \frac{1}{6} \ln|x+3| + c = \ln \sqrt{\left| \frac{x-3}{x+3} \right|} + c.$$

Exercise 5.7

Use the method of substitution along with partial fractions to evaluate each of the following integrals.

1 $\int \frac{x}{x+5} dx$

2 $\int \frac{4x+1}{x^2-3x+2} dx$

3 $\int \frac{x^2-x-2}{x^2+x-2} dx$

4	$\int \frac{x^2 + 4}{x^2 - 1} dx$	5	$\int \frac{3x + 5}{x + 2} dx$	6	$\int \frac{x}{x^2 - 2x - 8} dx$
7	$\int \frac{x}{(x^2 - 3x - 8)^2} dx$	8	$\int \frac{x^3}{(x + 1)^2(x + 2)} dx$	9	$\int \frac{1}{(x + 2)^2} dx$
10	$\int \frac{x^2 + 2x - 3}{x^2(x^2 - 5x + 6)} dx$				

5.2.3 Integration by parts

The product rule for differentiation is

$$\frac{d}{dx}(f(x) \cdot g(x)) = g(x) \frac{d}{dx} f(x) + f(x) \frac{d}{dx} g(x)$$

This form cannot be expressed as $\frac{du}{dx} f'(x)$.

Hence, it cannot be integrated by the method of substitution.

Integration by parts is a method which is a counter part of the product rule of differentiation.

Integrating both sides of the above expressions gives,

$$\begin{aligned} \int \frac{d}{dx}(f(x) \cdot g(x)) dx &= \int g(x) \frac{d}{dx} f(x) dx + \int f(x) \frac{d}{dx} g(x) dx \\ \Rightarrow f(x) \cdot g(x) &= \int g(x) \frac{d}{dx} f(x) dx + \int f(x) \frac{d}{dx} g(x) dx \\ \Rightarrow \int f(x) \frac{d}{dx} g(x) dx &= f(x) \cdot g(x) - \int g(x) \frac{d}{dx} f(x) dx. \end{aligned}$$

ACTIVITY 5.5



- Differentiate each of the following expressions with respect to x .

a $x \ln x - x + 4$	b $x e^x - e^x - 7$
c $x \cos x - \cos x + 5$	d $e^x (\sin x + \cos x)$
e $x^2 \ln x - x^2$	
- Using the result of **problem 1** above, evaluate each of the following integrals.

a $\int \ln x dx$	b $\int x e^x dx$	c $\int x \sin x dx$
d $\int e^x \sin x dx$	e $\int x \ln x dx$	
- Suppose you want to evaluate $\int x^2 \sin x dx$, which method are you going to apply?

Note:

Let u and v be functions of x i.e. $u = u(x)$ and $v = v(x)$.

$$\text{Then, } \frac{d}{dx}(uv) = v \frac{du}{dx} + u \frac{dv}{dx} \Rightarrow u \frac{dv}{dx} = \frac{d}{dx}(uv) - v \frac{du}{dx}$$

$$\Rightarrow \int u \frac{dv}{dx} dx = \int \frac{d}{dx}(uv) dx - \int v \frac{du}{dx} dx \Rightarrow \int u \frac{dv}{dx} dx = uv - \int v \frac{du}{dx} dx$$

$$\text{In short, } \int u dv = uv - \int v du$$

In this method, you should be able to choose “parts” u and dv .

Examples 15 Evaluate $\int x e^x dx$

Solution Here $x e^x = u dv$.

Now, decide which part should be u and which part should be dv .

Suppose $u = x$ and $dv = e^x$, then

$$\frac{du}{dx} = 1, \text{ and } \int dv = \int e^x dx \Rightarrow v = e^x$$

$$\Rightarrow \int x e^x dx = uv - \int v \frac{du}{dx} dx = x e^x - \int e^x dx = x e^x - e^x + c$$

If $u = e^x$ and $dv = x$.

$$\text{Then, } \frac{du}{dx} = e^x \text{ and } v = x^2 = \int x e^x dx = uv - \int v \frac{du}{dx} dx = e^x \cdot x^2 - \int x^2 e^x dx$$

This is more complex than the original integral. Hence, it is sometimes helpful to consider u to be the polynomial factor.

In the expression $x e^x$, x is the polynomial factor.

Example 16 Evaluate $\int \ln x dx$.

Solution In $\ln x$, what is the polynomial factor?

$$\text{Let } u = \ln x \text{ and } dv = dx. \text{ Then, } du = \frac{1}{x} \text{ and } v = x.$$

$$\text{Thus, } \int \ln x dx = x \ln x - \int x \left(\frac{1}{x} \right) dx = x \ln x - \int dx = x \ln x - x + c$$

Example 17 Evaluate $\int \log_2 x dx$

Solution Note that $\log_2 x = \frac{\ln x}{\ln 2}$.

$$\text{Hence } \int \log_2 x dx = \int \frac{\ln x}{\ln 2} dx = \frac{1}{\ln 2} \int \ln x dx = \frac{1}{\ln 2} (x \ln x - x) + c$$

Note:

If $a > 0$ and $a \neq 1$,

$$\begin{aligned} \int \log_a x \, dx &= \int \frac{\ln x}{\ln a} \, dx = \frac{1}{\ln a} \int \ln x \, dx \\ &= \frac{1}{\ln a} (x \ln x - x) + c \end{aligned}$$

Example 18 Evaluate $\int \log(3x+1) \, dx$

Solution Let $u = 3x + 1$, then

$$\begin{aligned} \frac{du}{dx} = 3 &\Rightarrow \frac{1}{3} du = dx \\ \Rightarrow \int \log(3x+1) dx &= \int \frac{\ln(3x+1)}{\ln 10} dx = \frac{1}{3 \ln 10} \int \ln u \, du \\ &= \frac{1}{3 \ln 10} (u \ln u - u) + c \\ &= \frac{1}{3 \ln 10} ((3x+1) \ln(3x+1) - (3x+1)) + c \\ &= \frac{1}{3 \ln 10} ((3x+1) \ln(3x+1) - 3x - 1) + c \end{aligned}$$

Example 19 Evaluate $\int x \sin x \, dx$

Solution $u = x \Rightarrow du = dx$

$$\begin{aligned} \frac{dv}{dx} = \sin x &\Rightarrow v = -\cos x \Rightarrow \int x \sin x \, dx = -x \cos x - \int -\cos x \, dx \\ &= -x \cos x + \sin x + c \end{aligned}$$

Example 20 Evaluate $\int x \ln x \, dx$

Solution $u = \ln x \Rightarrow du = \frac{1}{x}$ and $dv = x \Rightarrow v = \frac{x^2}{2}$

$$\begin{aligned} \Rightarrow \int x \ln x \, dx &= \frac{x^2}{2} \ln x - \int \frac{x^2}{2} \cdot \frac{1}{x} \, dx \\ &= \frac{x^2}{2} \ln x - \frac{1}{2} \int x \, dx = \frac{x^2}{2} \ln x - \frac{1}{2} \cdot \frac{x^2}{2} + c \\ &= \frac{x^2}{2} \ln x - \frac{1}{4} x^2 + c. \end{aligned}$$

Can you assume $u = x$ and $dv = \ln x$?

If you set $u = x$, then $du = dx$ and $dv = \ln x \, dx$

$$\Rightarrow v = x \ln x - x$$

Then, $\int x \ln x \, dx = x(x \ln x - x) - \int (x \ln x - x) \, dx$

$$= x^2 \ln x - x^2 - \int x \ln x \, dx + \int x \, dx$$

$$\Rightarrow 2 \int x \ln x \, dx = x^2 \ln x - x^2 + \frac{x^2}{2} + c$$

$$\Rightarrow \int x \ln x \, dx = \frac{1}{2} x^2 \ln x - \frac{1}{4} x^2 + c.$$

Although this gives you the correct answer, it is safer to set u as $\ln x$.

Example 21 Evaluate $\int x^r \ln x \, dx$; where r is a real number different from -1 .

Solution What happens if $r = -1$? Are you going to use by parts?

$$\text{If } r = -1, \text{ then, } \int x^r \ln x \, dx = \int \frac{\ln x}{x} \, dx$$

By the method of substitution you have,

$$u = \ln x \Rightarrow du = \frac{1}{x} \, dx,$$

$$\int \frac{\ln x}{x} \, dx = \int u \, du = \frac{u^2}{2} + c \Rightarrow \int \frac{\ln x}{x} \, dx = \frac{\ln^2 x}{2} + c$$

$$\text{If } r \neq -1, \text{ then } u = \ln x \Rightarrow du = \frac{1}{x} \, dx$$

$$dv = x^r \, dx \Rightarrow v = \frac{x^{r+1}}{r+1}.$$

Then, $\int x^r \ln x \, dx = uv - \int v \, du$

$$= (\ln x) \frac{x^{r+1}}{r+1} - \int \frac{x^{r+1}}{r+1} \left(\frac{1}{x} \right) dx$$

$$= \frac{x^{r+1}}{r+1} \ln x - \frac{x^{r+1}}{(r+1)^2} + c$$

Example 22 Evaluate $\int x^2 \log_3 x \, dx$

Solution
$$\int x^2 \log_3 x \, dx = \frac{1}{\ln 3} \int x^2 \ln x \, dx$$

$$= \frac{1}{\ln 3} \left[\frac{x^3}{3} \ln x - \frac{x^3}{9} \right] + c. \text{ Why?}$$

Example 23 Find $\int e^x \sin x \, dx$.

Solution Choose $u = e^x$ and $dv = \sin x$

Then, $du = e^x \, dx$ and $v = -\cos x$.

$$\Rightarrow \int e^x \sin x \, dx = -e^x \cos x - \int -\cos x e^x \, dx = -e^x \cos x + \int \cos x e^x \, dx$$

$\int e^x \cos x \, dx$ has the same form as $\int e^x \sin x \, dx$.

Hence you apply integration by parts for a second time.

$$u = e^x \Rightarrow du = e^x \, dx \text{ and } dv = \cos x \Rightarrow v = \sin x$$

$$\Rightarrow \int \cos x e^x \, dx = e^x \sin x - \int \sin x e^x \, dx$$

$$\text{But } \int e^x \sin x \, dx = -e^x \cos x + \int \cos x e^x \, dx = -e^x \cos x + e^x \sin x - \int \sin x e^x \, dx$$

By collecting like terms, you obtain

$$2 \int e^x \sin x \, dx = -e^x \cos x + e^x \sin x + c$$

$$\Rightarrow \int e^x \sin x \, dx = \frac{1}{2} e^x (\sin x - \cos x) + c.$$

In the integral $\int f(x)g(x) \, dx$, if $f(x)$ is a transcendental function (exponential, trigonometric or logarithmic function) and $g(x)$ is a polynomial function, use the substitution $u = g(x)$ and $dv = f(x) \, dx$ for integration by parts.

Exercise 5.8

Integrate each of the following expressions with respect to x using the method of integration by parts.

- | | | |
|--------------------------|------------------------------|-------------------------------|
| 1 $x e^{1-x}$ | 2 $x \cos x$ | 3 $x e^{3x+1}$ |
| 4 $x^2 e^x$ | 5 $4x \sin x$ | 6 $e^x \cos(2x)$ |
| 7 $e^{3x} \sin x$ | 8 $e^{-x} \sin(2x)$ | 9 $\ln(4x)$ |
| 10 $x^3 \ln x$ | 11 $e^x(x+2)$ | 12 $x^2 \sin x$ |
| 13 $x^2 \ln(2x)$ | 14 $x \ln(nx); n > 0$ | 15 $x \sin(nx); n > 0$ |

5.3 DEFINITE INTEGRALS, AREA AND THE FUNDAMENTAL THEOREM OF CALCULUS



OPENING PROBLEM

The area under the curve of $y = 5 - 2x^2 + 4x^3 - x^5$ from $x = -\frac{1}{2}$ to $x = 1\frac{1}{2}$ is divided into n strips. Each strip is approximated by a rectangle of width $\frac{1}{n}$ as shown by the following figure.

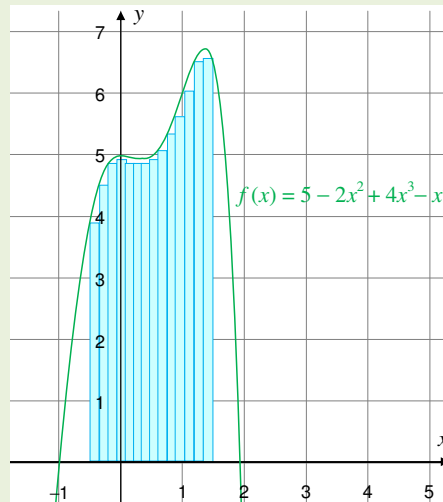

Figure 5.3

What is the limit of the sum of the areas of all the rectangles as n approaches infinity?

5.3.1 The Area of a Region under a Curve

From geometry, you know how to determine the areas of certain plane figures such as triangles, rectangles, parallelograms, trapeziums, different regular polygons, circles or combinations of parts of circles and polygons.

In this topic, you shall determine the area of a region under the curve of a non-negative function $y = f(x)$ that is continuous on a closed interval $[a, b]$. You divide the region into n stripes approximated by n rectangles of uniform width Δx ,

where $\Delta x = \frac{b-a}{n}$ formed by vertical lines through $a = x_0, x_1, x_2, \dots, x_n = b$; where

$$a = x_0 < x_1 < x_2 < \dots < x_n = b, x_1 - x_0 = x_2 - x_1 = x_3 - x_2 = \dots = (x_n - x_{n-1}) = \Delta x$$

Look at [Figure 5.4](#).

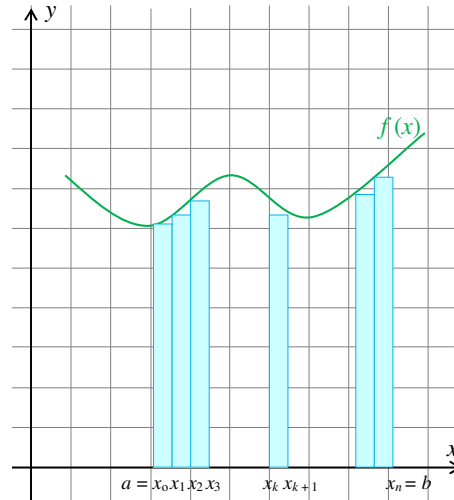

Figure 5.4

As the value of n gets larger and larger the rectangles get thinner and thinner. i.e. the rectangles rise up to fill in the region.

Thus, the area of the region will be the limiting value of the sum of the areas of the rectangles. This is one of the different techniques of finding the area of a region under a curve.

ACTIVITY 5.6



1 Let $x_0, x_1, x_2, \dots, x_n \in [a, b]$ with $a = x_0 < x_1 < x_2 < \dots < x_n = b$.

The finite set $P = \{x_0, x_1, x_2, \dots, x_n\}$ is said to be a **partition** of $[a, b]$.

For instance $\left\{0, \frac{1}{4}, \frac{1}{2}, \frac{3}{4}, 1\right\}$ is a partition of $[0, 1]$.

Find at least three different partitions of $[0, 1]$

2 The n - sub intervals in which the partition P divides $[a, b]$ are:

$$[x_0, x_1], [x_1, x_2], [x_2, x_3], \dots, [x_{n-1}, x_n].$$

The length of the k^{th} sub interval $[x_{k-1}, x_k]$ is $x_k - x_{k-1}$.

a Divide $[0, 1]$ into 5 - sub intervals of equal lengths

b Divide $[3, 5]$ into 10 - sub intervals of equal lengths.

c Divide $[0, 1]$ into n - sub intervals of equal lengths.

3 Consider the area under the line $y = x + 1$ from $x = 0$ to $x = 1$. Divide the interval

$[0, 1]$ into n - sub intervals each of length $\frac{1}{n}$. **Figure 5.5** below shows a sketch of

the inscribed rectangle.

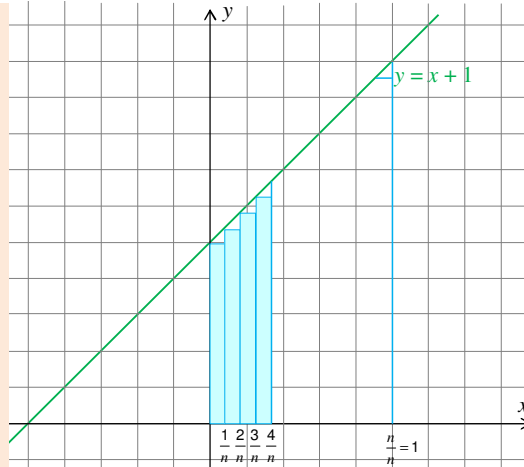

Figure 5.5

- i** Find the sum of the areas of the rectangles when
- a** $n = 3$ **b** $n = 5$ **c** $n = 10$
- ii** Find the limiting value of the sum of the areas of the rectangles, as $n \rightarrow \infty$
- 4** Repeat Problem 3, if the rectangles are circumscribed instead of being inscribed. Look at **Figure 5.6**.

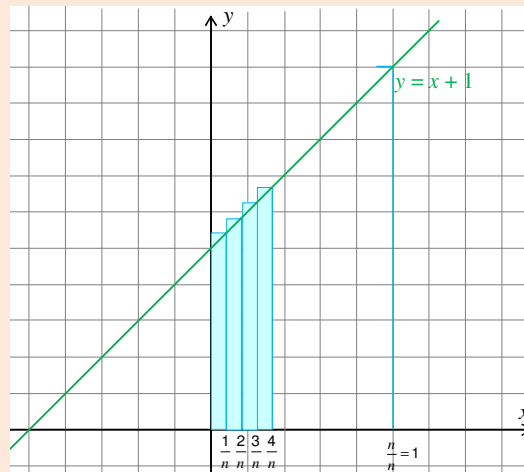

Figure 5.6

Using the concept developed in the activity, consider a function f which is non-negative and continuous on $[a, b]$. Then the area under the curve of $y = f(x)$ and the x -axis between the lines $x = a$ and $x = b$ is calculated as follows.

Divide the interval $[a, b]$ into n sub intervals

$[x_0, x_1], [x_1, x_2], [x_2, x_3], \dots, [x_{n-1}, x_n]$ each of length $\Delta x = \frac{b-a}{n}$

Let n rectangles each of width $\frac{b-a}{n}$ be inscribed in the region as shown in **Figure 5.7**.

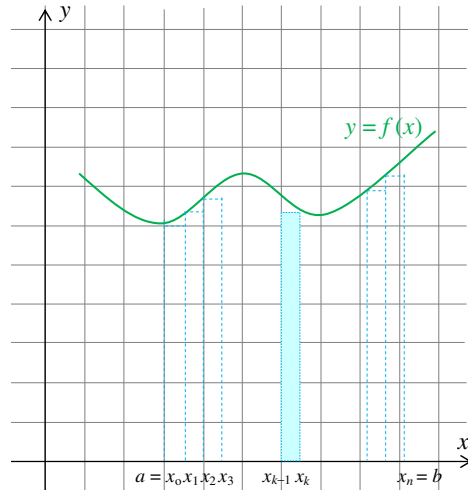

Figure 5.7

Let $z_k \in [x_{k-1}, x_k]$ such that $f(z_k)$ is the height of the k^{th} rectangle.

Let ΔA_k be the area of the k^{th} rectangle.

$$\text{Then, } \Delta A_k = \left(\frac{b-a}{n} \right) f(z_k)$$

Let A be the sum of the n - rectangles.

$$\text{Then, } A = \sum_{k=1}^n \Delta A_k = \sum_{k=1}^n \frac{b-a}{n} f(z_k) = \left(\frac{b-a}{n} \right) \sum_{k=1}^n f(z_k)$$

The area A of the region is the limiting value of A , when $n \rightarrow \infty$.

$$\text{i.e. } A = \lim_{n \rightarrow \infty} A_n = \lim_{n \rightarrow \infty} \frac{b-a}{n} \sum_{k=1}^n f(z_k)$$

Definition 5.3

- 1 The sum $\sum_{k=1}^n f(z_k) \Delta x$ is said to be the integral sum of the function f in the interval $[a, b]$.
- 2 If $\lim_{n \rightarrow \infty} \sum_{k=1}^n f(z_k) \Delta x$ exists and is equal to I , then I is said to be the definite integral of f over the interval $[a, b]$ and is denoted by $I = \int_a^b f(x) dx$. a and b are said to be the **lower** and **upper limits** of integration, respectively.

Example 1 Find the area of the region enclosed by the graph of $f(x) = x^2$ and the x -axis between the lines $x = 0$ and $x = 1$.

Solution

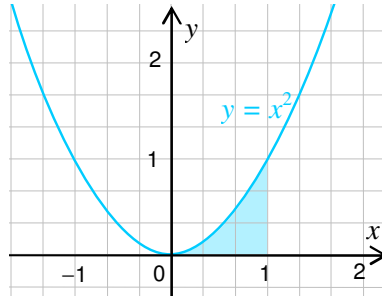

Figure 5.8

Using the definition, calculate the area of the region as follows.

$$A = \int_a^b f(x) dx \Rightarrow \int_a^b x^2 dx = \lim_{n \rightarrow \infty} \sum_{k=1}^n f(z_k) \Delta x$$

$$\text{Where } \Delta x = \frac{1-0}{n} = \frac{1}{n} \text{ and } z_k = \frac{k-1}{n} \Rightarrow f(z_k) = \left(\frac{k-1}{n}\right)^2$$

$$\begin{aligned} \Rightarrow \sum_{k=1}^n f(z_k) \Delta x &= \sum_{k=1}^n \left(\frac{k-1}{n}\right)^2 \left(\frac{1}{n}\right) = \frac{1}{n^3} \sum_{k=1}^n (k-1)^2 \\ &= \frac{1}{n^3} [0+1+2^2+3^2+\dots+(n-1)^2] \\ &= \frac{1}{n^3} \frac{(n-1)(n)(2(n-1)+1)}{6} = \frac{1}{6n^3} [2n^3 - 3n^2 + n] \\ &= \frac{1}{3} - \frac{1}{2n} + \frac{1}{6n^2} \\ \Rightarrow A = \int_a^b x^2 dx &= \lim_{n \rightarrow \infty} \left(\frac{1}{3} - \frac{1}{2n} + \frac{1}{6n^2}\right) = \frac{1}{3} \end{aligned}$$

Theorem 5.2 Estimate of the definite integral

If the function f is continuous on $[a, b]$, then $\lim_{n \rightarrow \infty} f(z_i) \Delta x$ exists.

That is, the definite integral $\int_a^b f(x) dx$ exists.

Example 2 Show that $\int_0^{\frac{\pi}{2}} \sin x dx$ exists.

Solution $f(x) = \sin x$ is continuous on $\left[0, \frac{\pi}{2}\right]$.

Thus, by the above theorem, the definite integral exists.

Example 3 Show that $\int_{-1}^2 \frac{1}{x} dx$ doesn't exist.

Solution $f(x) = \frac{1}{x}$ is discontinuous at $x = 0$.

$\Rightarrow f$ is not continuous on $[-1, 2] \Rightarrow \int_{-1}^2 \frac{1}{x} dx$ doesn't exist.

Exercise 5.9

- 1** Estimate the area of the region bounded by the graph of $f(x) = x^3$ and the x -axis between the lines $x = 1$ and $x = 2$, by dividing the interval $[1, 2]$ into
 - a** 5 - sub intervals
 - b** 10 - sub intervals
 - c** n - sub interval, of equal lengths.

- 2** Using the definition of area under a curve, determine the area of the region enclosed by the curve $y = f(x)$ and the x -axis between the lines $x = a$ and $x = b$, when
 - a** $f(x) = 3x - 1; a = 1, b = 3$
 - b** $f(x) = x^3; a = 1, b = 2$
 - c** $f(x) = x^2 - 4x; a = 0, b = 4$
 - d** $f(x) = x^2 - 2x + 1; a = 0, b = 2$,

- 3** In each of the following determine whether or not the integral of the function exists on the given interval.
 - a** $f(x) = \tan x; \left[-\frac{\pi}{4}, \frac{\pi}{4}\right]$
 - b** $f(x) = \cos x; \left[-\pi, \frac{3}{2}\right]$
 - c** $f(x) = |x|; [-3, 1]$
 - d** $f(x) = \frac{x}{x^2 - 1}; [-2, 2]$
 - e** $f(x) = \frac{2x}{x^2 - 9}; [-4, 4]$
 - f** $f(x) = \frac{x+1}{x^2 - 4}; [-1, 1]$

- 4** Using the definition, evaluate each of the following definite integrals.
 - a** $\int_1^5 4 dx$
 - b** $\int_0^3 x dx$
 - c** $\int_{-1}^1 (x^2 + 1) dx$
 - d** $\int_{-1}^1 \frac{1}{x^2} dx$
 - e** $\int_{-1}^1 x^3 dx$

- 5** Evaluate $\int_{-\frac{\pi}{2}}^{\frac{\pi}{2}} \sin x dx$. What is this definite integral representing?

- 6** Using the fact $\sum_{x=1}^n x^2 = \sum_{s=1}^n s^2$ show that $\int_a^b f(x) dx = \int_a^b f(s) ds$

- 7** In **Figure 5.9**, the area A of the region is equal to

$$A = A_1 + A_2$$

Use this fact to explain $\int_a^b f(x) dx = \int_a^c f(x) dx + \int_c^b f(x) dx$.

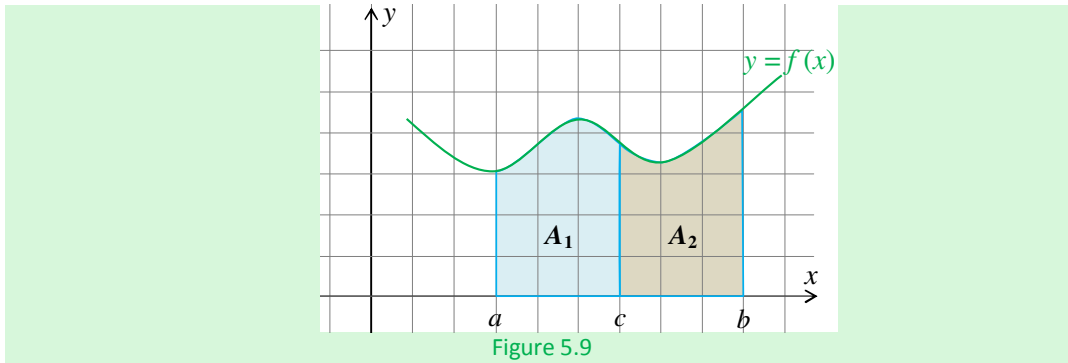

Figure 5.9

5.3.2 Fundamental Theorem of Calculus

Fundamental Theorem of calculus is the statement which asserts that differentiation and integration are inverse operations of each other. To understand this, let f be a function continuous on $[a, b]$. If you first integrate f and then differentiate the result you can retrieve back the original function f . The next theorem allows you to evaluate the definite integral by using the anti derivative of the function to be integrated.

Theorem 5.3 Fundamental theorem of calculus

If f is continuous on the closed interval $[a, b]$ and F is an anti derivative (or indefinite integral) of f .

That is, $F'(x) = f(x)$ for all $x \in [a, b]$, then $\int_a^b f(x) dx = F(b) - F(a)$

Example 4 Evaluate $\int_1^4 x dx$

Solution This value is calculated using the definition of definite integrals.

Here you use the **fundamental theorem of calculus**.

The indefinite integral,

$$F(x) = \int x dx = \frac{x^2}{2} + c \Rightarrow \int_1^4 x dx = F(4) - F(1) = \left(\frac{4^2}{2} + c\right) - \left(\frac{1^2}{2} + c\right) = \frac{15}{2}$$

Observe that evaluating the definite integral using the integral sum is lengthy and complicated as compared to using the **fundamental theorem of calculus**.

Note:

In evaluating $F(b) - F(a)$, the constant of integration cancels out.

Therefore, you write $F(x) \Big|_a^b$ to mean $F(b) - F(a)$

Example 5 Evaluate $\int_1^3 (x^3 + x + 1) dx$

Solution
$$\int_1^3 (x^3 + x + 1) dx = \left. \frac{x^4}{4} + \frac{x^2}{2} + x \right|_1^3 = \left(\frac{3^4}{4} + \frac{3^2}{2} + 3 \right) - \left(\frac{1}{4} + \frac{1}{2} + 1 \right)$$

$$= \frac{81}{4} + \frac{9}{2} + 3 - \frac{1}{4} - \frac{1}{2} - 1 = \frac{80}{4} + \frac{8}{2} + 2 = 26$$

Example 6 Evaluate $\int_{\frac{\pi}{6}}^{\frac{\pi}{3}} \sin x dx$

Solution
$$\int_{\frac{\pi}{6}}^{\frac{\pi}{3}} \sin x dx = -\cos x \Big|_{\frac{\pi}{6}}^{\frac{\pi}{3}} = -\left[\cos \frac{\pi}{3} - \cos \frac{\pi}{6} \right] = -\left[\frac{1}{2} - \frac{\sqrt{3}}{2} \right] = \frac{\sqrt{3} - 1}{2}$$

Example 7 Find the area of the region bounded by the arc of the sine function between $x = 0$ and $x = \pi$.

Solution The area A of this region identified to be the value of the definite integral

$$\int_0^{\pi} \sin x dx.$$

$$\Rightarrow A = \int_0^{\pi} \sin x dx = -\cos x \Big|_0^{\pi} = -[\cos \pi - \cos 0] = -[-1 - 1] = 2$$

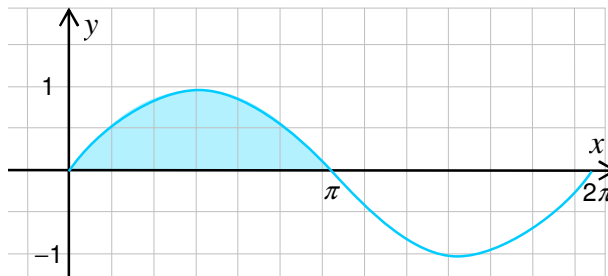

Figure 5.10

Example 8 Evaluate $\int_{-1}^0 e^x dx$

Solution
$$\int_{-1}^0 e^x dx = e^x \Big|_{-1}^0 = e^0 - e^{-1} = 1 - \frac{1}{e} = \frac{e-1}{e}$$

Example 9 Evaluate $\int_1^e \ln x dx$

Solution
$$\int_1^e \ln x dx = x \ln x - x \Big|_1^e = e \ln e - e - (1 \times \ln 1 - 1) = e - e - (0 - 1) = 1$$

Properties of the definite integral

ACTIVITY 5.7



Let $f(x) = x^2$ and $g(x) = 1 - \frac{1}{x}$.

1 Evaluate each of the following definite integrals.

a $\int_1^3 (f(x) + g(x)) dx$ **b** $\int_{-2}^3 f(x) dx$

c $\int_3^1 f(x) dx + \int_1^3 f(x) dx$ **d** $\int_3^3 f(x) dx$

e $4 \int_{-2}^3 f(x) dx$ **f** $\int_1^4 g(x) dx + \int_4^{10} g(x) dx - \int_1^{10} g(x) dx$

2 Let f and g be continuous functions on the closed interval $[a, b]$ and $k \in \mathbb{R}$.

a Evaluate $\int_a^a f(x) dx$ **b** Express $\int_b^a f(x) dx$ in terms of $\int_a^b f(x) dx$

c In the indefinite integral you learned that

$$\int (f(x) \pm g(x)) dx = \int f(x) dx \pm \int g(x) dx \text{ and } \int kf(x) dx = k \int f(x) dx.$$

Does this property hold true for definite integrals? Justify your answer by producing examples.

d You also learned that $\sum_{i=1}^n a_i = \sum_{i=1}^k a_i + \sum_{i=k+1}^n a_i$ for $1 \leq k < n$. Does the equality

$$\int_a^b f(x) dx = \int_a^c f(x) dx + \int_c^b f(x) dx \text{ for } a \leq c < b \text{ hold true?}$$

e In differential calculus you saw that $\frac{d}{dx}(f(x)g(x)) \neq \frac{d}{dx}f(x) \frac{d}{dx}g(x)$.

Give an example to show that $\int_a^b f(x) \cdot g(x) dx \neq \int_a^b f(x) dx \cdot \int_a^b g(x) dx$.

Show that $\int_a^b \frac{f(x)}{g(x)} dx \neq \frac{\int_a^b f(x) dx}{\int_a^b g(x) dx}$ by producing examples.

Properties of the definite Integral

If f and g are continuous on $[a, b]$, $k \in \mathbb{R}$ and $c \in [a, b]$ then

1 $\int_a^a f(x) dx = 0$

2 $\int_b^a f(x) dx = -\int_a^b f(x) dx$

3 $\int_a^b (f(x) \pm g(x)) dx = \int_a^b f(x) dx \pm \int_a^b g(x) dx$

4 $\int_a^b f(x) dx = \int_a^c f(x) dx + \int_c^b f(x) dx$

5 $\int_a^b kf(x) dx = k \int_a^b f(x) dx$

Example 10 Evaluate each of the following integrals using the above properties.

a $\int_3^3 (x^3 + 1) dx$ **b** $\int_{\frac{\pi}{4}}^{\pi} \sin x dx$ **c** $\int_1^2 \left(x - \frac{1}{x^2}\right)^2 dx$

d $\int_1^{\sqrt{2}} \frac{x}{x^2 + 1} dx + \int_{\sqrt{2}}^5 \frac{x}{x^2 + 1} dx$ **e** $\int_{-1}^1 e^{\pi+3x} dx$

Solution

a By **Property 1**, $\int_3^3 (x^3 + 1) dx = 0$

b By **Property 2**,

$$\begin{aligned} \int_{\frac{\pi}{4}}^{\pi} \sin x dx &= -\int_{\pi}^{\frac{\pi}{4}} \sin x dx = \cos x \Big|_{\pi}^{\frac{\pi}{4}} = \cos \frac{\pi}{4} - \cos \pi \\ &= \frac{\sqrt{2}}{2} - (-1) = \frac{\sqrt{2}}{2} + 1 \end{aligned}$$

c By **Property 3** and **Property 5**,

$$\begin{aligned} \int_1^2 \left(x - \frac{1}{x^2}\right)^2 dx &= \int_1^2 \left(x^2 - \frac{2}{x} + \frac{1}{x^4}\right) dx \\ &= \int_1^2 x^2 dx - 2 \int_1^2 \frac{1}{x} dx + \int_1^2 \frac{1}{x^4} dx = \frac{x^3}{3} \Big|_1^2 - 2 \ln|x| \Big|_1^2 - \frac{1}{3x^3} \Big|_1^2 \\ &= \left(\frac{8}{3} - \frac{1}{3}\right) - 2[\ln 2 - \ln 1] - \left[\frac{1}{3(2^3)} - \frac{1}{3}\right] \\ &= \frac{7}{3} - 2 \ln 2 + \frac{7}{24} = \frac{21}{8} - 2 \ln 2. \end{aligned}$$

d By **Property 4**,

$$\begin{aligned} \int_1^{\sqrt{2}} \frac{x}{x^2 + 1} dx + \int_{\sqrt{2}}^5 \frac{x}{x^2 + 1} dx &= \int_1^5 \frac{x}{x^2 + 1} dx \\ &= \frac{1}{2} \ln|x^2 + 1| \Big|_1^5 \\ &= \frac{1}{2} (\ln 26 - \ln 2) = \frac{1}{2} \ln 13. \end{aligned}$$

e $\int_{-1}^1 e^{\pi+3x} dx = \int_{-1}^1 e^{\pi} e^{3x} dx = e^{\pi} \cdot \frac{e^{3x}}{3} \Big|_{-1}^1$

$$\begin{aligned} \int_{-1}^1 e^{\pi+3x} dx &= \int_{-1}^1 e^{\pi} e^{3x} dx = e^{\pi} \int_{-1}^1 e^{3x} dx = e^{\pi} e^{3x} \Big|_{-1}^1 = e^{\pi} \left(\frac{e^3}{3} - \frac{e^{-3}}{3}\right) = \frac{e^{\pi-3}}{3} (e^6 - 1) \\ &= e^{\pi} \left(\frac{e^3}{3} - \frac{e^{-3}}{3}\right) = \frac{e^{\pi-3}}{3} (e^6 - 1). \end{aligned}$$

Change of variable

In evaluating the indefinite integral $\int f(x) dx = F(x)$, the methods you have been using are: substitution, partial fractions and integration by parts.

In the substitution method, the composition function $f \circ g$ is the anti-derivative of $(f \circ g) \cdot g'$.

$$\Rightarrow \int_a^b f(g(x)) \cdot g'(x) dx = F(g(b)) - F(g(a))$$

To evaluate the definite integral by the method of substitution, you transform the integrand as well as the limits of integration.

For this process you have the following theorem.

Theorem 5.4 Change of variables

If the function f is continuous on a closed interval $[c, d]$, the substitution function $u = g(x)$ is differentiable on $[a, b]$ with $g(a) = c$ and $g(b) = d$, then

$$\int_a^b f(g(x)) \cdot g'(x) dx = \int_{g(a)}^{g(b)} f(u) du.$$

ACTIVITY 5.8



- 1 If $-1 \leq x \leq 2$, find the intervals of values for u , when
 - a $u = 3x - 1$
 - b $u = \sqrt{x+1}$
 - c $u = e^{x^2+1}$
 - d $u = 1 - x\sqrt{x^2-1}$
 - e $u = x^2 - x - 2$
- 2 If $\int_a^b \frac{2x}{\sqrt{x^2+4}} dx = \int_c^d \frac{du}{\sqrt{u}}$, find the values of c and d in terms of a and b .
- 3 Evaluate $\int_1^2 (2x+1)\sqrt{x^2+x-2} dx$ using the method of substitution.

Example 11 Evaluate the integral $\int_1^2 x e^{(x^2)} dx$

Solution Using integration by substitution,

$$u = x^2, \frac{du}{dx} = 2x \Rightarrow \frac{1}{2} du = x dx$$

As x varies from 1 to 2, $u = g(x)$ varies from $g(1) = 1$ to $g(2) = 2^2 = 4$.

$$\int_1^2 x e^{x^2} dx = \frac{1}{2} \int_1^4 e^u du = \frac{1}{2} e^u \Big|_1^4 = \frac{1}{2} (e^4 - e)$$

Example 12 Evaluate the integral $\int_{-3}^1 x\sqrt{2x^2+5} dx$.

Solution Here, $u = g(x) = 2x^2 + 5$, $g(-3) = 2(-3)^2 + 5 = 23$,
 $g(1) = 2(1)^2 + 5 = 7$

$$\frac{du}{dx} = \frac{d}{dx}(2x^2 + 5) = 4x \Rightarrow \frac{1}{4} du = x dx$$

$$\int_{-3}^1 x\sqrt{2x^2+5} dx = \frac{1}{4} \int_{23}^7 \sqrt{u} du = \frac{1}{4} \left(\frac{u^{\frac{3}{2}}}{\frac{3}{2}} \right)_{23}^7 = \frac{1}{6} (7\sqrt{7} - 23\sqrt{23}).$$

Example 13 Evaluate $\int_0^{\frac{\pi}{3}} \cos^3 x \sin x dx$

Solution The derivative of $\cos x$ is $-\sin x$ which is a factor of the integrand.

Hence, $u = g(x) = \cos x$.

$$\Rightarrow -du = \sin x dx.$$

$$\int_0^{\frac{\pi}{3}} \cos^3 x \sin x dx = -\int_{g(\frac{\pi}{3})}^{g(0)} u^3 du = -\int_1^{\frac{1}{2}} u^3 du = -\frac{u^4}{4} \Big|_1^{\frac{1}{2}} = -\left(\frac{1}{64} - \frac{1}{4}\right) = \frac{15}{64}$$

Exercise 5.10

In **exercises 1–15** evaluate each of the following definite integrals using the fundamental theorem of calculus. In the exercises, $a, b \in \mathbb{R}$ and $n \in \mathbb{N}$.

1 $\int_{-1}^4 3 dx$

2 $\int_a^b dx$

3 $\int_{-1}^5 -x dx$

4 $\int_1^2 x^5 dx$

5 $\int_a^b x^n dx$

6 $\int_2^1 (x^3 + 5x^2 - 1) dx$

7 $\int_1^2 \sqrt{2x-1} dx$

8 $\int_0^1 2^{3-x} dx$

9 $\int_0^{\frac{\pi}{2}} \sin^2 x dx$

10 $\int_2^3 \frac{1}{x} dx$

11 $\int_0^1 \frac{9}{4x+1} dx$

12 $\int_0^{\sqrt{\pi}} \sin(x^2+3) dx$

13 $\int_{\frac{\pi}{2}}^{\pi} x \sin x dx$

4 $\int_e^{e^3} x \ln x dx$

15 $\int_1^3 \frac{1}{2x^2+x-1} dx$

In **exercises 16 – 25**, evaluate each of the following definite integrals using change of variables.

16 $\int_{-1}^1 \frac{2x+3}{(x^3+3x+4)^6} dx$

17 $\int_{-1}^{\frac{1}{2}} (4x+3)^{10} dx$

18 $\int_{\sqrt{2}}^3 x\sqrt{x^2+7} dx$

- 19 $\int_1^2 x^2 (x^3 - 3)^5 dx$ 20 $\int_4^9 \frac{e^{\sqrt{x}}}{\sqrt{x}} dx$ 21 $\int_0^2 (x-2)\sqrt{x+1} dx$
- 22 $\int_{-1}^0 \frac{x+4}{3x+1} dx$ 23 $\int_{-4}^3 \frac{x+1}{x^2-x-6} dx$ 24 $\int_{-1}^1 \frac{3t^2-1}{e^{t^3-t}} dt$
- 25 $\int_{-1}^1 \frac{e^x}{1+e^x} dx$
- 26 You know that $\int \frac{1}{x^2} dx = -\frac{1}{x} + c$. Is $f(x)$ integrable on $[-2, 2]$? If so, find $\int_{-2}^2 \frac{1}{x^2} dx$.
- 27 Let f be an even function which is continuous in $[-a, a]$ for any real number a .
Then, show that $\int_{-a}^a f(x) dx = 2 \int_0^a f(x) dx$. Use $\int_{-\frac{\pi}{4}}^{\frac{\pi}{4}} \cos x dx$ to verify your work.
- 28 If f is an odd function that is continuous on $[-a, a]$, for any real number a then show that $\int_{-a}^a f(x) dx = 0$
Verify your conclusion by computing the following integrals
- a $\int_{-3}^3 (x^3 + x) dx$ b $\int_{-\frac{\pi}{2}}^{\frac{\pi}{2}} \sin x dx$ c $\int_{-1}^1 \frac{x}{x^2+1} dx$

5.4 APPLICATIONS OF INTEGRAL CALCULUS

In this section, you shall see some of the mathematical and physical applications of integral calculus. In the mathematical application you calculate the area of a region bounded by curves of continuous functions defined on a closed interval $[a, b]$ and the volume of a solid of revolution.

In the physical applications, you calculate the work done by a variable force along a straight line, acceleration, velocity and displacement.

5.4.1 The Area Between Two Curves

You calculated the area of some regions under the graphs of a non-negative function f on $[a, b]$, when the definite integral $\int_a^b f(x) dx$ was defined. However the focus was to evaluate the integral rather than to calculate area. Here, you use this concept of area in order to determine the area of a region whose upper and lower boundaries are graphs of continuous functions on a given closed interval $[a, b]$.

ACTIVITY 5.9



- 1 Using the definition of the definite integral, calculate the area of the region bounded by the graph of
 - a $y = x$ and the x -axis between $x = 0$ and $x = 1$.
 - b $y = x^2 + 1$ and the x -axis between $x = 0$ and $x = 1$.
- 2 Using the results from **problem 1**, and your knowledge of the area of a shaded part, find the area of the region bounded by the graphs of $f(x) = x^2 + 1$ and $g(x) = x$ between $x = 0$ and $x = 1$.

We extend the problems of the **Activity** to an arbitrary region enclosed by the graphs of continuous functions.

Example 1 Find the area of the region bounded by the graph of the function

$$f(x) = x^2 - 3x + 2 \text{ and the } x\text{-axis between } x = 0 \text{ and } x = 3.$$

Solution Look at the graph of f between $x = 0$ and $x = 3$.

Let A_1 , A_2 and A_3 be the areas of the parts of the region between $x = 0$ and $x = 1$, $x = 1$ and $x = 2$ and $x = 2$ and $x = 3$, respectively.

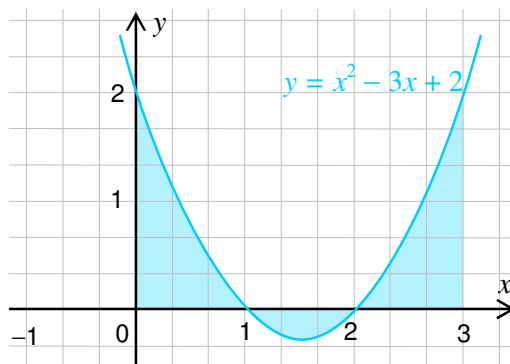

Figure 5.11

The part of the region between $x = 1$ and $x = 2$ is below the x -axis.

$$\Rightarrow A_2 = -\int_1^2 (x^2 - 3x + 2) dx = -\left(\frac{x^3}{3} - \frac{3x^2}{2} + 2x\right)\Bigg|_1^2 = 4 - \frac{23}{6} = \frac{1}{6}$$

Whereas, $A_1 = \int_0^1 (x^2 - 3x + 2) dx = \left(\frac{x^3}{3} - \frac{3x^2}{2} + 2x\right)\Bigg|_0^1 = \frac{5}{6}$ and

$$A_3 = \int_2^3 (x^2 - 3x + 2) dx = \left(\frac{x^3}{3} - \frac{3x^2}{2} + 2x\right)\Bigg|_2^3 = \frac{5}{6}$$

Therefore, the area A of the region is

$$A = A_1 + A_2 + A_3 = \frac{11}{6}$$

What would have happened, if you had simply tried to calculate A as

$$A = \int_0^3 (x^2 - 3x + 2) dx?$$

Example 2 Find the area of the region enclosed by the graph of $f(x) = \sin x$ and the x -axis between $x = -\frac{\pi}{2}$ and $x = 2\pi$.

Solution

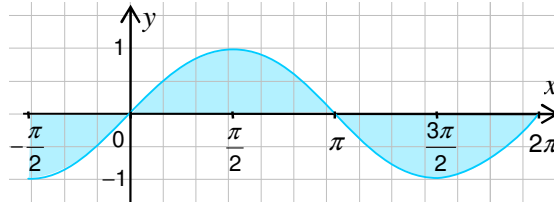

Figure 5.12

From the graph you have the area A of the region

$$\begin{aligned} A &= -\int_{-\pi/2}^0 \sin x \, dx + \int_0^{\pi} \sin x \, dx - \int_{\pi}^{2\pi} \sin x \, dx \\ &= -\cos x \Big|_{-\pi/2}^0 - \cos x \Big|_0^{\pi} + \cos x \Big|_{\pi}^{2\pi} = \cos x \Big|_{-\pi/2}^0 + \cos x \Big|_0^{\pi} + \cos x \Big|_{\pi}^{2\pi} \\ &= \cos 0 + (\cos 0 - \cos \pi) + (\cos (2\pi) - \cos (\pi)) \\ &= 1 + 1 - (-1) + 1 - (-1) = 5 \end{aligned}$$

Example 3 Find the area of the region bounded by the graph of $f(x) = x^5$ and the x -axis between $x = -1$ and $x = 1$.

Solution

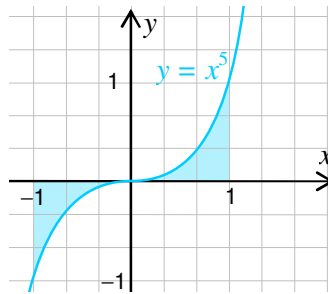

Figure 5.13

From the symmetry of the region, you have the area

$$A = 2 \int_0^1 x^5 \, dx = 2 \left(\frac{x^6}{6} \right) \Big|_0^1 = \frac{1}{3}$$

Example 4 Find the area of the region bounded by the graph of $f(x) = x^3 - 2x^2 + x$ and the x -axis between $x = -1$ and $x = 2$.

Solution

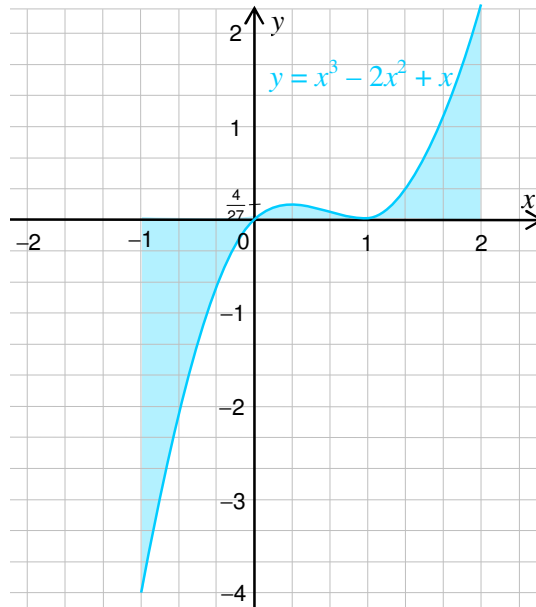

Figure 5.14

$$f(x) = x^3 - 2x^2 + x = x(x^2 - 2x + 1) = x(x - 1)^2$$

Let the area of the part of the region under the x -axis be A_1 .

$$\begin{aligned} \text{Then, } A_1 &= -\int_{-1}^0 (x^3 - 2x^2 + x) dx = -\left(\frac{x^4}{4} - \frac{2x^3}{3} + \frac{x^2}{2}\right)\Bigg|_{-1}^0 \\ &= -\left[0 - \left(\frac{1}{4} + \frac{2}{3} + \frac{1}{2}\right)\right] = \frac{17}{12} \text{ square units} \end{aligned}$$

Let the area of the region above the x -axis be A_2 , then

$$A_2 = \int_0^2 (x^3 - 2x^2 + x) dx = \left(\frac{x^4}{4} - \frac{2x^3}{3} + \frac{x^2}{2}\right)\Bigg|_0^2 = \left(\frac{16}{4} - \frac{16}{3} + 2\right) = \frac{2}{3}$$

\Rightarrow The area A of the region is

$$A = A_1 + A_2 = \frac{17}{12} + \frac{2}{3} = \frac{25}{12}$$

Example 5 Let $f(x) = \begin{cases} 2^x, & \text{if } x \leq 1; \\ 1 + \frac{1}{x}, & \text{if } x > 1. \end{cases}$

Find the area of the region enclosed by the graph of f and the x -axis between $x = -1$ and $x = 2$.

Solution You first show that the function is continuous on $[-1, 2]$.

Look at the graph of f on $[-1, 2]$. The function is continuous on $[-1, 2]$.

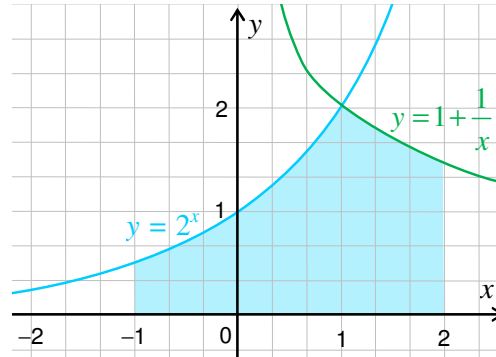

Figure 5.15

The upper part of the region is bounded by the graphs of two functions, $y = 2^x$ and $y = 1 + \frac{1}{x}$ intersecting at $x = 1$.

Let A_1 be the area of the region between the lines $x = -1$ and $x = 1$ and A_2 be the area of the region between the lines $x = 1$ and $x = 2$.

$$\text{Then, } A_1 = \int_{-1}^1 2^x dx = \frac{2^x}{\ln 2} \Big|_{-1}^1 = \frac{1}{\ln 2} \left(2 - \frac{1}{2} \right) = \frac{3}{2 \ln 2} = \frac{3}{2 \ln 2} = \frac{3}{\ln 4}$$

$$A_2 = \int_1^2 \left(1 + \frac{1}{x} \right) dx = x + \ln|x| \Big|_1^2 = 2 + \ln 2 - (1 + \ln 1) = 1 + \ln 2$$

$$\Rightarrow \text{The area of the region } A = A_1 + A_2 = \frac{3}{\ln 4} + 1 + \ln 2.$$

ACTIVITY 5.10

- 1** Using your knowledge of shaded area, determine the area of the region enclosed by the graphs of $f(x) = x^2 + 4$ and $g(x) = 1$ and the lines $x = 1$ and $x = 3$

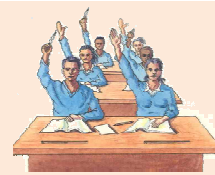

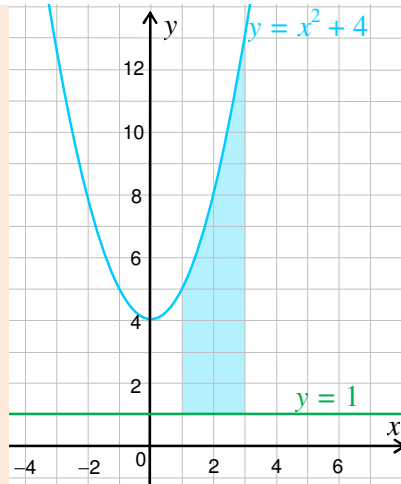

Figure 5.16

2 Consider the following region

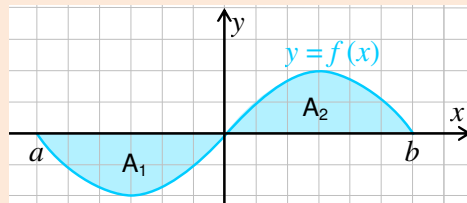

Figure 5.17

Express the area A of the region in terms of the integral of the boundaries $y = f(x)$ and $y = 0$.

Theorem 5.5

Suppose f and g are continuous functions on $[a, b]$ with $f(x) \geq g(x)$ on $[a, b]$. The area A bounded by the curves of $y = f(x)$ and $y = g(x)$ between the lines $x = a$ and $x = b$ is

$$A = \int_a^b (f(x) - g(x)) dx.$$

Example 6 Find the area of the region enclosed by the curves $g(x) = x^2 - x - 6$ and $f(x) = x - 3$.

Solution The first step is to draw the graphs of both functions using the same axes.

You solve the equation $f(x) = g(x)$ to get the intersection points of the graphs.

$$x^2 - x - 6 = x - 3$$

$$\Rightarrow x^2 - 2x - 3 = 0 \Rightarrow (x - 3)(x + 1) = 0 \Rightarrow x = 3 \text{ or } x = -1$$

$$f(x) \geq g(x) \text{ on } [-1, 3]$$

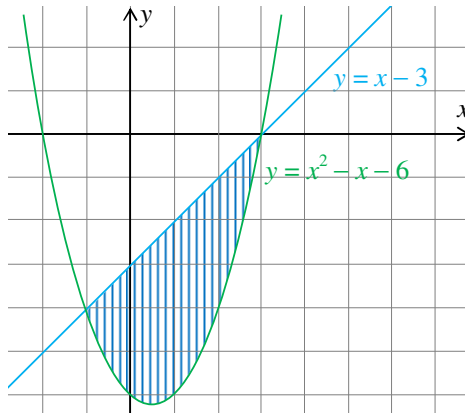

Figure 5.18

 **Note:**

The height of each infinitesimal rectangle within the shaded region is equal to $(f(x) - g(x))$.

⇒ The area of the region is

$$\begin{aligned}
 A &= \int_{-1}^3 ((x-3) - (x^2 - x - 6)) dx = \int_{-1}^3 (-x^2 + 2x + 3) dx = -\frac{x^3}{3} + x^2 + 3x \Big|_{-1}^3 \\
 &= \frac{-27}{3} + 9 + 9 - \left(-\left(\frac{-1}{3}\right) + 1 + 3(-1) \right) = 9 - \left(\frac{1}{3} + 1 - 3 \right) = \frac{32}{3}
 \end{aligned}$$

Example 7 Find the area of the region enclosed by the graphs of $f(x) = 4 - x^2$ and $g(x) = 6 - x$ between the lines $x = -2$ and $x = 3$.

Solution The first step is to draw the graphs of both functions using the same coordinate axes.

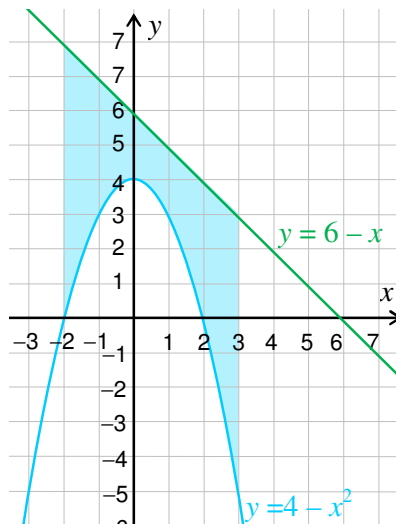

Figure 5.19

$$g(x) \geq f(x) \text{ on } [-2, 3]$$

$$\begin{aligned} \Rightarrow \text{The Area, } A &= \int_{-2}^3 ((6-x) - (4-x^2)) dx = \int_{-2}^3 (x^2 - x + 2) dx \\ &= \left. \frac{x^3}{3} - \frac{x^2}{2} + 2x \right|_{-2}^3 = \frac{27}{3} - \frac{9}{2} + 6 - \left[\frac{-8}{3} - \frac{4}{2} - 4 \right] = \frac{115}{6} \end{aligned}$$

Example 8 Find the area of the region in the first quadrant which is enclosed by the y-axis and the curves of $f(x) = \cos x$ and $g(x) = \sin x$.

Solution Look at the graphs of both functions.

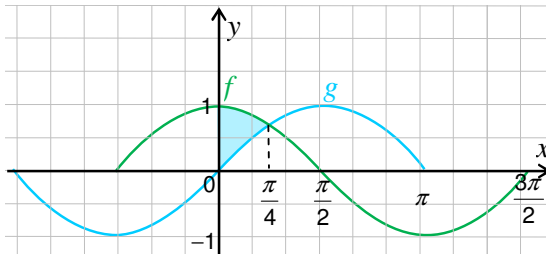

Figure 5.20

The curves meet at $x = \frac{\pi}{4}$ and $\cos x \geq \sin x$ on $\left[0, \frac{\pi}{4}\right]$.

Therefore the required area is

$$\begin{aligned} A &= \int_0^{\frac{\pi}{4}} (\cos x - \sin x) dx = \sin x - (-\cos x) \Big|_0^{\frac{\pi}{4}} \\ &= \sin \frac{\pi}{4} + \cos \frac{\pi}{4} - (\sin 0 + \cos 0) = \frac{\sqrt{2}}{2} + \frac{\sqrt{2}}{2} - 1 = \sqrt{2} - 1 \end{aligned}$$

Example 9 Find the area enclosed by the graphs of $f(x) = x^3 - x$ and $g(x) = x^2 - 1$

Solution The first step is to draw both graphs.

Solve the equation

$x^3 - x = x^2 - 1$ to find out the intersection points of the graphs.

$$x^3 - x = x^2 - 1$$

$$\Rightarrow x^3 - x^2 - x + 1 = 0 \Rightarrow x^2(x-1) - (x-1) = 0 \Rightarrow (x^2-1)(x-1) = 0 \Rightarrow x = \pm 1$$

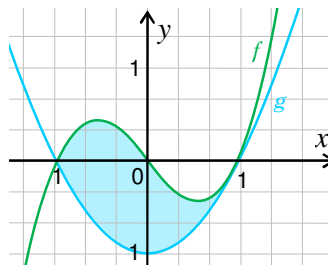

Figure 5.21

The required area is $A = \int_{-1}^1 (x^3 - x - (x^2 - 1)) dx = \int_{-1}^1 (x^3 - x^2 - x + 1) dx$

$$= \left. \frac{x^4}{4} - \frac{x^3}{3} - \frac{x^2}{2} + x \right|_{-1}^1 = \frac{1}{4} - \frac{1}{3} - \frac{1}{2} + 1 - \left(\frac{1}{4} + \frac{1}{3} - \frac{1}{2} - 1 \right) = \frac{4}{3}$$

Example 10 Find the area of the region enclosed by the curves of $f(x) = 2x^2 - x^3$ and $g(x) = 4 - x^2$.

Solution The first step is to determine the intersection points of the graphs and then to draw both graphs.

Thus, $2x^2 - x^3 = 4 - x^2 \Rightarrow x^3 - 3x^2 + 4 = 0$

Using the rational root test, the zeros of $x^3 - 3x^2 + 4$ are $x = -1$ and $x = 2$.

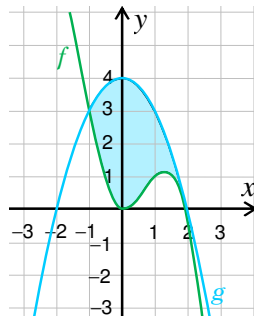

Figure 5.22

The required area is $A = \int_{-1}^2 (4 - x^2) - (2x^2 - x^3) dx = \int_{-1}^2 (x^3 - 3x^2 + 4) dx$

$$= \left. \frac{x^4}{4} - x^3 + 4x \right|_{-1}^2 = \left(\frac{2^4}{4} - 2^3 + 4(2) \right) - \left(\frac{(-1)^4}{4} + 1 - 4 \right)$$

$$= (4 - 8 + 8) - \left(\frac{1}{4} + 1 - 4 \right) = \left(4 + 3 - \frac{1}{4} \right) = \frac{27}{4}$$

Example 11 Find the area enclosed by the graph of $f(x) = |x|$ and the x -axis between the vertical lines $x = -4$ and $x = 3$.

Solution Do you think that $\int_{-4}^3 |x|$ exists? *Explain!*

$f(x) = |x|$ is continuous on $[-4, 3]$.

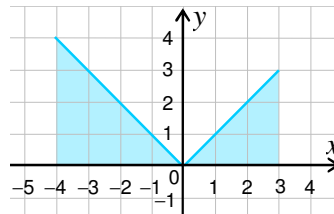

Figure 5.23

You know that $f(x) = \begin{cases} x, & \text{if } x \geq 0 \\ -x, & \text{if } x < 0 \end{cases}$

Thus, the area, $A = \int_{-4}^3 |x| dx = \int_{-4}^0 |x| dx + \int_0^3 |x| dx$

$$= \int_{-4}^0 (-x) dx + \int_0^3 x dx = -\frac{x^2}{2} \Big|_{-4}^0 + \frac{x^2}{2} \Big|_0^3 = -\left(0 - \frac{(-4)^2}{2}\right) + \left(\frac{3^2}{2} - 0\right) = \frac{25}{2}$$

Example 12 Determine the area of the region enclosed by the graphs of $x = -y^2$ and $x = 9 - 2y^2$.

Solution Here the curves are opening in the negative x direction. The region is symmetrical with respect to the x -axis.

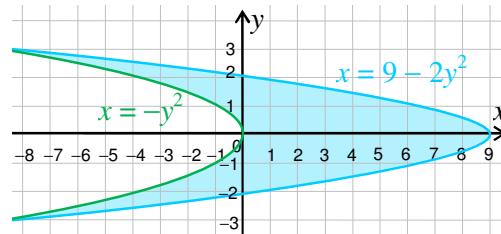

Figure 5.24

You solve $-y^2 = 9 - 2y^2$ in order to determine the intersection points of the graphs.

$$\text{Thus, } -y^2 = 9 - 2y^2 \Rightarrow y^2 = 9 \Rightarrow y = \pm 3$$

The required area is found by integrating with respect to y . [*Can you see why?*]

$$A = 2 \int_0^3 \left((9 - 2y^2) + y^2 \right) dy = 2 \left(9y - \frac{y^3}{3} \right) \Big|_0^3 = 2(27 - 9) = 36$$

Example 13 Find the area of the region enclosed by the graph of $y = x^2 + 1$ and the line $y = 5$.

Solution From the graph, you see that the line $y = 5$ crosses the curve $y = x^2 + 1$ at $x = \pm 2$.

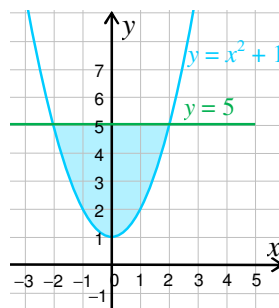

Figure 5.25

$x^2 + 1 \leq 5$ for all $x \in [-2, 2]$. Therefore, the required area is

$$A = \int_{-2}^2 (5 - (x^2 + 1)) dx = 4x - \frac{x^3}{3} \Big|_{-2}^2 = 8 - \frac{8}{3} - \left(-8 + \frac{8}{3}\right) = \frac{32}{3}.$$

Exercise 5.11

- 1** Find the area of the region enclosed by the graphs of the function f and the x -axis from $x = a$ to $x = b$ when
- | | |
|--|---|
| a $f(x) = x$; $x = -3$ and $x = 2$. | b $f(x) = 12 - 3x^2$; $x = -4$ and $x = 3$. |
| c $f(x) = x^3$; $x = -1$ and $x = 1$. | d $f(x) = 2^x$; $x = -1$ and $x = 4$. |
| e $f(x) = \ln x$; $x = \frac{1}{e}$ and $x = e^2$. | f $f(x) = \sin x$; $x = \frac{\pi}{4}$ and $x = \frac{7}{4}\pi$. |
| g $f(x) = \frac{1}{x}$; $x = \frac{1}{10}$ and $x = 1$. | h $f(x) = x^2 + 4$; $x = -1$ and $x = \frac{1}{2}$. |
- 2** Find the area of the region enclosed by the graphs of
- | | |
|--|---|
| a $f(x) = x^2$ and $g(x) = \sqrt{x}$. | b $f(x) = x $ and $g(x) = x^2$. |
| c $f(x) = 3x^2 - 4$ and $g(x) = 2x^2$. | d $f(x) = x^3 - 4x$ and $g(x) = -3x^2$. |

5.4.2 Volume of Revolution



OPENING PROBLEM

A hemispherical bowl of radius 5 m contains some water. If the radius of the surface of the water is 3 m, what is the volume of the water?

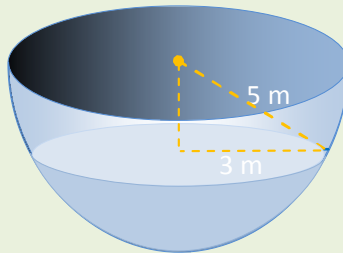

Figure 5.26

In this section, you will apply integral calculus to determine the volume of a solid by considering cross sections. In the study of plants or animals, very thin cross sections are prepared by scientists. During examination in a transmission electron microscope (TEM), the electron beam can penetrate if the sliced specimen is extremely thin, because only the electrons that pass through the specimen are recorded.

Suppose a region rotates about a straight line as shown in Figure 5.27a below. Then a solid figure, called a **solid of revolution**, will be formed [see Figure 5.27b].

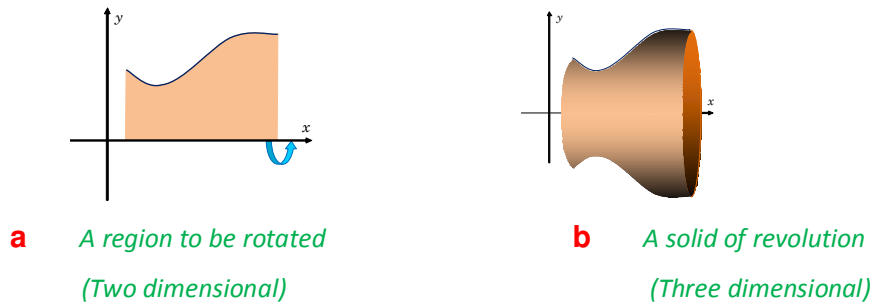

Figure 5.27

ACTIVITY 5.11



Identify the type of the solid so formed when the given region rotates about the x -axis.

- 1 The region bounded by the line $y = 1$ and the x -axis between $x = 0$ and $x = 5$;
- 2 The region bounded by the line $y = x$ and the x -axis between $x = 0$ and $x = 1$;
- 3 The semicircle $x^2 + y^2 = 1$; $0 \leq y \leq 1$ and the x -axis between $x = -1$ and $x = 1$;
- 4 The region between the line $y = x + 1$ and the x -axis between $x = 0$ and $x = 3$;
- 5 The region bounded by $y = \sqrt{4 - x^2}$ and the x -axis between $x = -2$ and $x = -1$.

From the above activity, you have seen different solids formed by rotating an area about a line. In general, a solid of revolution is a three dimensional object formed by rotating an area about a straight line. The next task is to find the volume of such a solid.

The volume of a solid of revolution is said to be a **volume of revolution**. The line about which the area rotates is an **axis of symmetry**.

Now, consider the following solid of revolution generated by revolving the region between the curve $y = f(x)$ and the x -axis from $x = a$ to $x = b$.

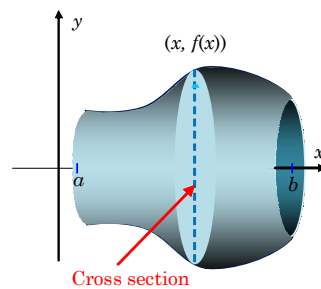

Figure 5.28

Every cross section which is perpendicular to the x -axis at x is a circular region with radius, $r = f(x)$. Thus, the area of the cross section is $\pi r^2 = \pi (f(x))^2$

How to determine the volume of a solid of revolution

Divide the solid of revolution into n equally spaced cross sections which are perpendicular to the axis of rotation [See Figure 5.29].

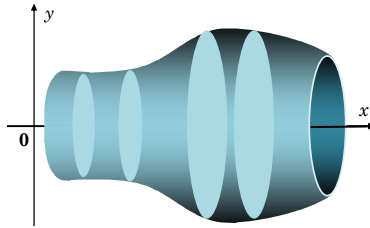

Figure 5.29

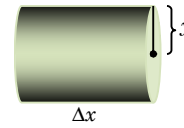

Figure 5.30

As the cuts get close enough, then the sections so obtained will approximately be a cylindrical solid as in Figure 5.30.

Let V_K be the volume of the k^{th} sections, then

$$V_K = \pi r^2 h, \text{ where } r = f(x_k) \text{ and } h = \Delta x$$

$$\Rightarrow V_k = \pi (f(x_k))^2 \Delta x$$

Let ΔV be the sum of the volumes of the n sections.

$$\text{Then, } \Delta V = \sum_{k=1}^n v_k .$$

The volume V of the solid of revolution is

$$V = \lim_{\Delta x \rightarrow 0} \Delta V = \lim_{n \rightarrow \infty} \sum_{k=1}^n V_k = \lim_{n \rightarrow \infty} \sum_{k=1}^n \pi (f(x_k))^2 \Delta x = \int_a^b \pi (f(x))^2 dx$$

Example 14 Find the volume generated when the area bounded by the line $y = x$ and the x -axis from $x = 0$ to $x = 3$ is rotated about the x -axis.

Solution

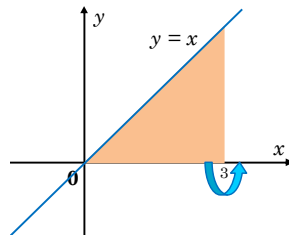

a Rotating the region about the x -axis gives the solid as shown in the figure on the right. Using the definite integral the volume V is determined as follows

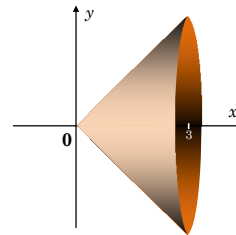

b The solid of revolution is a right circular cone with radius and height each 3 units long.

Figure 5.31

$$V = \pi \int_0^3 x^2 dx = \frac{\pi x^3}{3} \Big|_0^3 = 9\pi$$

Check that you arrive at the same result, if you use $V = \frac{1}{3} \pi r^2 h$ for the volume of the cone.

Example 15 Find the volume of the solid generated by revolving the region bounded by the graph of $y = x^2$ and the x -axis between $x = 0$ and $x = 1$ about the x -axis.

Solution

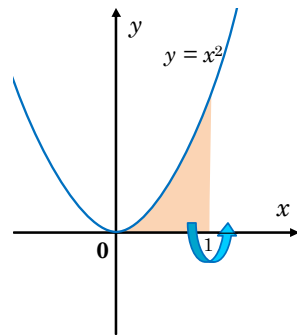

a The region to be rotated

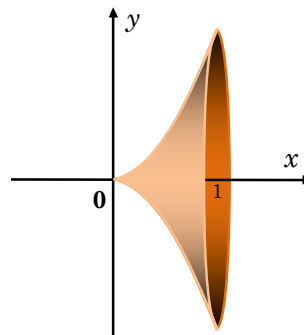

b The solid of revolution

Figure 5.32

$$V = \pi \int_0^1 (x^2)^2 dx = \frac{\pi x^5}{5} \Big|_0^1 = \frac{\pi}{5}$$

Example 16 The area bounded by the graph of $y = x^2 + 1$ and the line $y = 4$ rotates about the y -axis, find the volume of the solid generated.

Solution

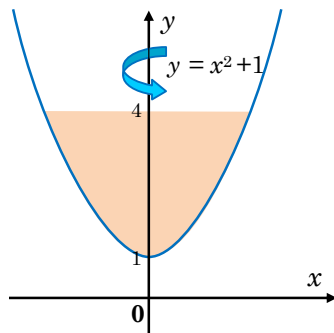

a The region being rotated about the y -axis.

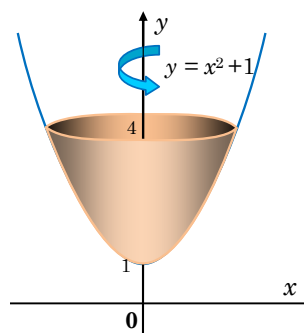

b The solid of revolution

Figure 5.33

$y = x^2 + 1 \Rightarrow x = \pm \sqrt{y-1}$. Here, you have horizontal cross sections.

$$V = \pi \int_1^4 (\sqrt{y-1})^2 dx = \pi \int_1^4 (y-1) dy = \pi \left(\frac{y^2}{2} - y \right) \Big|_1^4 = \pi \left(\frac{16}{2} - 4 \right) - \left(\frac{1}{2} - 1 \right) = \frac{9}{2} \pi$$

Example 17 Find the volume of the solid of revolution about the x -axis, when the region enclosed by $y = e^x - 1$ and the x -axis from $x = \ln\left(\frac{1}{2}\right)$ to $x = \ln(2)$ rotates.

Solution $\ln\left(\frac{1}{2}\right) = -\ln(2)$

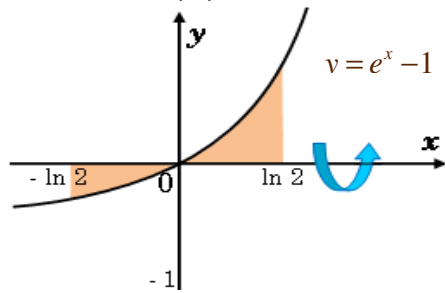

a The region to be rotated

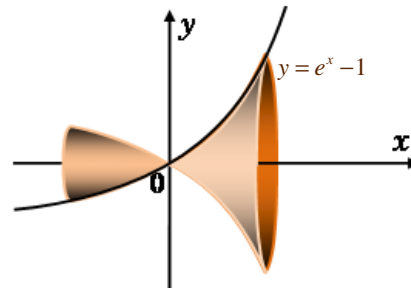

b The solid of revolution

Figure 5.34

$$\begin{aligned}
 V &= \pi \int_{-\ln(2)}^{\ln(2)} (e^x - 1)^2 dx \\
 &= \pi \int_{-\ln(2)}^{\ln(2)} (e^{2x} - 2e^x + 1) dx = \pi \left(\frac{e^{2x}}{2} - 2e^x + x \right) \Big|_{-\ln(2)}^{\ln(2)} \\
 &= \pi \left(\frac{e^{2\ln 2}}{2} - 2e^{\ln 2} + \ln 2 - \left(\frac{e^{-2\ln 2}}{2} - 2e^{-\ln 2} - \ln 2 \right) \right) \\
 &= \pi \left(2 - 4 + \ln 2 - \left(\frac{1}{8} - 1 - \ln 2 \right) \right) \\
 &= \pi \left(-2 + \ln 2 - \left(-\frac{7}{8} - \ln 2 \right) \right) = \pi \left(-2 + 2\ln 2 + \frac{7}{8} \right) = \left(2\ln 2 - \frac{9}{8} \right) \pi
 \end{aligned}$$

Example 18 Using the volume of a solid of revolution, show that the volume of a sphere of radius r is $\frac{4}{3}\pi r^3$.

Solution In **Activity 5.11** you should have seen that a sphere of radius r is generated when the semicircular region $x^2 + y^2 \leq r^2$; $0 \leq y \leq r$ revolves around the x -axis.

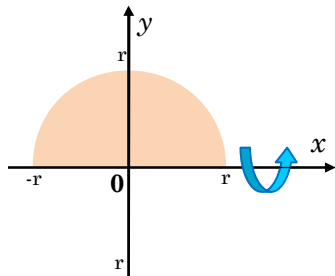

a The semicircular region to be rotated

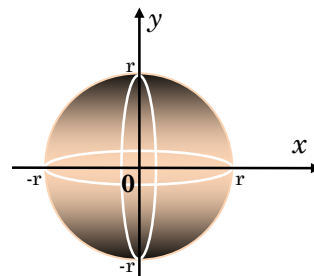

b A sphere of radius r

Figure 5.35

$$x^2 + y^2 = r^2 ; 0 \leq y \leq r \Rightarrow y = \sqrt{r^2 - x^2}$$

The volume

$$\begin{aligned} V &= \pi \int_{-r}^r (\sqrt{r^2 - x^2})^2 dx = \pi \int_{-r}^r (r^2 - x^2) dx = \left(r^2 x - \frac{x^3}{3} \right) \Big|_{-r}^r \\ &= \pi \left(r^2 (r) - \frac{r^3}{3} - \left(r^2 (-r) - \frac{(-r)^3}{3} \right) \right) = \pi \left(r^3 - \frac{r^3}{3} - \left(-r^3 + \frac{r^3}{3} \right) \right) = \frac{4}{3} \pi r^3 \end{aligned}$$

Example 19 Find the volume of water in a spherical bowl of radius 5 m, if its maximum depth is 2 m.

Solution From Figure 5.36, you can determine the radius of the surface of the water which is 4 m.

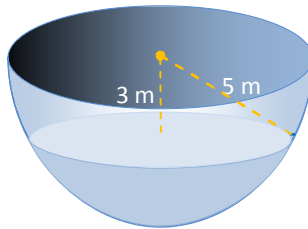

Figure 5.36

The hemisphere can be generated by the quarter of the circular region.

$x^2 + y^2 = 25 ; 0 \leq x \leq 5$ and $-5 \leq y \leq 0$ revolving about the y-axis.

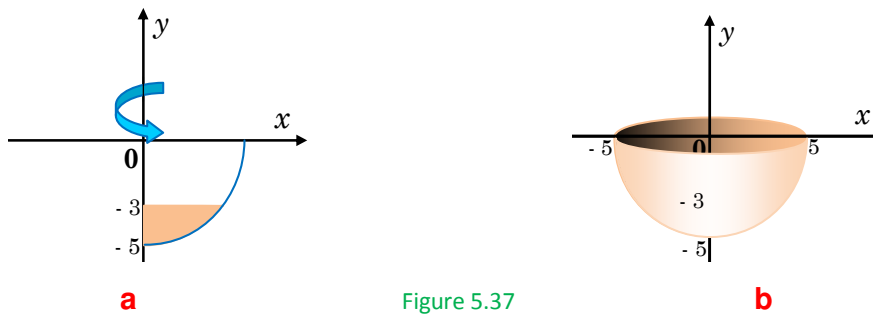
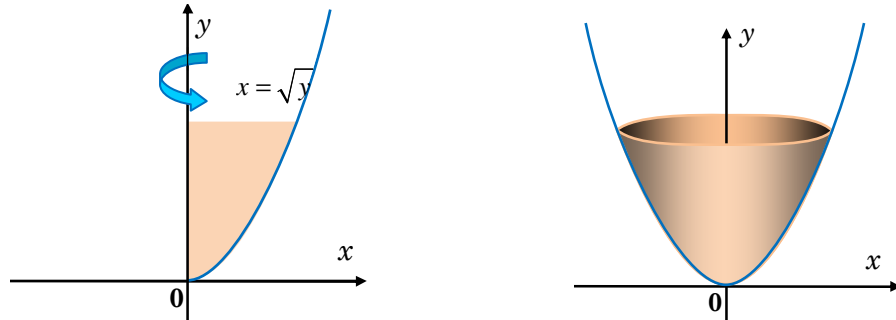

Figure 5.37

$$\begin{aligned} \text{The volume of the water} &= \pi \int_{-5}^{-3} (\sqrt{25 - y^2})^2 dy = \pi \int_{-5}^{-3} (25 - y^2) dy \\ &= \pi \left(25y - \frac{y^3}{3} \right) \Big|_{-5}^{-3} = \pi \left(25(-3) - \left(\frac{-27}{3} \right) - \left(-125 + \frac{125}{3} \right) \right) \\ &= \frac{52}{3} \pi \text{ cm}^3. \end{aligned}$$

Example 20 Find the volume of the solid of revolution about the y -axis generated by revolving the region enclosed by the curve $x = \sqrt{y}$ and the y -axis from $y = 0$ to $y = 4$.

Solution
$$V = \pi \int_0^4 (\sqrt{y})^2 dy = \pi \int_0^4 y dy = \pi \left(\frac{y^2}{2} \right) \Big|_0^4 = 8\pi$$



a The region to rotated about the y -axis **b** The solid of revolution
Figure 5.38

Example 21 If the region bounded by the curve $y = x^2$ and the line $y = 4$ rotates about the x -axis, find the volume of the solid of revolution.

Solution The first step is to determine the intersection points of the line and the curve and then sketch both graphs together.

$$x^2 = 4 \Rightarrow x = \pm 2$$

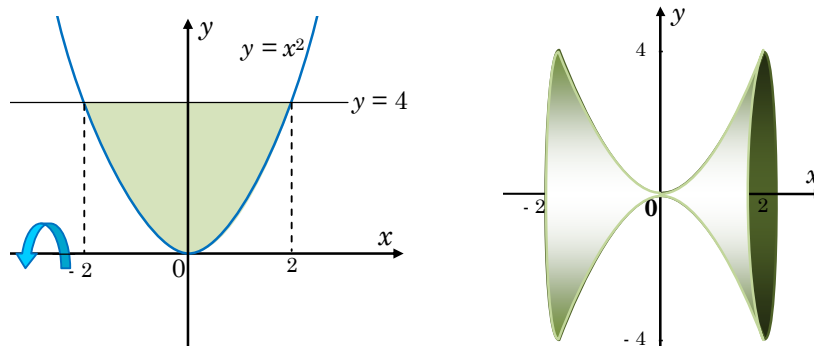

a The region to be rotated about the x -axis **b** The solid of revolution

Figure 5.39

The solid of revolution is a cylinder that has a vacant space generated by the area bounded by $y = x^2$ and the x -axis from $x = -2$ to $x = 2$.

Let V_1 be the volume of vacant space.

$$\text{Then } V_1 = \pi \int_{-2}^2 (x^2)^2 dx = \frac{\pi x^5}{5} \Big|_{-2}^2 = \pi \left(\frac{32}{5} - \left(-\frac{32}{5} \right) \right) = \frac{64}{5} \pi$$

Let V_2 be the volume of the cylinder, then

$$V_2 = \pi \int_{-2}^2 4^2 dx = 16\pi x \Big|_{-2}^2 = 16\pi(2 - (-2)) = 64\pi$$

Thus, the volume V of the required solid is

$$V = V_2 - V_1 = 64\pi - \frac{64\pi}{5} = \frac{256\pi}{5}$$

Observe that

$$\begin{aligned} V &= V_2 - V_1 = \pi \int_{-2}^2 4^2 dx - \pi \int_{-2}^2 (x^2)^2 dx = \pi \int_{-2}^2 (4^2 - (x^2)^2) dx \\ &= \pi \int_{-2}^2 (4^2 - x^4) dx = \pi \int_{-2}^2 (16 - x^4) dx = \pi \int_{-2}^2 16 dx - \pi \int_{-2}^2 x^4 dx \\ &= \pi \times 16x \Big|_{-2}^2 - \pi \frac{x^5}{5} \Big|_{-2}^2 = \pi(32 + 32) - \pi \left(\frac{32}{5} + \frac{32}{5} \right) \\ &= 64\pi - \frac{64}{5} \pi = \frac{256\pi}{5} \end{aligned}$$

From the above observation, can you see how to calculate the volume of a solid of revolution generated by an area enclosed by two curves?

Consider the region enclosed by the curves $y = f(x)$ and $y = g(x)$ between $x = a$ and $x = b$.

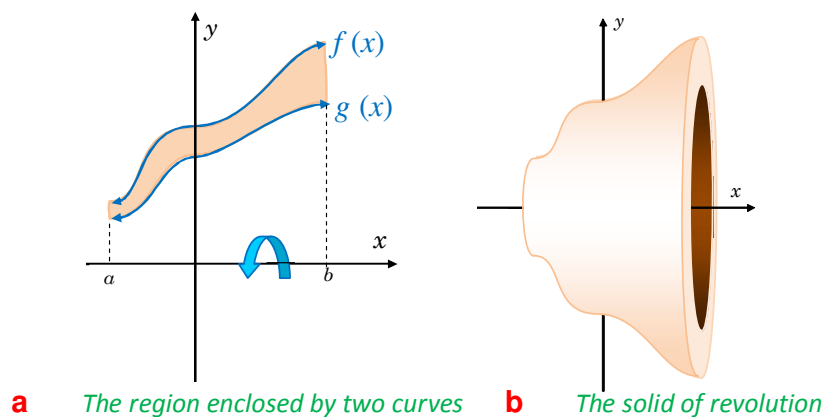

Figure 5.40

Using the concept seen in [Example 21](#), you have the volume V of the solid of revolution to be

$$V = \pi \int_a^b \left((f(x))^2 - (g(x))^2 \right) dx$$

Example 24 *Work done by a variable force*

The work done by a force F through a displacement from x_1 to x_2 is

$$\int_{x_1}^{x_2} |F| dx$$

Find the work done when a particle is moved through a displacement of 10m along a smooth horizontal surface by a force F of magnitude $\left(9 - \frac{1}{2}x\right)$ N.

Where x is the displacement of the particle from its initial position, in metres.

Solution

$$\text{Work done} = \int_0^{10} |F| dx = \int_0^{10} \left(9 - \frac{1}{2}x\right) dx = 9x - \frac{x^2}{4} \Big|_0^{10} = 90 - \frac{100}{4} = 65.$$

Motion of a particle in a straight line

Suppose a particle P moves along a straight line \overline{OX} with O as its initial point.

The velocity v is the rate at which the displacement s increases with respect to time t .

$$\Rightarrow v = \frac{ds}{dt} \Rightarrow \int v dt = \int ds \quad \Rightarrow s = \int v dt$$

The acceleration a is the rate at which the velocity increases with respect to time t .

$$\Rightarrow a = \frac{dv}{dt} \Rightarrow \int a dt = \int dv \Rightarrow v = \int a dt$$

Example 25 Suppose a particle P moves along a straight line \overline{OX} with an acceleration of $3.5t$. When $t = 2$ sec, P has a displacement of 10 m from O and a velocity of 15 m/sec. Find the velocity v and the displacement when $t = 5$ sec.

Solution Using the given information you have,

$$v = \int a dt = \int 3.5t dt = \frac{3.5}{2}t^2 + c. \text{ But } v(2) = 15 \Rightarrow 15 = \frac{3.5}{2}(2)^2 + c \Rightarrow c = 8.$$

$$v = \frac{7}{4}t^2 + 8.$$

$$\text{Also, } s = \int v dt \Rightarrow s = \int \left(\frac{7}{4}t^2 + 8\right) dt = \frac{7}{12}t^3 + 8t + c$$

$$\text{But } s(2) = 10 \Rightarrow 10 = \frac{7}{12}(2)^3 + 8(2) + c$$

$$\Rightarrow c = -\frac{32}{3} \Rightarrow s = \frac{7}{12}t^3 + 8t - \frac{32}{3}$$

Therefore, when $t = 5$,

a the velocity, $v = \frac{7}{4}(5)^2 + 8 = 51.75$ m/sec

b the displacement, $s = \frac{7}{12}(5)^3 + 8(5) - \frac{32}{3} = 102.25$ m

Exercise 5.12

- 1** Find the volume of the solid of revolution about the x -axis generated by revolving the region enclosed by the given function, the x -axis and the vertical lines.
- a** $y = 2x$; $x = 0$ and $x = 1$ **b** $y = x^2 + 1$; $x = -1$ and $x = 2$
- c** $y = e^x$; $x = 1$ and $x = 2$ **d** $y = \sin x$; $x = \frac{\pi}{3}$ and $x = \frac{\pi}{2}$
- e** $y = |x|$; $x = -3$ and $x = 1$ **f** $y = 2^x$; $x = -2$ and $x = 3$
- g** $y = x^3$; $x = -1$ and $x = 2$
- 2** Find the volume of the solid of revolution about the x -axis generated by revolving the region enclosed by the graphs of the given functions.
- a** $f(x) = 4x - x^2$ and $g(x) = 3$
- b** $f(x) = x^3$ and $g(x) = x$
- c** $f(x) = \sin x$ and $g(x) = \cos x$ from $x = 0$ to $x = \frac{\pi}{2}$
- d** $f(x) = x^2$, $g(x) = |x|$ from $x = -2$ to $x = 2$
- 3** Using the volume of revolution, prove that the volume of a frustum of a right circular cone of radii R and r and height h is $\frac{\pi}{3}h(R^2 + rR + r^2)$.
- 4** A particle P starts from a point A with velocity 4 m/sec. If it is moving along a straight line AB with an acceleration of $-1.5t^2$ at a time t seconds, find
- a** the acceleration **b** the velocity and
- c** the displacement after ten seconds



Key Terms

acceleration	differentiation	partial fraction
anti derivative	displacement	substitution
area	fundamental theorem	velocity
by parts	indefinite integral	volume of revolution
definite integral	integration	work done by force



Summary

1 Anti derivative or Indefinite integral

Let $f(x)$ be a function, then

- ✓ $F(x)$ is said to be an antiderivative of $f(x)$ if $F'(x) = f(x)$.
- ✓ The set of antiderivatives of $f(x)$ is said to be the indefinite integral of $f(x)$.
- ✓ The indefinite integral of $f(x)$ is denoted by $\int f(x) dx$
- ✓ If $F(x)$ and $G(x)$ are anti derivatives of $f(x)$, then the difference between $F(x)$ and $G(x)$ is a constant.

2 The Integral of Some Functions

The Integral of power functions

- i $\int x^r dx = \frac{x^{r+1}}{r+1} + c; r \neq -1.$
- ii If $r = -1$, then $\int \frac{1}{x} dx = \ln|x| + c.$
- iii $\int kx^r dx = k \int x^r dx$

The Integral of trigonometric functions

- i $\int \cos x dx = \sin x + c$
- ii $\int \sin x dx = -\cos x + c$
- iii $\int \sec^2 x dx = \tan x + c$
- iv $\int \sec x \tan x dx = \sec x + c$
- v $\int \tan x dx = -\ln|\cos x| + c$
- vi $\int \csc x \cot x dx = -\csc x + c$
- vii $\int \csc^2 x dx = -\cot x + c$

The Integral of exponential functions

- i $\int e^x dx = e^x + c$
- ii $\int a^x dx = \frac{a^x}{\ln a} + c; a > 0 \text{ and } a \neq 1$

The integral of logarithmic functions

- i $\int \ln x dx = x \ln x - x + c$
- ii $\int \log_a x dx = \frac{1}{\ln a} (x \ln x - x) + c$

3 The Integral of a sum or difference of functions

- i $\int kf(x) dx = k \int f(x) dx$
- ii $\int (f(x) \pm g(x)) dx = \int f(x) dx \pm \int g(x) dx$

4 Techniques of Integration**Integration by substitution**

$$\int f(g(x)) \cdot g'(x) dx = \int f(u) du; \text{ where } u = g(x).$$

$$\text{i} \quad \int f'(x)f(x)dx = \frac{(f(x))^2}{2} + c \quad \text{ii} \quad \int \frac{f'(x)}{f(x)}dx = \ln|f(x)| + c$$

Integration by parts

$$\int u \frac{dv}{dx} = uv - \int v \frac{du}{dx}$$

5 Fundamental Theorem of Calculus

$$\text{If } f(x) = F'(x), \text{ then } \int_a^b f(x) dx = F(b) - F(a)$$

6 Properties of definite integrals

$$\text{i} \quad \int_a^b k f(x) dx = k \int_a^b f(x) dx$$

$$\text{ii} \quad \int_a^b (f(x) \pm g(x)) dx = \int_a^b f(x) dx \pm \int_a^b g(x) dx$$

$$\text{iii} \quad \text{If } f(x) \geq 0 \text{ on } [a, b], \text{ then } \int_a^b f(x) dx \geq 0$$

$$\text{iv} \quad \int_a^b f(x) dx = -\int_b^a f(x) dx$$

$$\text{v} \quad \int_a^a f(x) dx = 0$$

$$\text{vi} \quad \int_a^b f(x) dx = \int_a^c f(x) dx + \int_c^b f(x) dx; a \leq c < b.$$

$$\text{vii} \quad \text{If } u = g(x), \int_a^b f(g(x)) \cdot g'(x) dx = \int_{g(a)}^{g(b)} f(u) du$$

7 Applications of the definite integral

- i** The area A bounded by two continuous curves $y = f(x)$ and $y = g(x)$ on $[a, b]$ with $f(x) \geq g(x) \forall x \in [a, b]$ is

$$A = \int_a^b (f(x) - g(x)) dx.$$

- ii** The volume V of a solid of revolution generated by revolving the region bounded by $y = f(x)$ and $y = g(x)$ with $f(x) \geq g(x) \forall x \in [a, b]$ about the x -axis is

$$V = \pi \int_a^b ((f(x))^2 - (g(x))^2) dx.$$



Review Exercises on Unit 5

In exercises 1 – 60, integrate the expression with respect to x .

1 $\frac{1}{2}x$	2 $2x + 5$	3 $x^2 - 3x + 2$	4 $3x^5$
5 x^7	6 $x^{\frac{3}{2}}$	7 $x^{\frac{1}{3}}$	8 $x^{\frac{1}{3}} + x\sqrt{x} - \frac{1}{2x} + x$
9 $2x^{-3}$	10 $x^{\frac{2}{5}}$	11 $\sin(x + 2)$	12 $4^x - \sin x$
13 $\tan(3x - 4)$	14 $x(x^2 + 1)$	15 $\sqrt{2x + 7}$	16 $(3x + 5)^{13}$
17 $(x^2 - 1)^3$	18 $\frac{(x + 1)(x^2 + 2x + 5)^{10}}{2x + 5}$	19 $\frac{x}{x + 1}$	20 $\frac{1}{x^2 - 16}$
21 $x\sqrt{(x^2 + 4)^5}$	22 $\frac{x}{x^2 - 2x - 3}$	23 $2^{4x + 3}$	24 $x \log \sqrt{x^2 + 1}$
25 $\sin^{(n)}(x) \cos x$	26 $\frac{3^{x+1}}{5^{1-4x}}$	27 $\frac{\ln x}{x}$	28 $x \sin(3x^2)$
29 $x x $	30 $\sqrt{6 + x}$	31 $\frac{\sqrt{x} + x}{x\sqrt[3]{x}}$	32 $(1 + 2^x)^2$
33 $\frac{2\sqrt{x}}{\sqrt{x}}$	34 $\frac{2x + 1}{4^{x^2 + x + 1}}$	35 $2^x 2x\sqrt{1 + 2^x}$	36 $\frac{(e^{x+3})(3^{x+5})}{2^{3x-2}}$
37 $\frac{\cos x}{3 + \sin x}$	38 $\frac{1}{x^2} \cos\left(\frac{1}{x}\right)$	39 $\frac{\sec^2 \sqrt{x}}{\sqrt{x}}$	40 $\frac{\sin x}{\cos^7 x}$
41 xe^{x^2}	42 $x^{-2}e^{\frac{1}{x}}$	43 $\frac{e^x}{x^2}$	44 $\frac{x + 1}{x^2 + 2x + 4}$
45 $\frac{4}{(x + 3)^2}$	46 $\frac{x^2}{x + 3}$	47 $\frac{(2x + 1)(x^2 + x + 3)^{10}}{+ 3}$	48 $x\sqrt{9 + x^3}$
49 $\cos x e^{\sin x}$	50 $\frac{x}{\sqrt{x^2 + 5x}}$	51 $(1 + 2e^x)^2$	52 $\sin^3\left(\frac{x}{3}\right)$
53 $\frac{3x}{x^2 - 1}$	54 $\frac{3x^2}{x^2 - 9}$	55 $\frac{x}{(x - 2)(x + 1)^2}$	56 $\frac{3x + 2}{(x + 3)^2}$
57 $\frac{4}{x^2(x + 1)^2}$	58 $\frac{2x^2 + 1}{(x + 1)^2(x + 3)}$	59 $\frac{x^3 + 1}{x^2(x - 4)}$	60 $\frac{x}{(x^2 - 1)(x + 3)}$

In exercises 61 – 85 evaluate the definite integral.

61	$\int_a^b dx$	62	$\int_{e-1}^{e+1} 4dx$	63	$\int_2^3 (x-5) dx$
64	$\int_1^2 6x^3 dx$	65	$\int_0^1 e^x dx$	66	$\int_1^4 \sqrt{x} dx$
67	$\int_{\sqrt{2}}^3 3^x dx$	68	$\int_1^8 x^{\frac{1}{3}} dx$	69	$\int_1^3 \sqrt{x} \left(1 - \frac{1}{x}\right) dx$
70	$\int_{-1}^1 e^{x+3} dx$	71	$\int_0^1 3^{2x+5} dx$	72	$\int_{\frac{1}{2}}^1 2^{3x-2} dx$
73	$\int_0^1 \frac{1}{x+1} dx$	74	$\int_{-2}^2 (e^x + e^{-x}) dx$	75	$\int_{\frac{1}{n}}^1 e^{nx} dx$
76	$\int_2^3 \frac{x}{x+5} dx$	77	$\int_0^3 x\sqrt{x^2+1} dx$	78	$\int_1^9 \frac{e^{\sqrt{x}}}{\sqrt{x}} dx$
79	$\int_{\frac{\pi}{2}}^{\pi} \cos(5x) dx$	80	$\int_{\frac{\pi}{2}}^{\pi} \sin x \cos^2 x dx$	81	$\int_0^1 \frac{t}{4^{t^2-1}} dt$
82	$\int_0^{\pi} \frac{\sin x}{4 + \cos x} dx$	83	$\int_{-2}^1 (x+1)\sqrt{x+2} dx$	84	$\int_1^0 x(8x^2 - 1)^6 dx$
85	$\int_1^2 \frac{2x-3}{(x^2-3x+1)} dx$				

In exercises 86 – 97 find the area of the region bounded by the graph of f , the x -axis and the lines $x = a$ and $x = b$.

86	$f(x) = 4; a = -1, b = 2$	87	$f(x) = 3x; a = -3, b = -1$
88	$f(x) = 3x + 1; a = 0, b = 3$	89	$f(x) = 2x^2 + 1; a = 0, b = 3$
90	$f(x) = 1 - 4x^2; a = -1, b = 1$	91	$f(x) = x^3; a = -\frac{1}{2}, b = 2$
92	$f(x) = e^x; a = -1, b = 4$	93	$f(x) = \frac{x}{x+1}; a = -\frac{1}{2}, b = 3$
94	$f(x) = \sqrt{x} + \frac{1}{\sqrt{x}}; a = \frac{1}{4}, b = 4$	95	$f(x) = \ln x; a = \frac{1}{e}, b = e$
96	$f(x) = x^3 - 2x^2 - 5x + 6; a = -2, b = 3$	97	$f(x) = x^2 - 1 ; a = -3, b = 2$

98 Find each of the following shaded areas.

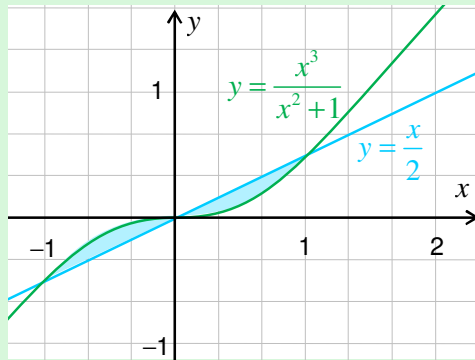

a

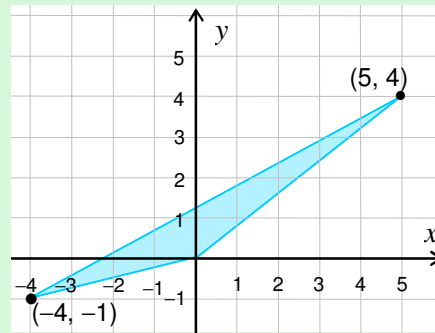

b

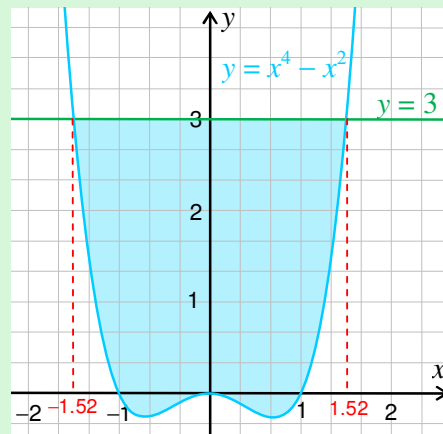

c

Figure 5.43

99 Find the area of the region enclosed by

a $f(x) = x$, $y = \frac{1}{x}$ and $y = 4$

b $f(x) = 4 - x^2$ and $g(x) = 3x$.

100 Find the volume of the solid generated when the region enclosed by the x -axis and the given curves and lines is rotated about the x -axis.

a $y = 4x - x^2$

b $y = x^3 + 1$; $x = -1$, $x = 2$

101 Find the volume of the solid generated when the region bounded by $y = 3x$ and $y = x^2 + 2$ rotates about the x -axis.

102 Find the volume of the solid of revolution generated when the region enclosed by the curve $y = e^x$, the y -axis and the line $y = e$ rotates about the y -axis.

Unit 6

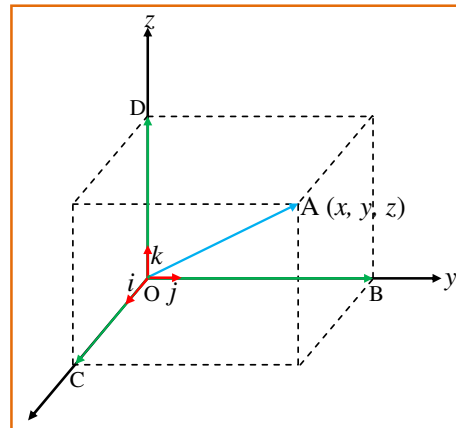

THREE DIMENSIONAL GEOMETRY AND VECTORS IN SPACE

Unit Outcomes:

After completing this unit, you should be able to:

- know methods and procedures for setting up coordinate systems in space.
- know basic facts about coordinates and their use in determining geometric concepts in space.
- apply facts and principles about coordinates in space to solve related problems.
- know specific facts about vectors in space.

Main Contents

6.1 COORDINATE AXES AND COORDINATE PLANES IN SPACE

6.2 COORDINATES OF A POINT IN SPACE

6.3 DISTANCE BETWEEN TWO POINTS IN SPACE

6.4 MIDPOINT OF A LINE SEGMENT IN SPACE

6.5 EQUATION OF SPHERE

6.6 VECTORS IN SPACE

Key terms

Summary

Review Exercises

INTRODUCTION

In this unit, you will be introduced to the coordinate system in space which is an extension of the coordinate system on the plane that you are already familiar with. Thus, the unit begins with a short revision of the coordinate plane and then introduces the **three dimensional coordinate system**. You will learn how the three dimensional coordinates are used to find distance between two points, the midpoint of a line segment in space and also how they are used to derive the equation of a sphere. Finally, you will see how three dimensional coordinates can be applied to the study of vectors in space.

Each topic in this unit is preceded by a few activities and you are expected to attempt every activity. Attempting all the exercises at the end of each section will also help you progress with confidence.



OPENING PROBLEM

Two airplanes took off from the same airport at the same time. One was heading north with a ground speed of 600km/hr and the second heading east with a ground speed of 700km/hr. If the flight level of the one heading north is 10km and that of heading east is 12km, what is the direct distance between the two airplanes exactly one hour after takeoff?

6.1 COORDINATE AXES AND COORDINATE PLANES IN SPACE

Recall that you set up a rectangular coordinate system on a plane by using two straight lines that are perpendicular to each other at a point O . One of the lines, called the x -axis, is made horizontal and the second line, called the y -axis is made vertical. Then using these two axes you associate each point P of the plane with a unique ordered pair of real numbers written as (x, y) .

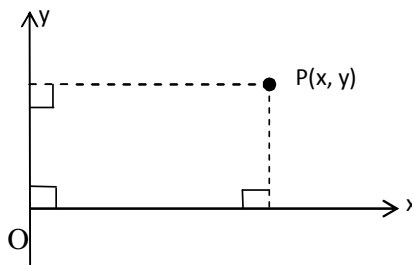

Figure 6.1

ACTIVITY 6.1



- 1** Plot each of the following points on the xy -coordinate plane.
- | | | | | | |
|----------|-------------|----------|---|----------|---|
| a | $P(2, 3)$ | b | $Q(-3, 3)$ | c | $R(0, -4)$ |
| d | $S(-2, -3)$ | e | $T\left(-\frac{3}{4}, \frac{1}{2}\right)$ | f | $U\left(\frac{3}{2}, -\frac{5}{2}\right)$ |
- 2** By naming the vertical axis on the plane z , and the horizontal axis y , plot the following points.
- | | | | | | |
|----------|-----------|----------|------------|----------|-------------|
| a | $A(2, 4)$ | b | $B(-2, 3)$ | c | $C(-3, -4)$ |
|----------|-----------|----------|------------|----------|-------------|

This association of the points of the plane and ordered pairs of real numbers is a one-to-one correspondence.

The rectangular coordinate system is extended to three dimensional spaces as follows. Consider a fixed point O in space and three lines that are mutually perpendicular at the point O . The point O is called the origin; the three lines are now called the x -axis, the y -axis and the z -axis. It is common to have the x and the y -axes on a horizontal plane and the z -axis vertical or perpendicular to the plane containing the x and the y -axes at the point O as shown in Figure 6.2a below. The directions of the axes are based on the right hand rule shown in Figure 6.2b below.

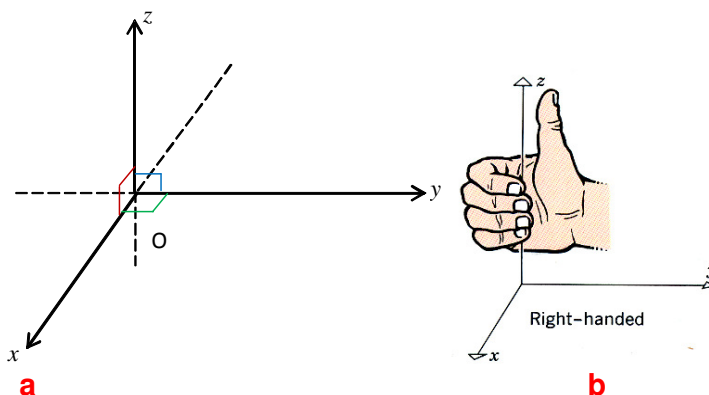

Figure 6.2

The plane determined by the x and the y -axes is called the xy -plane, the plane determined by the x and the z -axes is called the xz -plane and the plane determined by the y and the z -axes is called the yz -plane. These three **coordinate planes**, which intersect at the origin, may be visualized as the floor of a room and two adjacent walls of that room, where the floor represents the xy -plane, the two walls corresponding to xz and yz -planes that intersect on the z -axis and the corner of the room corresponding to the origin.

Commonly, the positive direction of the x -axis is coming out of the page towards the reader; the positive y direction is to the right and the positive z direction is upwards. (Opposite directions to these are negative).

Notice that the **coordinate planes** partition the space into eight parts known as **octants**. Octant 1 is the part of the space whose bounding edges are the three positive axes, namely, the positive x -axis, the positive y -axis and the positive z -axis. Then octants 2, 3 and 4 are those which lie above the xy -plane in the counter clockwise order about the z -axis. Octants 5, 6, 7 and 8 are those which lie below the xy -plane, where octant 5 is just below octant 1 and the rest being in the counter clockwise order about the z -axis again.

6.2 COORDINATES OF A POINT IN SPACE

As indicated at the beginning of this unit, a point P on a plane is associated with a unique ordered pair of real numbers (x, y) using two perpendicular lines known as the x -axis and the y -axis. You also remember that x represents the directed distance of P from the y -axis and y represents the directed distance of P from the x -axis. For example, if the coordinates of P are $(-3, 2)$, it means that P is 3 units to the **left** of the y -axis and 2 units **above** the x -axis. Similarly, a point $Q(4, -5)$ is found 4 units to the **right** of the y -axis and 5 units **below** the x -axis.

ACTIVITY 6.2



Plot each of the following points using the three axes introduced above.

- a** $A(3,4,0)$ **b** $B(0,3,4)$ **c** $C(3,0,4)$

Now a point P in space is located by specifying its directed distances from the three coordinate planes. Its directed distance from the yz -plane measured along or parallel to the x -axis is its x -coordinate. Its directed distance from the xz -plane measured along or in the direction of the y -axis is its y -coordinate and its directed distance measured along or in the direction of the z -axis from the xy -plane is its z -coordinate.

The coordinates of P are therefore written as **an ordered triple** (x, y, z) as shown in **Figure 6.3** below.

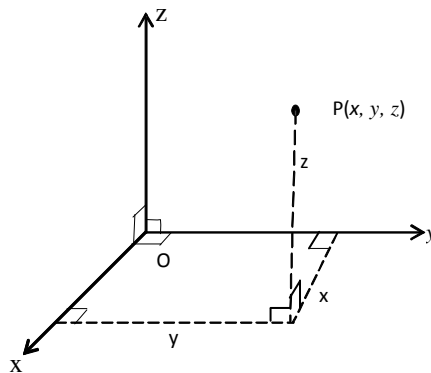

Figure 6.3

Example 1 Locate the point $A(2, 4, 3)$ in space using the reference axes x , y and z .

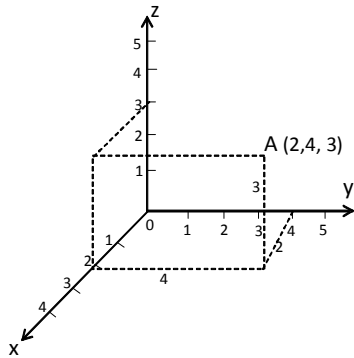

Figure 6.4 (Example 1)

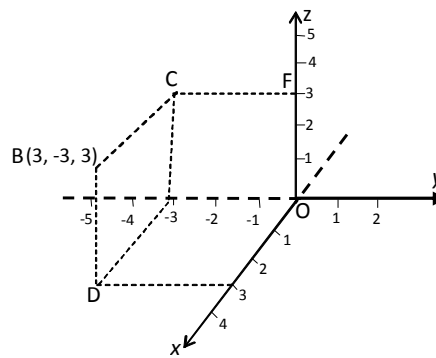

Figure 6.5 (Example 2)

Example 2 Locate the point $B(3, -3, 3)$ in space using the reference axes x , y and z .

The process of locating the point B may be described as follows: Start from the origin O and move 3 units in the direction of the positive x -axis. Then move 3 units in the direction of the negative y -axis and finally move 3 units up in the direction of the positive z -axis to get point B .

On the same coordinate system of **Example 2** above, notice that the coordinates of point C are $(0, -3, 3)$, the coordinates of point D are $(3, -3, 0)$, coordinates of point F are $(0, 0, 3)$ and the coordinates of point O (or the origin) are $(0, 0, 0)$.

Locating a given point in space as observed from the different examples above can be considered as corresponding or matching a given ordered triple of real numbers (x, y, z) with some point P in space. (See **Problems 3, 4 and 5 of Exercise 6.1**.)

Using this fact, it is possible to describe some geometric figures in space by means of equations. For example, the x -axis is the set of all points in space whose y and z coordinates are zero. Thus we express it as follows:

$$x\text{-axis} = \{(x, y, z): x, y, z \in \mathbb{R} \text{ and } y = z = 0\}$$

Exercise 6.1

1 Locate each of the following points in space using reference axes x , y and z . You may use the same or different coordinate systems in each case.

- | | | | | | |
|----------|----------------|----------|---------------|----------|----------------------------|
| a | $P(3, 2, 3)$ | b | $Q(-2, 4, 3)$ | c | $R(3, -3, 4)$ |
| d | $T(-2, -3, 3)$ | e | $M(0, 0, -4)$ | f | $N(2.5, -\frac{1}{2}, -3)$ |
| g | $Q(0, -3, 0)$ | | | | |

2 Give the equations of

- | | | | | | |
|----------|-----------------|----------|-----------------|----------|-----------------|
| a | the y -axis | b | the z -axis | c | the xy -plane |
| d | the xz -plane | e | the yz -plane | | |

- 3** Given any point P in space, draw a coordinate system and
- drop a perpendicular line to the xy -plane.
 - mark the intersection point of the perpendicular line and the xy -plane by Q .
 - measure the distance from P to Q with a ruler and mark the same value on the z -axis. Call it z .
 - drop perpendicular lines to each of the x - and the y -axes from point Q and mark the intersection points on the axes, say x and y .
 - the triple (x, y, z) you found in the above steps uniquely corresponds to the point. Verify! Thus (x, y, z) are the coordinate of P in space.
- 4** Given any ordered triple (a, b, c) :
- draw a coordinate space and label each axis.
 - mark a on the x -axis, b on the y -axis and c on the z -axis.
 - From a , draw a line parallel to the y -axis and, from b , draw a line parallel to the x -axis; find the intersection of the two lines: mark it as point R .
 - From point R , draw a line parallel to the z -axis, and from c , draw a line perpendicular to the z -axis that intersects the line from R . Mark the intersection of these two lines by point P .
 - The point P in space corresponds to the ordered triple (a, b, c) . Verify that there is no other point in space describing the ordered triple (a, b, c) . Thus, (a, b, c) are the coordinates of P .
- 5** Can you conclude from the above two problems, **Problems 3** and **4**, that there is a one-to-one correspondence between the set of points in space and the set of ordered triples of real numbers? Why? You may need to use the basic facts in solid geometry about parallel and perpendicular lines and planes in space.

6.3 DISTANCE BETWEEN TWO POINTS IN SPACE



OPENING PROBLEM

Assume that your classroom is a rectangular box where the floor is 8 metres long and 6 metres wide. If the distance from the floor to the ceiling (height of the room) is 3 metres, find the diagonal distance between a corner of the room on the floor and the opposite corner on the ceiling.

After completing this section, you will see that solving this problem is a matter of finding distance between two points in space using their coordinates.

ACTIVITY 6.3



- 1** On the coordinate plane, consider points $P(x_1, y_1)$ and $Q(x_2, y_2)$ to be any two distinct points. Then find the distance between P and Q or the length of the line segment PQ by using the Pythagoras theorem.

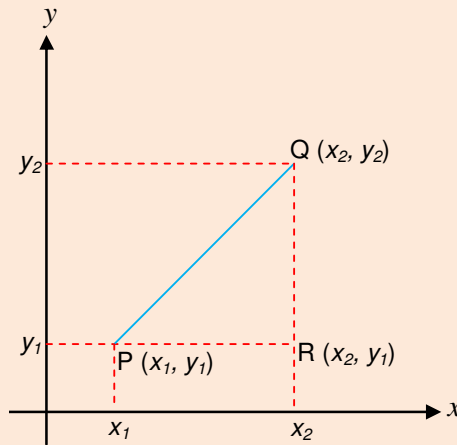

Figure 6.6

- 2** Find the distance between the following pairs of points.
- a** $A(3,4,0)$ and $B(1,5,0)$ **b** $C(0,3,4)$ and $D(0,1,2)$
- c** $E(4,0,5)$ and $F(1,0,1)$

The same principle which you use in two dimensions can be used to find the distance between two points in space whose coordinates are given.

First, let us consider the distance of a point $P(x, y, z)$ from the origin O of the coordinate system.

From the point $P(x, y, z)$, let us drop perpendicular line segments to the three planes and let us complete the rectangular box whose edges are x , y and z units long as shown in **Figure 6.7**. Let its vertices be named O, A, B, C, D, P, Q and R .

Then, to find the distance from O to point P , consider the right angled triangles OAB and OBP .

Here notice that \overline{PB} is perpendicular to the xy -plane at B , and hence it is perpendicular to \overline{OB} at B .

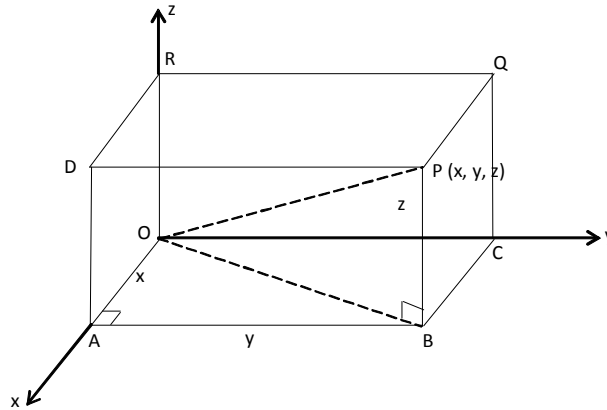

Figure 6.7

Now as \overline{OP} is the hypotenuse of the right angled triangle OBP , you know by Pythagoras theorem that $(OP)^2 = (OB)^2 + (PB)^2$

Once again, as \overline{OB} is the hypotenuse of the right angled triangle OAB , you have

$$(OB)^2 = (OA)^2 + (AB)^2.$$

Then substituting $(OB)^2$ by $(OA)^2 + (AB)^2$ in $(OP)^2 = (OB)^2 + (PB)^2$, you obtain

$$(OP)^2 = (OA)^2 + (AB)^2 + (PB)^2 = x^2 + y^2 + z^2$$

or
$$OP = \sqrt{x^2 + y^2 + z^2}$$

Note:

Observe that \overline{OP} is a diagonal of the rectangular box and x , y and z , in absolute value, are the lengths of its three concurrent edges. Therefore, the distance from O to P is now the length of the diagonal of the rectangular box which is the square root of the sum of the squares of the lengths of the three edges of the box.

Example 1 Find the distance from the origin to the point $P(3, 4, 5)$.

Solution The distance from the origin to the point P is the length of the line segment \overline{OP} , which is

$$OP = \sqrt{x^2 + y^2 + z^2} = \sqrt{3^2 + 4^2 + 5^2} = 5\sqrt{2} \text{ units}$$

Example 2 Find the distance from the origin to the point $Q(-2, 0, 3)$

Solution $OQ = \sqrt{(-2)^2 + 0^2 + 3^2} = \sqrt{13}$ units

Now, let $P(x_1, y_1, z_1)$ and $Q(x_2, y_2, z_2)$ be any two points in space. To find the distance between these two given points, you may consider a rectangular box in the coordinate space so that the given points P and Q are its opposite vertices or \overline{PQ} is its diagonal as shown in **Figure 6.8**.

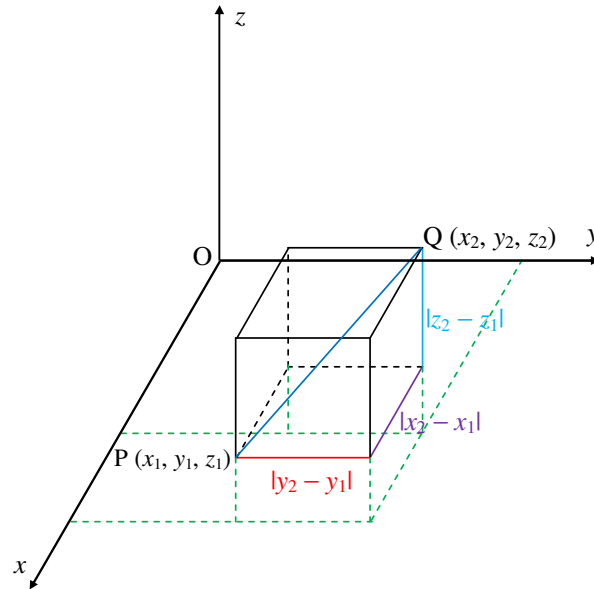

Figure 6.8

Then we see that the lengths of the three concurrent edges of the box are given by $|x_2 - x_1|$, $|y_2 - y_1|$ and $|z_2 - z_1|$.

Thus, the distance from P to Q or the length of the diagonal \overline{PQ} of the box, is given by

$$PQ = \sqrt{(x_2 - x_1)^2 + (y_2 - y_1)^2 + (z_2 - z_1)^2}$$

Example 3 Find the distance between the points $P(1, -2, 3)$ and $Q(-4, 0, 5)$

Solution $PQ = \sqrt{(x_2 - x_1)^2 + (y_2 - y_1)^2 + (z_2 - z_1)^2} = \sqrt{(-4-1)^2 + (0-(-2))^2 + (5-3)^2}$
 $= \sqrt{25 + 4 + 4} = \sqrt{33}$ units

Exercise 6.2

- 1 Find the distance between the given points in space.

a $A(0, 1, 0)$ and $B(2, 0, 3)$	b $C(2, 1, 3)$ and $D(4, 6, 10)$
c $E(-1, -3, 6)$ and $F(4, 0, -2)$	d $G(7, 0, 0)$ and $H(0, -4, 2)$
e $L\left(-1, -\frac{1}{2}, -\frac{1}{4}\right)$ and $M(-4, 0, -1)$	f $N(7, 11, 12)$ and $P(-6, -2, 0)$
g $Q(\sqrt{2}, -\sqrt{2}, 1)$ and $R(0, 0, -11)$	
- 2 Can you now solve the opening problem? Please try it.

6.4 MIDPOINT OF A LINE SEGMENT IN SPACE

ACTIVITY 6.4



On the coordinate plane, if $P(x_1, y_1)$ and $Q(x_2, y_2)$ are the endpoints of a line segment \overline{PQ} , you know that its midpoint M has coordinates

$$\left(\frac{x_1 + x_2}{2}, \frac{y_1 + y_2}{2} \right).$$

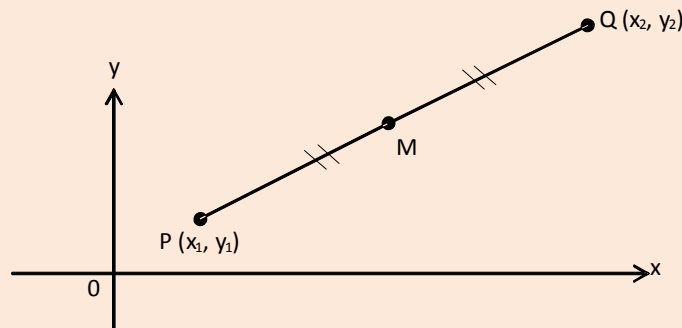

Figure 6.9

- 1 Find the coordinates of the midpoints of the line segments with given end points on a plane.
 - a $A(2,4)$ and $B(0,2)$
 - b $C(-1,3)$ and $D(3,-1)$
 - c $E\left(\frac{1}{4}, -\frac{3}{4}\right)$ and $F\left(\frac{3}{4}, \frac{3}{4}\right)$
- 2 Find the coordinates of the midpoints of the line segments with given end points in space.
 - a $A(2,4,0)$ and $B(0,2,0)$
 - b $C(-1,3,0)$ and $D(3,-1,0)$
 - c $E\left(\frac{1}{4}, -\frac{3}{4}, 0\right)$ and $F\left(\frac{3}{4}, \frac{3}{4}, 0\right)$

The coordinates of the midpoint of a line segment in space are also obtained in the same way. That is, the coordinates of the midpoint are obtained by taking the averages of the respective coordinates of the endpoints of the given line segment. Thus, if $P(x_1, y_1, z_1)$ and $Q(x_2, y_2, z_2)$ are the end points of a line segment in space, the coordinates of its midpoint M will be $\left(\frac{x_1 + x_2}{2}, \frac{y_1 + y_2}{2}, \frac{z_1 + z_2}{2} \right)$ See Figure 6.10.

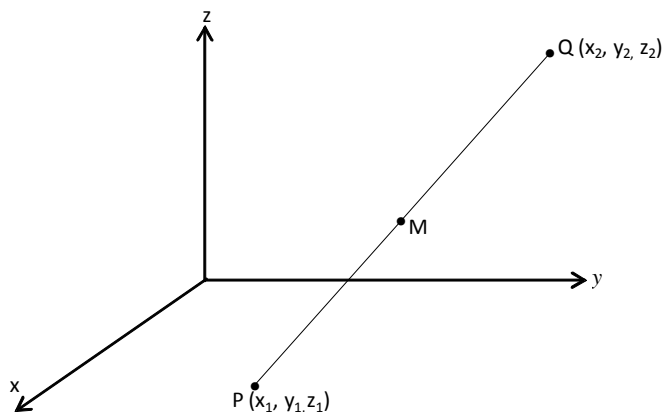

Figure 6.10

Example 1 Find the midpoint of the line segment with endpoints $A(0, 0, 0)$ and $B(4, 6, 2)$.

Solution The midpoint of \overline{AB} will be at the point M whose coordinates are

$$\left(\frac{0+4}{2}, \frac{0+6}{2}, \frac{0+2}{2}\right) = (2, 3, 1).$$

That is, $M(2, 3, 1)$ is the midpoint of \overline{AB} .

Example 2 Find the midpoint of the line segment whose endpoints are $P(-1, 3, -3)$ and $Q(1, 5, 7)$.

Solution The midpoint of \overline{PQ} is at the point M whose coordinates are

$$\left(\frac{-1+1}{2}, \frac{3+5}{2}, \frac{-3+7}{2}\right) = (0, 4, 2).$$

So, the point $M(0, 4, 2)$ is the midpoint of \overline{PQ} .

Exercise 6.3

- 1 Find the midpoint of the line segment whose endpoints are:

a $A(1, 3, 5)$ and $B(3, 1, 1)$	b $P(0, -2, 2)$ and $Q(-4, 2, 4)$
c $C\left(\frac{1}{2}, 3, 0\right)$ and $D\left(\frac{3}{4}, -1, 1\right)$	d $R(0, 9, 0)$ and $S(0, 0, 8)$
e $T(-2, -3, -5)$ and $U(-1, -1, -7)$	f $G(6, 0, 0)$ and $H(0, -4, -2)$
g $M\left(\frac{1}{2}, \frac{1}{3}, -1\right)$ and $K\left(-\frac{1}{2}, 0, \frac{1}{4}\right)$	
- 2 If the midpoint of a line segment is at $M(2, 5, -3)$ and one of its endpoints is at $R(-3, 2, 4)$, find the coordinates of the other endpoint.

6.5 EQUATION OF SPHERE

ACTIVITY 6.5



When the centre of a circle is at (h, k) and its radius is r , the equation of the circle is given by $(x - h)^2 + (y - k)^2 = r^2$

Here notice that $C(h, k)$ is the centre and $P(x, y)$ is any point on the circle and r is the radius of the circle or the distance of $P(x, y)$ from the centre $C(h, k)$.

Now using similar notions:

- 1 Define a sphere whose radius is r and whose centre is at (a, b, c) .
- 2 **a** Find the equation of the sphere whose centre is at the origin, and has radius $r = 2$.
- b** If a point $P(x, y, z)$ is on the surface of this sphere, what is the distance of P from the centre of the sphere?
- 3 If the centre of a sphere is at the origin and r is its radius, what is the distance of a point $P(3, 4, 0)$ on the surface of the sphere from the origin?

Now, let us consider a sphere whose centre is at the origin of a coordinate system and whose radius is r . Then, if $P(x, y, z)$ is any point on the surface of the sphere, the length of \overline{OP} is the radius of that sphere. In the discussion above, you have seen that the length of \overline{OP} is given by $\sqrt{x^2 + y^2 + z^2}$. Therefore, every point $P(x, y, z)$ on the sphere satisfies the equation $r = \sqrt{x^2 + y^2 + z^2}$.

That means, if the centre of a sphere is at the origin of the coordinate space and r is its radius, the equation of such a sphere is given by $x^2 + y^2 + z^2 = r^2$

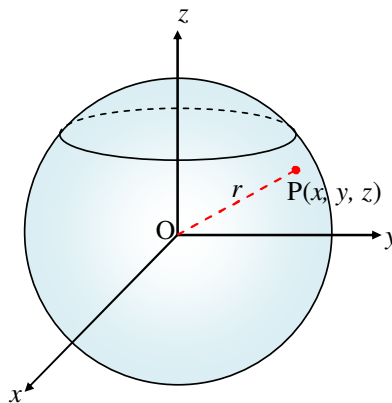

Figure 6.11

Example 1 Write the equation of the sphere whose centre is at the origin and whose radius is 3 units.

Solution If $P(x, y, z)$ is any point on the sphere, its distance from the origin (the centre) is given by $d = \sqrt{x^2 + y^2 + z^2}$. Substituting d by 3, we get the equation of the sphere to be $\sqrt{x^2 + y^2 + z^2} = 3$, which is equivalent to $x^2 + y^2 + z^2 = 9$.

Therefore, the equation of the sphere will be $x^2 + y^2 + z^2 = 9$.

Now let us consider a sphere whose centre is not at the origin but at any other point $C(a, b, c)$ in space. If $P(x, y, z)$ is any point on the surface of the sphere, then the radius of the sphere will be the length of \overline{CP} .

That means, in this case $r = \sqrt{(x-a)^2 + (y-b)^2 + (z-c)^2}$

Therefore, the equation of the sphere in this case is

$$(x-a)^2 + (y-b)^2 + (z-c)^2 = r^2$$

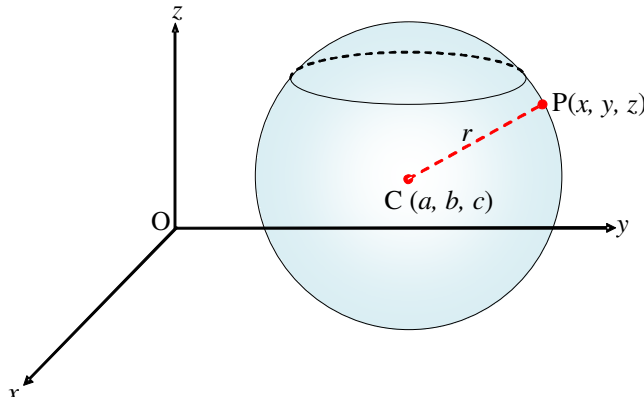

Figure 6.12

Example 2 Write the equation of the sphere with centre at $C(1, 2, 3)$ and radius 4 units.

Solution If $P(x, y, z)$ is any point on the surface of the sphere, then the distance from the centre C to the point P is given to be the radius of the sphere.

That means $r = \sqrt{(x-1)^2 + (y-2)^2 + (z-3)^2}$

Substituting r by 4 and squaring both sides, you get the equation of the sphere to be:

$$(x-1)^2 + (y-2)^2 + (z-3)^2 = 16.$$

Observe that when the centre is at the origin $(0, 0, 0)$ the equation

$$(x-a)^2 + (y-b)^2 + (z-c)^2 = r^2 \text{ reduces to the form } x^2 + y^2 + z^2 = r^2.$$

(Substituting (a, b, c) by $(0, 0, 0)$).

That means the equation of a sphere given by $(x-a)^2 + (y-b)^2 + (z-c)^2 = r^2$, where r is the radius and $C(a, b, c)$ is the centre can be applied to a sphere whose centre is at any point $C(a, b, c)$ including the origin.

Example 3 Given the equation of a sphere to be $x^2 + y^2 + z^2 = 9$, what can you say about the points:

- a** $P(1, 2, 2)$? **b** $Q(0, 1, 2)$? **c** $R(1, 3, 2)$?

Solution Clearly the centre of the sphere is at the origin $O(0, 0, 0)$ and its radius is 3.

- a** Because the distance of P from the centre is 3, P is on the surface of the sphere.
b Because the distance of Q from the centre is $\sqrt{5}$, which is less than 3, Q is inside the sphere.
c Because the distance of R from the centre is $\sqrt{14} > 3$, R is outside the sphere.

In general, if O is the centre of a sphere and r is its radius, then for any point P taken in space, we have one of the following three possibilities.

- i** $OP = r$, in which case P is on the surface of the sphere;
ii $OP < r$, in which case P is inside the sphere; and
iii $OP > r$, in which case P is outside the sphere.

Exercise 6.4

- 1** Write the equation of a sphere of radius 4 cm whose centre is at $O(3, 0, 5)$.
- 2** Given the equation of a sphere to be $x^2 + y^2 + z^2 - 6x - 4y - 10z = -22$, find the centre and radius of the sphere.
- 3** If $A(0, 0, 0)$ and $B(4, 6, 0)$ are end points of a diameter of a sphere, write its equation.
- 4** How far is the point $P(3, -1, 2)$ from the sphere whose equation is $(x - 1)^2 + (y + 2)^2 + z^2 = 1$?
- 5** If the centre of a sphere is at the origin and its radius is 10 units, determine which of the following points lie inside or outside or on the sphere.
 $A(2, 1, 2)$ $B(-3, 2, 4)$ $C(5, 8, 6)$ $D(0, 8, 6)$ $E(-8, -6, 0)$
- 6** Decide whether or not each of the following points is inside, outside or on the sphere whose equation is $x^2 + y^2 + z^2 + 2x - y + z = 0$.
a $O(0, 0, 0)$ **b** $P(-1, 0, 1)$ **c** $Q(0, \frac{1}{2}, 0)$
- 7** **a** State the coordinates of any point in space which is on the z axis.
b Find the coordinates of two points on the x -axis which are $\sqrt{12}$ units from the point $P(-1, -1, 2)$.

6.6 VECTORS IN SPACE

Recall that a vector quantity is a quantity that has both magnitude and direction. In physics, velocity and force are examples of vector quantities. On the other hand, a quantity that has magnitude only but no direction is called a scalar quantity. For example, mass and speed are examples of scalar quantities.

ACTIVITY 6.6

- 1 How do you represent a vector on a plane?
- 2 How do you represent the magnitude of a vector?
- 3 How do you show the direction of a vector?
- 4 How do you express the vector in **Figure 6.13** below using the standard unit vectors \mathbf{i} and \mathbf{j} ?

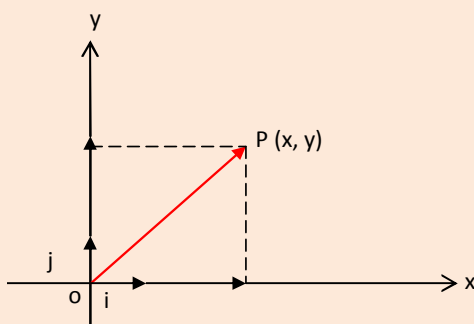

Figure 6.13

Recall also that the vector \overline{OP} can be named using a single letter. That is, \overline{OP} may be named \vec{a} , or simply by \mathbf{a} so that $\vec{a} = \mathbf{a} = x\mathbf{i} + y\mathbf{j}$

Operations on vectors can be performed using their components or the coordinates of their terminal points when their initial points, are at the origin of the coordinate system.

Example 1 If $\vec{a} = 2\mathbf{i} + 4\mathbf{j}$ and $\vec{b} = 5\mathbf{i} + 3\mathbf{j}$, then find

- i** $\vec{a} + \vec{b}$ **ii** $\vec{a} - \vec{b}$

Solution

i $\vec{a} + \vec{b} = (2\mathbf{i} + 4\mathbf{j}) + (5\mathbf{i} + 3\mathbf{j}) = (2+5)\mathbf{i} + (4+3)\mathbf{j} = 7\mathbf{i} + 7\mathbf{j}$

ii $\vec{a} - \vec{b} = (2\mathbf{i} + 4\mathbf{j}) - (5\mathbf{i} + 3\mathbf{j}) = (2-5)\mathbf{i} + (4-3)\mathbf{j} = -3\mathbf{i} + \mathbf{j}$

Notice that the terminal points of the vectors \vec{a} and \vec{b} are at (2, 4) and (5, 3) respectively, while the terminal point of the vector $\vec{a} + \vec{b}$ is at (7, 7) which can be obtained by adding the corresponding coordinates of the terminal points of the two vectors \vec{a} and \vec{b} . You may also look at **Figure 6.14** below.

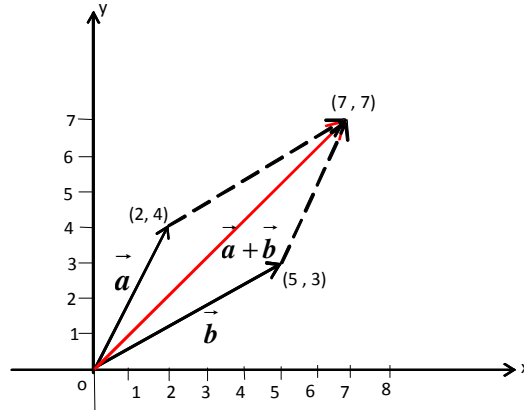

Figure 6.14

In your previous studies, you have also learned about the scalar or dot product of two vectors. That is, if θ is the angle between the two vectors \vec{a} and \vec{b} , the dot or scalar product of \vec{a} and \vec{b} denoted by $\vec{a} \cdot \vec{b}$ is defined as:

$(\vec{a}) \cdot (\vec{b}) = |\vec{a}| |\vec{b}| \cos \theta$, where $|\vec{a}|$ and $|\vec{b}|$ are the magnitudes of the two vectors \vec{a} and \vec{b} respectively.

Example 2 Compute the scalar product of the vectors $\vec{a} = 3\mathbf{i} + 3\mathbf{j}$ and $\vec{b} = 4\mathbf{i} + 0\mathbf{j}$.

Solution By picturing a diagram, the angle between the two vectors is 45° .

$$\text{Then, } |\vec{a}| = \sqrt{3^2 + 3^2} = 3\sqrt{2} \quad \text{and} \quad |\vec{b}| = \sqrt{4^2 + 0^2} = 4$$

$$\text{Thus } \vec{a} \cdot \vec{b} = |\vec{a}| \cdot |\vec{b}| \cos \theta = 3\sqrt{2} (4) \cos 45^\circ = 12.$$

Or

$$\begin{aligned} \vec{a} \cdot \vec{b} &= (3\mathbf{i} + 3\mathbf{j}) \cdot (4\mathbf{i} + 0\mathbf{j}) = (3 \times 4)\mathbf{i} \cdot \mathbf{i} + (3 \times 0)\mathbf{i} \cdot \mathbf{j} + (3 \times 4)\mathbf{j} \cdot \mathbf{i} + (3 \times 0)\mathbf{j} \cdot \mathbf{j} \\ &= 12 + 0 + 0 + 0 = 12. \end{aligned}$$

The notion of vectors in space

Just as you worked with vectors on a plane by using the coordinates of their terminal points, you can handle vectors in a three dimensional space with the help of the coordinates of the terminal points.

Now, let the initial point of a vector in space be the origin O of the coordinate system and let its terminal point be at $A(x, y, z)$. Then the vector \vec{OA} can be expressed as the sum of its three components in the directions of the x , the y and the z -axis, in the form:

$\overline{OA} = x\mathbf{i} + y\mathbf{j} + z\mathbf{k}$ where $\mathbf{i} = (1, 0, 0)$, $\mathbf{j} = (0, 1, 0)$ and $\mathbf{k} = (0, 0, 1)$ are standard unit vectors in the directions of the positive x , positive y and positive z -axis, respectively. Look at **Figure 6.15** below.

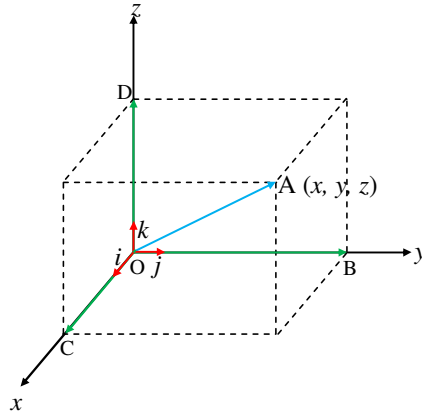

Figure 6.15

Do you observe that the vector \overline{OA} is the sum of the three perpendicular vectors \overline{OC} , \overline{OB} and \overline{OD} ?

Example 3 If the initial point of a vector in space is at the origin and its terminal point or head is at $P(3, 5, 4)$, show the vector using a coordinate system and identify its three perpendicular components in the directions of the three axes.

Solution The three components are the vectors with common initial point $O(0, 0, 0)$ and terminal points $A(3, 0, 0)$ on the x -axis, $B(0, 5, 0)$ on the y -axis and $C(0, 0, 4)$ on the z -axis as shown in **Figure 6.16**.

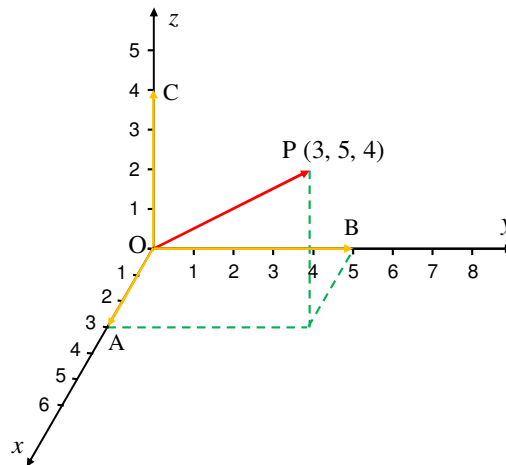

Figure 6.16

That means, $\overline{OP} = \overline{OA} + \overline{OB} + \overline{OC}$ or in terms of the unit vectors,
 $(3, 5, 4) = 3\mathbf{i} + 5\mathbf{j} + 4\mathbf{k} = (3, 0, 0) + (0, 5, 0) + (0, 0, 4)$

Addition and subtraction of vectors

Just as with vectors on the xy -plane, vectors in space can be added using the coordinates of their terminal points when their initial points are at the origin. That is, if \vec{a} and \vec{b} are vectors in space with their initial points at the origin and their terminal points at (x_1, y_1, z_1) and (x_2, y_2, z_2) , respectively, then $\vec{a} + \vec{b}$ is the vector with initial point at the origin and terminal point at $(x_1 + x_2, y_1 + y_2, z_1 + z_2)$.

Here, it is advantageous to note that a vector \vec{v} with initial point at the origin and terminal point at point $P(x, y, z)$ in space is shortly expressed as $\vec{v} = \overrightarrow{OP} = (x, y, z)$. Thus $\vec{v} = (3, 2, -4)$ is the vector in space with initial point at the origin and terminal point at $(3, 2, -4)$.

Example 4 If $\vec{a} = (1, 3, 2)$ and $\vec{b} = (3, -1, 4)$, find the sum vector $\vec{a} + \vec{b}$.

Solution As explained above, the sum of the two vectors is obtained by adding the corresponding coordinates of the terminal points of the two vectors.

That is $\vec{a} + \vec{b} = (1, 3, 2) + (3, -1, 4) = (4, 2, 6)$ which means that $\vec{a} + \vec{b}$ is the vector whose initial point is the origin and whose terminal point is at $(4, 2, 6)$.

Subtraction of a vector from a vector is also done in a similar way. So if we are given two vectors $\vec{a} = (x_1, y_1, z_1)$ and $\vec{b} = (x_2, y_2, z_2)$ then $\vec{a} - \vec{b}$ is the vector $\vec{c} = (x_1 - x_2, y_1 - y_2, z_1 - z_2)$.

Example 5 If $\vec{a} = (5, 2, 3)$ and $\vec{b} = (3, 1, 4)$ then find $\vec{a} - \vec{b}$ and $\vec{b} - \vec{a}$

Solution

i $\vec{a} - \vec{b} = (5, 2, 3) - (3, 1, 4) = (5-3, 2-1, 3-4) = (2, 1, -1)$

That means $\vec{a} - \vec{b}$ is the vector with initial point at the origin and terminal point at $(2, 1, -1)$ in space.

ii $\vec{b} - \vec{a} = (3, 1, 4) - (5, 2, 3) = (3-5, 1-2, 4-3) = (-2, -1, 1)$.

Do you see that $\vec{a} - \vec{b} \neq \vec{b} - \vec{a}$?

Multiplication of a vector by a scalar

If $\vec{a} = (x, y, z)$ then observe that

$$2\vec{a} = \vec{a} + \vec{a} = (x, y, z) + (x, y, z) = (x + x, y + y, z + z) = (2x, 2y, 2z).$$

Thus, it will be reasonable to accept the following: If $\vec{a} = (x, y, z)$ is any vector and k is any scalar (a number), then

$k\vec{a} = (kx, ky, kz)$ which is a vector with initial point at the origin and terminal point at (kx, ky, kz) .

Example 6 If $\vec{a} = (4, 2, 3)$, then

a $3\vec{a} = (12, 6, 9)$

b $-\vec{a} = (-4, -2, -3)$

c $-2\vec{a} = (-8, -4, -6)$

d $\frac{1}{2}\vec{a} = (2, 1, \frac{3}{2})$

Properties of addition of vectors

Since vector addition is done using the coordinates of the terminal points of the addend vectors, which are real numbers, you can easily verify the following properties of vector addition.

i Vector addition is commutative

For any two vectors $\vec{a} = (x_1, y_1, z_1)$ and $\vec{b} = (x_2, y_2, z_2)$ in space,

$\vec{a} + \vec{b} = \vec{b} + \vec{a}$. To see this, let us look at the following.

$$\begin{aligned}\vec{a} + \vec{b} &= (x_1, y_1, z_1) + (x_2, y_2, z_2) = (x_1+x_2, y_1+y_2, z_1+z_2) = (x_2+x_1, y_2+y_1, z_2+z_1) \text{ Why?} \\ &= (x_2, y_2, z_2) + (x_1, y_1, z_1) = \vec{b} + \vec{a}\end{aligned}$$

ii Vector addition is associative

For any three vectors \vec{a} , \vec{b} and \vec{c} in space, $\vec{a} + (\vec{b} + \vec{c}) = (\vec{a} + \vec{b}) + \vec{c}$

iii For two vectors \vec{a} and \vec{b} and any scalar k , you have $k(\vec{a} + \vec{b}) = k\vec{a} + k\vec{b}$.

Magnitude of a vector

At the beginning of the discussion about vectors in space, it was mentioned that a vector is usually represented by an arrow, where the arrow head indicates the direction and the length of the arrow represents the magnitude of the vector. Thus, to find the magnitude of a vector, it will be sufficient to find the distance between the initial point and the terminal point of the vector in the coordinate space.

For example, if the initial point of a vector is at the origin of the coordinate space and the terminal point is at P(3, 2, 4) then the magnitude of the vector \overline{OP} is the distance from O to P. This is, as you know, $\sqrt{3^2 + 2^2 + 4^2} = \sqrt{29}$

Thus, in general, if the initial point of a vector \vec{v} is at the origin and its terminal point is at a point Q(x, y, z) or if $\vec{v} = x\mathbf{i} + y\mathbf{j} + z\mathbf{k}$, then magnitude of the vector \vec{v} , denoted by $|\vec{v}|$ is given by $\sqrt{x^2 + y^2 + z^2}$. That is,

$$|\vec{v}| = \sqrt{x^2 + y^2 + z^2}$$

If the initial point of \vec{v} is at P(x_1, y_1, z_1) and the terminal point at Q(x_2, y_2, z_2), then

$$|\vec{v}| = \sqrt{(x_2 - x_1)^2 + (y_2 - y_1)^2 + (z_2 - z_1)^2}.$$

Scalar or dot product of vectors in space

When you were studying vectors on a plane, you saw that the dot product (scalar product) of two vectors \vec{a} and \vec{b} was defined by:

$\vec{a} \cdot \vec{b} = |\vec{a}| |\vec{b}| \cos \theta$ where θ is the angle between the two vectors. In particular, for the unit vectors \vec{i} and \vec{j} , you know that $|\vec{i}| = |\vec{j}| = 1$ and from the definition of the dot product, you easily see that $\vec{i} \cdot \vec{i} = \vec{j} \cdot \vec{j} = 1$ and $\vec{i} \cdot \vec{j} = 0 = \vec{j} \cdot \vec{i}$. So, if $\vec{a} = (x_1, y_1)$, and, $\vec{b} = (x_2, y_2)$ the dot product $\vec{a} \cdot \vec{b} = x_1 x_2 + y_1 y_2$ can be verified very easily.

The dot (scalar) product of two vectors in space is just an extension of the dot product of vectors on a plane. That means if \vec{a} and \vec{b} are now two vectors in space, the dot (scalar) product of \vec{a} and \vec{b} denoted by $\vec{a} \cdot \vec{b}$ is defined as:

$\vec{a} \cdot \vec{b} = |\vec{a}| |\vec{b}| \cos \theta$ where θ is once again the angle between the two vectors \vec{a} and \vec{b} . Observe that $\vec{a} \cdot \vec{b}$ is a real number and in particular if

$\vec{a} = (x_1, y_1, z_1) = x_1 \vec{i} + y_1 \vec{j} + z_1 \vec{k}$ and $\vec{b} = (x_2, y_2, z_2) = x_2 \vec{i} + y_2 \vec{j} + z_2 \vec{k}$, you see that, the distributive property of multiplication over addition enables you to find:

$$\vec{a} \cdot \vec{b} = (x_1 \vec{i} + y_1 \vec{j} + z_1 \vec{k}) \cdot (x_2 \vec{i} + y_2 \vec{j} + z_2 \vec{k}) = x_1 x_2 + y_1 y_2 + z_1 z_2.$$

Here it is important to note that for the unit vectors \vec{i} , \vec{j} and \vec{k} ,

$\vec{i} \cdot \vec{i} = \vec{j} \cdot \vec{j} = \vec{k} \cdot \vec{k} = 1$ while $\vec{i} \cdot \vec{j} = \vec{i} \cdot \vec{k} = \vec{k} \cdot \vec{j} = 0$ the reason being that the magnitude of a unit vector is one, $\cos 90^\circ = 0$ and $\cos 0^\circ = 1$.

Example 7 If $\vec{a} = (2, 3, -1)$ and $\vec{b} = (-1, 0, 2)$, then find the scalar (dot) product of \vec{a} and \vec{b} .

Solution $\vec{a} \cdot \vec{b} = x_1 x_2 + y_1 y_2 + z_1 z_2 = 2(-1) + 3(0) + (-1)(2) = -4$

Example 8 If $\vec{a} = (2, 0, 2)$ and $\vec{b} = (0, 3, 0)$ find their dot product.

Solution $\vec{a} \cdot \vec{b} = x_1 x_2 + y_1 y_2 + z_1 z_2 = 2(0) + 0(3) + 2(0) = 0$

Observe that $(2, 0, 2)$ and $(0, 3, 0)$ are perpendicular vectors i.e. the angle between them is 90° .

Exercise 6.5

1 Calculate the magnitude of each of the following vectors.

a $(-1, 3, 0)$ **b** $(3, 1, -1)$ **c** $\left(\frac{1}{2}, \frac{3}{2}, \frac{4}{5}\right)$

2 Find the scalar (dot) product of each of the following pairs of vectors.

a $(2, -3, 1)$ and $(1, 0, 4)$ **b** $(-5, 0, 1)$ and $(1, -3, -2)$
c $(-2, 2, 0)$ and $(0, 0, -1)$ **d** $(0, 0, 3)$ and $(0, 0, 3)$

Angle between two vectors in space

For two vectors \vec{a} and \vec{b} with initial point at the origin, their dot product is defined by

$\vec{a} \cdot \vec{b} = |\vec{a}| |\vec{b}| \cos \theta$ where θ is the angle between the two vectors, assuming that both vectors have the same initial point at the origin. Then solving for $\cos \theta$, you can rewrite the above equation in the form:

$$\cos \theta = \frac{\vec{a} \cdot \vec{b}}{|\vec{a}| |\vec{b}|}$$

Hence the angle θ between the two vectors can be obtained using this last formula, provided the vectors are non-zero.

Example 9 Find the angle between the vectors $\vec{a} = (2, 0, 0)$ and $\vec{b} = (0, 0, 3)$.

Solution
$$\cos \theta = \frac{\vec{a} \cdot \vec{b}}{|\vec{a}| |\vec{b}|}$$

But, $\vec{a} \cdot \vec{b} = 2(0) + (0)(0) + 0(3) = 0$

$|\vec{a}| = \sqrt{2^2 + 0^2 + 0^2} = \sqrt{2}$ and $|\vec{b}| = \sqrt{0^2 + 0^2 + 3^2} = 3$

Therefore $\cos \theta = \frac{0}{2(3)} = 0 \Rightarrow \theta = 90^\circ$

Notice that, the vector $(2, 0, 0)$ is along the x -axis while the vector $(0, 0, 3)$ is along the z -axis and the two axes are perpendicular to each other.

Example 10 Find the angle between the vectors $\vec{a} = (1, 0, 1)$ and $\vec{b} = (1, 1, 0)$.

Solution
$$\cos \theta = \frac{\vec{a} \cdot \vec{b}}{|\vec{a}| |\vec{b}|}$$

But, $\vec{a} \cdot \vec{b} = 1(1) + 0(1) + 1(0) = 1$

$|\vec{a}| = \sqrt{1^2 + 0^2 + 1^2} = \sqrt{2}$ and $|\vec{b}| = \sqrt{1^2 + 1^2 + 0^2} = \sqrt{2}$

Therefore $\cos \theta = \frac{1}{\sqrt{2} \cdot \sqrt{2}} = \frac{1}{2} \Rightarrow \theta = 60^\circ$

Notice that the vector \vec{a} is on the xz -plane and \vec{b} is on the xy -plane, each forming a 45° angle with the x -axis.

Exercise 6.6

- 1** If the vectors \vec{a} , \vec{b} , \vec{v} and \vec{u} are as given below:
- $$\vec{a} = (1, 3, 2), \vec{b} = (0, -3, 4), \vec{v} = (-4, 3, -2), \vec{u} = \left(\frac{1}{2}, 0, -3\right)$$
- then find each of the following vectors.
- a** $\vec{a} + \vec{b}$ **b** $\vec{b} + \vec{a}$ **c** $\vec{a} - \vec{b}$ **d** $\vec{b} - \vec{a}$
- e** $\vec{a} + \vec{b} + \vec{v}$ **f** $\vec{b} + \vec{v} - \vec{u}$ **g** $\vec{a} + \vec{b} + \vec{v} + \vec{u}$
- 2** If the vectors \vec{a} , \vec{b} , \vec{v} and \vec{u} are as given in **Question 1** above, then find
- a** $3\vec{a}$ **b** $-4\vec{b}$ **c** $2\vec{a} + 3\vec{b}$ **d** $3\vec{b} - \frac{1}{2}\vec{a} + 2\vec{v}$
- 3** Verify that vector addition is associative. That is, for any three vectors \vec{a} , \vec{b} and \vec{c} in space, show that $(\vec{a} + \vec{b}) + \vec{c} = \vec{a} + (\vec{b} + \vec{c})$
- 4** For any two vectors \vec{a} and \vec{b} in space and any scalar k , show that
- $$k(\vec{a} + \vec{b}) = k\vec{a} + k\vec{b}$$
- 5** Write each of the following vectors as a sum of its components using the standard unit vectors \mathbf{i} , \mathbf{j} and \mathbf{k} .
- a** $(-4, 3, -2)$ **b** $(1, -3, \sqrt{2})$
- c** $(3, 5, -7)$ **d** $(0, 0, 3)$
- 6** Show each of the following vectors in the coordinate space using an arrow that starts from the origin.
- a** $\vec{a} = (3, 3, 3)$ **b** $\vec{b} = (-3, 3, 4)$ **c** $\vec{c} = (2, -3, -3)$
- 7** Calculate the magnitude of each vector in **Question 6** above.
- 8** Find the scalar (dot) product of each of the following pairs of vectors.
- a** $(1, 0, 1)$ and $(2, 2, 0)$ **b** $(-2, 5, 1)$ and $(1, -1, -2)$
- c** $\left(\frac{1}{2}, \frac{1}{2}, \frac{1}{2}\right)$ and $\left(-\frac{3}{2}, -\frac{3}{2}, -\frac{1}{2}\right)$ **d** $(1, 0, 1)$ and $(-1, 1, 0)$
- e** $(5, 0, 0)$ and $(0, -5, 0)$ **f** $(2, 2, 2)$ and $(-1, -1, -1)$
- 9** Find the angle between each of the following pairs of vectors.
- a** $(2, 0, 1)$ and $(0, -1, 0)$ **b** $(1, 1, 1)$ and $(1, 0, 1)$
- c** $(-1, 1, 1)$ and $(2, 2, 2)$



Key Terms

angle between two vectors	mutually perpendicular lines
concurrent edges of a rectangular box	octants
coordinate planes	ordered triples of real numbers
coordinate system	reference axes
diagonal of a rectangular box	unit vectors
dot product of vectors	vector in space
magnitude of a vector	



Summary

- Three mutually perpendicular lines in space divide the space into **eight octants**.
- If (x, y, z) are the coordinates of a point P in space, then
 - ✓ x is the directed distance of the point from the yz -plane,
 - ✓ y is the directed distance of the point from the xz -plane,
 - ✓ z is the directed distance of the point from the xy -plane.
- There is a one to one correspondence between the set of all points of the space and the set of all ordered triples of real numbers.
- The distance between two points $P(x, y, z)$ and $Q(a, b, c)$ in space is given by

$$d = \sqrt{(x-a)^2 + (y-b)^2 + (z-c)^2}.$$
 Thus the distance of a point $P(x, y, z)$ from the origin is $\sqrt{x^2 + y^2 + z^2}$.
- The **midpoint** of a line segment with end points $A(x, y, z)$ and $B(a, b, c)$ in space is the point $M\left(\frac{x+a}{2}, \frac{y+b}{2}, \frac{z+c}{2}\right)$
- The **equation of a sphere** with centre at $C(x_1, y_1, z_1)$ and radius r is given by

$$(x-x_1)^2 + (y-y_1)^2 + (z-z_1)^2 = r^2$$
 In particular, if the centre is at the origin and r is the radius, the equation becomes $x^2 + y^2 + z^2 = r^2$, where (x, y, z) are coordinates of any point P on the surface of the sphere.
- In space, if the initial point of a vector is at the origin O of the coordinate system and its terminal point is at a point $A(x, y, z)$, then it can be expressed as the sum of its three components in the directions of the three axes as:

$$\overrightarrow{OA} = x\mathbf{i} + y\mathbf{j} + z\mathbf{k}$$
 where $\mathbf{i} = (1, 0, 0)$, $\mathbf{j} = (0, 1, 0)$ and $\mathbf{k} = (0, 0, 1)$ are the **standard unit vectors** in the directions of the positive x , positive y and positive z -axes respectively.

- 8** In space if vectors \vec{a} and \vec{b} have their initial point at the origin and their terminal points at $A(x_1, y_1, z_1)$ and $B(x_2, y_2, z_2)$ respectively, then their **sum** $\vec{a} + \vec{b}$ is a vector whose initial point is at the origin and terminal point is at $C(x_1 + x_2, y_1 + y_2, z_1 + z_2)$. Similarly, the **difference** $\vec{a} - \vec{b}$ is the vector whose initial point is at the origin and terminal point is at $D(x_1 - x_2, y_1 - y_2, z_1 - z_2)$.
- 9** If the initial point of a vector \vec{a} is at the origin and the terminal point is at $P(x, y, z)$, then for any constant number k , the product $k\vec{a}$ is a vector whose initial point is at the origin and terminal point is at $Q(kx, ky, kz)$.
- 10** Vector addition is commutative and also associative.
- 11** Multiplication of a vector by a scalar is distributive over vector addition. That is for vectors \vec{a} and \vec{b} and a scalar k , $k(\vec{a} + \vec{b}) = k\vec{a} + k\vec{b}$.
- 12** The magnitude of a vector \vec{a} with initial point at the origin and terminal point at $P(x, y, z)$ is given by:
- $$|\vec{a}| = \sqrt{x^2 + y^2 + z^2}$$
- 13** The **dot (scalar) product** of two vectors \vec{a} and \vec{b} is given by $\vec{a} \cdot \vec{b} = |\vec{a}| \cdot |\vec{b}| \cdot \cos \theta$, where θ is the angle between the two vectors \vec{a} and \vec{b} .
- 14** If θ is the angle between two vectors \vec{a} and \vec{b} , then $\cos \theta = \frac{\vec{a} \cdot \vec{b}}{|\vec{a}| \cdot |\vec{b}|}$.



Review Exercises on Unit 6

- 1** Locate the position of each of the following points and find the distance of each point from the origin.
- | | | |
|----------------------|---|----------------------|
| a O(0,0,-3) | b P(0,-1,2) | c Q(3,-1,4) |
| d R(-1,-2,-3) | e S(-3,-2,3) | f T(-3,-3,-4) |
| g U(4,3,-2) | h V(0, - $\frac{3}{2}$, $\frac{5}{2}$) | |
- 2** Find the distance of the point P (4, -3, 5) from the
- | | | | |
|-----------------|-------------------|-------------------|-------------------|
| a origin | b xy-plane | c xz-plane | d yz-plane |
| e x-axis | f y-axis | g z-axis | |
- 3** For each of the following pairs of points, find the distance from A to B and also find the midpoint of \overline{AB} .
- | | |
|------------------------------------|------------------------------------|
| a A (-1,2,3) and B (0,-1,1) | b A (3,-1,1) and B (-1,0,1) |
| c A (2,0,-3) and B (2,-1,3) | d A (0,0,-4) and B (4,0,0) |

- e** $A(-2, -1, -3)$ and $B(2, 2, 1)$ **f** $A\left(\frac{1}{2}, \frac{1}{2}, -\frac{1}{2}\right)$ and $B(10, 0, 11)$
- g** $A(\sqrt{2}, 5, 0)$ and $B\left(0, \frac{1}{2}, \sqrt{3}\right)$ **h** $A(0, 0, -2)$ and $B(0, 0, 5)$
- 4** Find the midpoint of the line segment whose end points are:
- a** $A(0, 0, 0)$ and $B(4, 4, 4)$ **b** $C(-2, -2, -2)$ and $D(2, 2, 2)$
- c** $P(6, 0, 0)$ and $Q(0, 4, 0)$ **d** $R(2\sqrt{2}, -4, 0)$ and $S(-2\sqrt{2}, 0, -5)$
- 5** Show that $A(0,4,4), B(2,6,5)$ and $C(1,4,3)$ are vertices of an isosceles triangle.
- 6** Determine the nature of $\triangle ABC$ using distances, if the vertices are at:
- a** $A(2,-1,7), B(3,1,4)$ and $C(5, 4,5)$
- b** $A(0,0,3), B(2,8,1)$ and $C(-9,6,18)$
- c** $A(1,0,-3), B(2,2,0)$ and $C(4,6,6)$
- d** $A(5, 6, -2), B(6, 12, 9)$ and $C(2, 4, 2)$
- 7** Make a three dimensional sketch showing each of the following vectors with initial point at the origin.
- a** $\vec{a} = 2\mathbf{i} + \mathbf{j} + 3\mathbf{k}$, **b** $\vec{b} = -3\mathbf{i} + 4\mathbf{j} - \mathbf{k}$,
- c** $\vec{c} = -3\mathbf{i} + 5\mathbf{j} + 5\mathbf{k}$, **d** $\vec{d} = 4\mathbf{j} - 7\mathbf{k}$.
- 8** Using the vectors in **Question 7** above, calculate each of the following.
- a** $\vec{a} + \vec{b}$ **b** $2\vec{a} - \vec{c}$ **c** $\vec{b} + \vec{c} + \vec{d}$ **d** $2\vec{a} - 3\vec{b} + \vec{c}$
- 9** Calculate the magnitude of each of the vectors in **Question 7** above.
- 10** A sphere has centre at $C(-1, 2, 4)$ and diameter AB , where A is at $(-2, 1, 3)$. Find the coordinates of B , the radius and the equation of the sphere.
- 11** Decide whether or not each of the following is an equation of a sphere. If it is an equation of a sphere, determine its centre and radius.
- a** $x^2 + y^2 + z^2 - 2y = 4$ **b** $x^2 + y^2 + z^2 - x + 2y - 3z + 4 = 0$
- c** $x^2 + y^2 + z^2 - 2x + 4y - 6z + 13 = 0$
- 12** Calculate the scalar (dot) product of each of the following pairs of vectors.
- a** $\vec{a} = (3, 2, -4)$ and $\vec{b} = (3, -2, 7)$ **b** $\vec{c} = (-1, 6, 5)$ and $\vec{d} = (10, 3, 1)$
- c** $\vec{p} = (2, 5, 6)$ and $\vec{q} = (6, 6, -7)$ **d** $\vec{a} = (7, 8, 9)$ and $\vec{b} = (5, -9, 5)$
- 13** For each pair of vectors given in **Question 12** above, find the cosine of θ , where θ is the angle between the vectors.

Unit



p	q	$p \Rightarrow q$	$(p \Rightarrow q) \wedge \neg q$	$[(p \Rightarrow q) \wedge \neg q] \Rightarrow \neg p$
T	T	T	F	T
T	F	F	F	T
F	T	T	F	T
F	F	T	T	T

MATHEMATICAL PROOFS

Unit Outcomes:

After completing this unit, you should be able to:

- develop the knowledge of logic and logical statements.
- understand the use of quantifiers and use them properly.
- determine the validity of arguments.
- apply the principle of mathematical induction for a problem that needs to be proved inductively.
- realize the rule of inference.

Main Contents

7.1 REVISION ON LOGIC

7.2 DIFFERENT TYPES OF PROOFS

7.3 PRINCIPLE AND APPLICATION OF MATHEMATICAL INDUCTION

Key Terms

Summary

Review Exercises

INTRODUCTION

In order to fully understand Mathematics, it is important to understand what makes up a correct mathematical argument, or proof. In this unit, you will be introduced to different methods of mathematical proof and you will also see the role of mathematical logic in proving mathematical statements. We will begin the unit by briefly revising mathematical logic.



OPENING PROBLEM

After completing this unit, you should be able to answer the following:

Consider the following arrangements of dots.

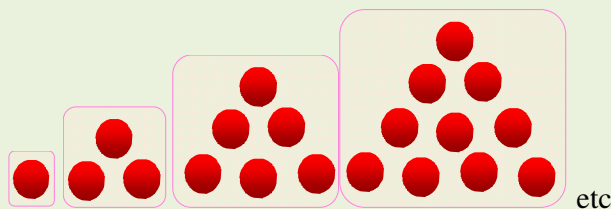

Number of dots	1	3	6	10
Sum of dots in row	1	1 + 2	1 + 2 + 3	1 + 2 + 3 + 4

Numbers like 1, 3, 6, 10, etc. are called triangular numbers.

- a** Can you list the next 5 triangular numbers?
- b** Can you give a formula for the i^{th} triangular number?
- c** Let T_i denote the i^{th} triangular number. Can you show that

$$\sum_{i=1}^n T_i = \frac{n(n+1)(n+2)}{6} ?$$

- d** Can you find $\sum_{i=1}^{40} T_i$?

7.1

REVISION ON LOGIC

Revision of Statements and Logical Connectives

In Unit 4 of your Grade 11 mathematics, you have studied statements and logical connectives (or operators):

negation (\neg), or (\vee), and (\wedge), implication (\Rightarrow) and bi-implication (\Leftrightarrow).

The following activities are designed to help you to revise these concepts.

ACTIVITY 7.1



- 1 What is meant by a statement (proposition)?
- 2 List the propositional connectives.
- 3 What is meant by a compound (complex) statement?
- 4 Review the rules of assigning truth values to complex propositions by completing the table below, where p and q are any two propositions.

p	q	$\neg p$	$p \wedge q$	$p \vee q$	$p \Rightarrow q$	$p \Leftrightarrow q$
T	T					
T	F					
F	T					
F	F					

- 5 Given statements p and q , each with truth value T, find the truth value of each of the following compound statements.

a $\neg p \vee q$ **b** $\neg(p \vee q)$ **c** $\neg q \Rightarrow \neg p$

d $\neg q \Leftrightarrow p$ **e** $\neg(p \wedge q)$

- 6 Construct a truth table for

a $\neg p \vee q$ **b** $(p \Rightarrow q) \Leftrightarrow \neg p$

c $(p \wedge q) \Rightarrow r$ **d** $\neg(p \Rightarrow q) \vee \neg r$

Open statements and quantifiers

ACTIVITY 7.2



Decide whether or not each of the following is a statement.

If it is a statement, determine its truth value.

- 1 x is a composite number.
- 2 If $3 + 2 = 7$, then $4 \times 9 = 32$.
- 3 $x + 2 = 15$, where x is an integer.
- 4 All prime numbers are odd.
- 5 There exists a prime number between 15 and 30.
- 6 All birds can fly.

As you may recall from your **Grade 11** lessons, the words **all** and **there exists** in questions 4, 5 and 6 of **Activity 7.2** are quantifiers.

Some of the sentences involve variables or unknowns and become statements when the variables or the unknowns are replaced by specific numbers or individuals; such sentences are called **open statements**.

Recall that open statements are denoted by $P(x)$ where x stands for the unknown and P stands for some property that is to be satisfied by x . For example, if we denote the open statement 1) above by $P(x)$, then P stands for the property of being a composite number while x is the variable or the unknown in the open statement.

Quantifiers

There is a way of changing an open statement into a statement without substituting individual(s) for the variable(s) involved by using what we call quantifiers. There are two types of quantifiers which are used to change an open statement into a statement, without any substitution. They are:

The universal quantifier denoted by \forall and
The existential quantifier denoted by \exists .

The notation $\forall x$ may be read in any one of the following ways:

for all x *for every x*
for each x *for any x*

The notation $\exists x$ may be read in any one of the following ways:

there exists x , *for at least one x ,* *for some x*

Example 1 Let $P(x) \equiv x > 5$ and $Q(x) \equiv x$ is an even number. Then determine the truth value of each of the following statements.

- a** $(\forall x) P(x)$ **b** $(\exists x) P(x)$
c $(\exists x) [P(x) \wedge Q(x)]$ **d** $(\forall x) [P(x) \Rightarrow Q(x)]$

Solution

- a** $(\forall x) P(x)$ is false, because if you take $x = 1$, then $1 > 5$ is false.
b $(\exists x) P(x)$ is true, because you can find an x , say $x = 7$ such that $7 > 5$ is true.
c $(\exists x) [P(x) \wedge Q(x)]$ is true, if you take $x = 6$, then $6 > 5$ and 6 is even.
d $(\forall x) [P(x) \Rightarrow Q(x)]$ is false, for $x = 7$, $P(7)$ is true but $Q(7)$ is false.

Example 2 Change the following open statement into a statement using quantifiers and determine the truth value.

$P(x): x^2 < 0$, where x is a complex number.

Solution Using the universal quantifier, $(\forall x) P(x)$ is false, because when x is a real number such as $x = 1$, $x^2 < 0$ is false.

Using the existential quantifier, $(\exists x) P(x)$ is true because when x is an imaginary number such as $x = i, 2i$, etc, $x^2 = -1, -4$, etc.

Exercise 7.1

- 1 Let $P(x) = x$ is a student who studied geometry.
Then, $(\forall x) P(x)$ is read as: _____
while $(\exists x) P(x)$ is read as: _____
- 2 Given the open statements:
 $P(x) \equiv x$ is a prime number. $Q(x) \equiv x$ is an odd number.
Determine the truth value of each of the following statements.
 - a $(\forall x) P(x)$ b $(\exists x) P(x)$ c $(\exists x) (\neg P(x))$
 - d $(\forall x) [P(x) \Rightarrow Q(x)]$ e $(\exists x) [P(x) \wedge \neg Q(x)]$
- 3 If x and y are integers, determine the truth value of each of the following.
 - a $(\exists x) (\forall y) (x \leq y)$ b $(\exists x) (\forall y) (x^2 \leq y)$
 - c $(\forall x) (\exists y) (x \leq y)$ d $(\forall x) (\forall y) (x + y = y + x)$
 - e $(\forall x) (\exists y) (x + y = 0)$
- 4 Express each of the following using quantifiers.
 - a Some students in this class have visited Gondar.
 - b Every student in this class has visited either Gondar or Hawassa.

Arguments and validity of arguments

ACTIVITY 7.3



- 1 Discuss whether or not the following conclusion is meaningful.
 - a If the day is cloudy, then it rains.
Does this mean that if it rains, there are clouds?
 - b If x is a prime number and y is a composite number, then $x + y$ is a composite number.
- 2 Construct a single truth table for the following statements.
 $p \Rightarrow q$, $\neg q \Rightarrow r$, and p .
Find out the rows in which the statements $p \Rightarrow q$ and $\neg q \Rightarrow r$ are both true but p is false.

An argument is an assertion that a given set of statements called the **premise (hypothesis)**, yields another statement, called the **conclusion (consequent)**.

An argument is said to be valid, if and only if the conjunction of all the premises always implies the conclusion. In other words, if we assume that the statements in the premises are all true, then (for a valid argument), the conclusion must be true. An argument which is not valid is called a fallacy.

The validity of an argument can easily be checked by constructing a truth table. All you must show is that the premises altogether always imply the conclusion. In other words, you show that "conjunction of the premises \Rightarrow conclusion" is always true (or a tautology).

To show the validity of an argument, you have to show that the conclusion is true whenever all the premises are true.

Example 3 Is the following argument valid?

If I am rich, then I am healthy.

I am healthy.

Therefore, I am rich.

Solution

Note that the first two statements are the premises while the last statement is the conclusion. This argument is not a valid argument. To see why, we shall first symbolize it.

Let p stand for the statement "I am rich" and let q stand for the statement "I am healthy".

Then, the symbolic form of the above argument becomes:

$$p \Rightarrow q$$

$$\frac{q}{p} \quad \text{or } p \Rightarrow q, q \vdash p$$

This argument would be valid, if the implication $[(p \Rightarrow q) \wedge q] \Rightarrow p$ were always true.

When you construct the truth table for this conditional statement as shown below, you see that the conclusion could be F while both the premises are true. (See the third line in the 5th column). In other words, $[(p \Rightarrow q) \wedge q] \Rightarrow p$ is not a tautology. Thus, the argument is invalid.

p	q	$p \Rightarrow q$	$(p \Rightarrow q) \wedge q$	$[(p \Rightarrow q) \wedge q] \Rightarrow p$
T	T	T	T	T
T	F	F	F	T
F	T	T	T	F
F	F	T	F	T

Example 4 Is the following argument valid?

If I am healthy, then I will be happy.

I am not happy.

Therefore, I am not healthy.

Solution Once again, to check the validity of this argument, symbolize it. Let p represent "I am healthy" and let q represent "I am happy". The symbolic form of the argument is:

$$p \Rightarrow q \qquad p \Rightarrow q, \neg q \vdash \neg p.$$

$$\frac{\neg q}{\neg p}$$

This argument will be valid, if the implication $[(p \Rightarrow q) \wedge \neg q] \Rightarrow \neg p$ is always true (a tautology). Constructing a truth table as shown below, you notice that the argument is valid.

p	q	$\neg p$	$\neg q$	$p \Rightarrow q$	$(p \Rightarrow q) \wedge \neg q$	$[(p \Rightarrow q) \wedge \neg q] \Rightarrow \neg p$
T	T	F	F	T	F	T
T	F	F	T	F	F	T
F	T	T	F	T	F	T
F	F	T	T	T	T	T

Example 5 Show that the following argument is valid.

If you send me an email, then I will finish writing my project.
 If I finish writing my project, then I will get relaxed.
 Therefore, if you send me an email, then I will get relaxed.

Solution

Let: $p \equiv$ you send me an email
 $q \equiv$ I finish writing my project
 $r \equiv$ I get relaxed. Then the symbolic form of this argument will be as follows.

$$p \Rightarrow q$$

$$\frac{q \Rightarrow r}{p \Rightarrow r}$$

Now, the implication $[(p \Rightarrow q) \wedge (q \Rightarrow r)] \Rightarrow (p \Rightarrow r)$ is always true as shown in the truth table below.

p	q	r	$p \Rightarrow q$	$q \Rightarrow r$	$p \Rightarrow r$	$(p \Rightarrow q) \wedge (q \Rightarrow r)$	$[(p \Rightarrow q) \wedge (q \Rightarrow r)] \Rightarrow (p \Rightarrow r)$
T	T	T	T	T	T	T	T
T	T	F	T	F	F	F	T
T	F	T	F	T	T	F	T
T	F	F	F	T	F	F	T
F	T	T	T	T	T	T	T
F	T	F	T	F	T	F	T
F	F	T	T	T	T	T	T
F	F	F	T	T	T	T	T

Therefore, the argument $p \Rightarrow q, q \Rightarrow r \vdash p \Rightarrow r$ is valid.

The construction of such a big truth table may be avoided by studying and correctly applying the following rules by which we check whether a given argument is valid or not. They are called **rules of inference** and are listed as follows.

1	$\frac{p}{p \vee q}$	Principle of adjunction addition . It states that "If p is true, then $p \vee q$ is also true for any proposition q "
2	$\frac{p \wedge q}{p}$	Principle of detachment simplification . It states that "If $p \wedge q$ is true, then p is true".
3	$\frac{q}{p \wedge q}$	Principle of conjunction . It states that whenever p and q are true the statement $p \wedge q$ is also true.
4	$\frac{p}{q}$	Modus ponens . It states that whenever the implication $p \Rightarrow q$ is true and the hypothesis p is true, then the consequent q is also true. Recall the rule of implication.
5	$\frac{\neg q}{\neg p}$	Modus Tollens . It states that whenever, $p \Rightarrow q$ is true and q is false, then p is also false.
6	$\frac{q \Rightarrow r}{p \Rightarrow r}$	Principle of sylogism (Law of sylogism). It may be remembered as the transitive property of implication. This law was one of Aristotle's (384 – 322 B.C.) main contributions to logic.
7	$\frac{\neg p}{q}$	Modus Tollends Ponens . This rule is also called the Disjunctive sylogism .

Let us now consider examples that show how the above rules of inference are applied.

Example 6 Identify the rule of inference applied for each of the following arguments.

a It is raining.

Therefore, it is raining or it is cold.

The rule that applies to this argument is rule 1 (adjunction).

- b** Abdissa is rich and happy.
Therefore, he is rich.
The rule applied here is rule 2 (Detachment).
- c** It is cold today.
It is raining today.
Therefore, it is raining and it is cold today.
This argument uses rule 3 (conjunction).
- d** If Hanna works hard, then she will score good grades. Hanna works hard.
Therefore Hanna scores good grades.
This argument uses rule 4 (Modus ponens).
- e** If it is raining, then I get wet when I go outside. I do not get wet when I go outside.
Therefore, it is not raining.
In this argument, the appropriate rule is rule 5 (Modus Tollens).
- f** If I get a job, then I will earn money.
If I earn money, then I will buy a computer.
Therefore, if I get a job, then I will buy a computer.
The inference rule 6 (Principle of syllogism) is applied here.
- g** Either wages are low or prices are high .Wages are not low.
Therefore, prices are high.
The inference rule applied here is rule 7. (Modus Tollends Ponens)

Example 7 Using rules of inference, check the validity of the following argument.

$$\begin{array}{l}
 p \\
 p \Rightarrow q \\
 \underline{q \Rightarrow r} \\
 r
 \end{array}$$

Solution

- 1** p is true (premise)
 - 2** $p \Rightarrow q$ is true (premise)
 - 3** q is true (Modus ponens from 1, 2)
 - 4** $q \Rightarrow r$ is true (premise)
 - 5** r is true (Modus ponens from 3, 4)
- Therefore, the argument is valid. i.e., $p, p \Rightarrow q, q \Rightarrow r \vdash r$ is valid.

Note:

This is not the only way you can show this. Here is another set of steps.

- 1 p is true (premise).
 - 2 $p \Rightarrow q$ is true (premise).
 - 3 $q \Rightarrow r$ is true (premise).
 - 4 $p \Rightarrow r$ is true (syllogism from 2,3).
 - 5 r is true (Modus ponens from 1, 4).
- Therefore, the argument is valid.

All the examples considered above are examples of valid arguments. It is now time to see an example of an invalid argument (or a fallacy).

$$\text{Example 8} \quad \frac{q \quad \neg p \Rightarrow \neg q}{\neg p}$$

Solution

- 1 q is true (premise)
 - 2 $\neg q$ is false from (1)
 - 3 $\neg p \Rightarrow \neg q$ is true (premise)
 - 4 $\neg p$ is false (from 2 and 3)
- Therefore, the argument form is not valid.

Exercise 7.2

- 1 Which of the following are statements? Which of them are open statements?

a Plato was a philosopher.	b $\sqrt{3}$ is rational
c $x^2 + 1 = 5$	d $(\exists x)(x^2 + 1 = 5)$
e What is today's date?	
- 2 Let $p: 5 + 3 = 9$ and $q: \text{Today is sunny}$
 - a** Write each of the following in symbolic form
 - i** $5 + 3 = 9$ or today is not sunny
 - ii** $5 + 3 = 9$ only if today is sunny
 - iii** $5 + 3 \neq 9$ if and only if today is sunny
 - iv** It is sufficient that today is sunny in order that $5 + 3 \neq 9$.
 - b** Write each of the following in words.

i $p \wedge \neg q$	ii $\neg p \Rightarrow q$	iii $(p \vee q) \Rightarrow \neg q$
----------------------------	----------------------------------	--

- 3** Using truth tables, show that each pair of the following are equivalent.
- a** $\neg p \vee q ; \neg q \Rightarrow \neg p$ **b** $\neg p \Leftrightarrow \neg q ; p \Leftrightarrow q$
- c** $\neg p \Leftrightarrow q ; (p \vee q) \wedge \neg(p \wedge q)$
- 4** Using truth tables, check whether each of the following arguments given symbolically is valid or invalid (a fallacy).
- a**
$$\frac{p \qquad q}{p \Rightarrow q}$$
 b
$$\frac{p \qquad \neg q}{q \Rightarrow p}$$
 c
$$\frac{p \wedge q \qquad p \Rightarrow q}{p \vee q}$$
- 5** For each of the following arguments written in words determine whether the argument is valid or not.
- a** Your troubles start when you get married.
You have no troubles.
Therefore, you are not married.
- b** If Legesse drinks beer, he is at least 18 years old.
Legesse does not drink beer.
Therefore, Legesse is not yet 18 years old.
- 6** Using rules of inference check the validity of each of the following arguments.
- $p \Rightarrow (q \vee r)$
- a**
$$\frac{\neg q \wedge \neg r}{\neg p}$$
- b** If I study, then I will not fail in mathematics.
If I do not watch TV frequently, then I will study. But, I failed in mathematics.
Therefore, I must have watched TV frequently.
- 7** Using truth tables, check the validity of each of the following arguments.
- a**
$$\frac{p \wedge \neg q \qquad r \vee \neg p}{q \Rightarrow r}$$
 b
$$\frac{p \wedge \neg q \qquad \neg q}{p}$$
 c
$$\frac{p \vee \neg r \qquad p \vee q}{q \vee r}$$
- 8** Using rules of inference check the validity of each of the following.
- a** $p \Rightarrow \neg q , r \Rightarrow q , r \vdash \neg p$
- b** Hailu's books are on the desk or on the shelf.
The books are not on the shelf.
Therefore, they are on the desk.
- c** If 5 is even, then 2 is prime. 2 is prime if and only if 4 is positive.
4 is not positive.
Therefore, 5 is not even.

7.2 DIFFERENT TYPES OF PROOFS

In Mathematics, a proof of a given statement is a sequence of statements that form an argument. When a valid argument is constructed, you say that the given statement is proved. There are different methods by which proofs are constructed. The rules of inference discussed above, are instruments to construct proofs. In this section, you shall consider different types of proofs of mathematical statements.

Since many mathematical statements are implications, the techniques for proving implications are important. Recall that the implication $p \Rightarrow q$ is true unless p is true and q is false. Therefore, you notice that when the statement $p \Rightarrow q$ is proved, the only thing to be shown is that q is true if p is true; it is not usually the case that q is proved to be true, in isolation. The following discussion will give you the most common techniques for proving implications.

Direct proof

The implication $p \Rightarrow q$ can be proved by showing that if p is true, then q must also be true. A proof of this kind is called a **direct proof**. To construct such a proof, you assume that p is true and use rules of inference and facts already known or proved, to show that q must also be true.

ACTIVITY 7.4



- 1** Complete the proof of the following statement.
If x and y are odd integers, then $x + y$ is an even integer.

Proof:

If x and y are odd integers, then there exist integers m and n such that
 $x = 2n + 1$ and $y = 2m + 1$.

$$\Rightarrow x + y = \underline{\hspace{2cm}}$$

$$\vdots$$

Therefore, $x + y$ is an even integer.

- 2** Given below is a proof of the following statement. Give reasons why each of the statements in the proof is true.

$$\forall n, m \in \mathbb{R}, \text{ if } n > m > 0, \text{ then } \frac{m+5}{n+5} > \frac{m}{n}.$$

Proof:

$$n > m \Rightarrow 5n > 5m \Rightarrow 5n + mn > 5m + mn \Rightarrow n(m+5) > m(n+5)$$

$$\Rightarrow \frac{m+5}{n+5} > \frac{m}{n}$$

Example 1 Give a direct proof of the statement "If n is odd, then n^2 is odd".

Proof:

Assume that the hypothesis of the statement (implication) is true; i.e. suppose that n is odd. Then $n = 2k+1$ for some integer k .

Then, it follows that $n^2 = (2k + 1)^2 = 4k^2 + 4k + 1 = 2(2k^2 + 2k) + 1 = 2m + 1$ (where $m = 2k^2 + 2k$ which is an integer).

Therefore, n^2 is odd (as it is 1 more than an even integer).

The method of cases or exhaustion

In this method, each and every possible case is considered.

Example 2 Show that $n^2 + 3n + 7$ is odd for all $n \in \mathbb{Z}$

Proof:

Case 1 n is even

n is even $\Rightarrow n = 2k$, for $k \in \mathbb{Z}$, by definition.

$$\Rightarrow n^2 + 3n + 7 = (2k)^2 + 3(2k) + 7 = 4k^2 + 6k + 7 = 2(2k^2 + 3k + 3) + 1$$

Hence, $n^2 + 3n + 7$ is odd.

Case 2 n is odd

n is odd $\Rightarrow n = 2k + 1$, for some $k \in \mathbb{Z}$

$$\begin{aligned} \text{Accordingly } n^2 + 3n + 7 &= (2k + 1)^2 + 3(2k + 1) + 7 = 4k^2 + 4k + 1 + 6k + 3 + 7 \\ &= 2(2k^2 + 5k + 5) + 1 \end{aligned}$$

Thus, $n^2 + 3n + 7$ is odd

\therefore From cases 1 and 2, $n^2 + 3n + 7$ is odd $\forall n \in \mathbb{Z}$.

Example 3 Show that for any $x, y \in \mathbb{R}$, the maximum of x and y is given by

$$\frac{x + y + |x - y|}{2}.$$

Proof:

Two cases arise: Either $x \geq y$ or $x < y$

Case 1 $x \geq y$

$$x \geq y \Rightarrow x - y \geq 0$$

Then the maximum of x and y is x and $|x - y| = x - y$ by definition of absolute value.

$$\text{Now, } \frac{x + y + |x - y|}{2} = \frac{x + y + (x - y)}{2} = \frac{2x}{2} = x$$

Hence the maximum of x and y is $\frac{x + y + |x - y|}{2} = x$

Case 2 $x < y$

$$x < y \Rightarrow x - y < 0 \Rightarrow \text{maximum of } x \text{ and } y \text{ is } y \text{ and } |x - y| = -(x - y) = -x + y.$$

$$\text{Here, } \frac{x + y + |x - y|}{2} = \frac{x + y - (x - y)}{2} = \frac{2y}{2} = y$$

$$\text{So the maximum of } x \text{ and } y \text{ is } \frac{x + y + |x - y|}{2} = y$$

$$\therefore \text{The maximum of } x \text{ and } y \text{ is } x \text{ or } y \text{ given by } \frac{x + y + |x - y|}{2}.$$

Indirect proof

Since the implication $p \Rightarrow q$ is equivalent to its contrapositive $\neg q \Rightarrow \neg p$, the implication $p \Rightarrow q$ can be proved by proving its contrapositive, $\neg q \Rightarrow \neg p$, is a true statement. A proof that uses this technique is called an **indirect proof**.

Example 4 Prove the statement "If $5n + 2$ is odd, then n is odd".

Proof:

Assume that the conclusion of the implication is false; i.e. suppose n is even. Then, $n = 2k$ for some integer k . It follows that

$$5n + 2 = 5(2k) + 2 = 10k + 2 = 2(5k + 1).$$

So $5n + 2$ is even (as it is a multiple of 2).

Thus, you have shown that if n is even, then $5n + 2$ is even. You showed that the negation of the conclusion implies the negation of the hypothesis. Therefore, its contrapositive, which says "if $5n + 2$ is odd, then n is odd" is true.

This ends the proof.

Remark:

In **Example 1**, the statement that "if n is odd, then n^2 is odd" is proved. Using the method of **Example 5**, we have equally proved that the statement "If n^2 is even, then n is even" is also true, because this statement is the contrapositive of the above one.

Example 5 Show that $\forall x, y \in \mathbb{R}$, with x and y positive,

$$\text{if } xy > 25 \text{ then } x > 5 \text{ or } y > 5.$$

Proof:

You can use indirect proof.

Suppose, $0 < x \leq 5$ and $0 < y \leq 5$. Then, $0(0) < xy \leq 5(5)$. i.e., $0 < xy \leq 25$.

Thus, the product xy is not larger than 25.

\therefore If $xy > 25$, then $x > 5$ or $y > 5$ by a contra positive.

Proof by contradiction

In the previous methods of proof, you used the method of proof that assumes p is true and finally concludes that q is also true. Now what will happen if you start by assuming the implication $p \Rightarrow q$ is false? That means, if p is true and q is false? If this assumption leads to a conclusion which contradicts either one of the assumptions or conclusions or any previously known fact, then the assumption $p \Rightarrow q$ is false was not correct. This will tell you that $p \Rightarrow q$ is always true. This method of argument is known as **proof by contradiction**.

Example 6 Prove the following statement by using the method of proof by contradiction. " $\sqrt{2}$ is an irrational number".

Proof:

Let p be the statement " $\sqrt{2}$ is an irrational number". Suppose that $\neg p$ is true. Then, $\sqrt{2}$ is a rational number. We shall now show that this leads to a contradiction. The assumption that $\sqrt{2}$ is rational implies that there exist integers a and b such that $\sqrt{2} = \frac{a}{b}$, where a and b have no common factor other than ± 1 (so that $\frac{a}{b}$ is in its lowest terms). Since $\sqrt{2} = \frac{a}{b}$, by squaring both sides you get

$$2 = \frac{a^2}{b^2} \Rightarrow a^2 = 2b^2.$$

This means that a^2 is even implying that a is even. Now, since a is even, it follows that $a = 2c$ for some integer c .

Thus, $2b^2 = a^2 = 4c^2 \Rightarrow b^2 = 2c^2$.

This again means that b^2 is even, hence b is even as well. Hence 2 is a common factor of a and b .

Notice that it has been shown that $\neg p$ implies that $(r \wedge \neg r)$ is true. Note that as shown above, from $\neg p$, $\sqrt{2} = \frac{a}{b}$ is rational, a and b have no common factor other than ± 1 , and at the same time 2 divides both a and b , i.e 2 is a common factor of a and b .

This is a contradiction, since you have shown that $\neg p$ implies both r and $\neg r$ where r is the statement " a and b are integers with no common factor other than ± 1 ".

Hence $\neg p$ is false, as a result, p : " $\sqrt{2}$ is an irrational number" is true.

Example 7 Show that the sum of a rational and an irrational number is an irrational number.

Proof:

Let a be a rational and b be an irrational number.

Suppose that on the contrary $a + b$ is rational.

Then, $a = \frac{p}{q}$ and $a + b = \frac{r}{s}$ for some $p, q, r, s \in \mathbb{Z}, q, s \neq 0$.

Now, $a + b = \frac{p}{q} + b = \frac{r}{s} \Rightarrow b = \frac{r}{s} - \frac{p}{q} = \frac{qr - ps}{sq}$
 $\Rightarrow b$ is rational ($qr - ps \in \mathbb{Z}$ and $sq \in \mathbb{Z}, sq \neq 0$)

This contradicts the assumption that b is irrational.

Thus, if a is rational and b is irrational, then $a + b$ is irrational.

Disproving by counter-example

ACTIVITY 7.5



Give the negation of each of the following statements in symbolic form.

- 1 $(\forall x) (x^2 > 0, \text{ where } x \text{ is a real number})$
- 2 $(\exists x) (2x \text{ is a prime number, where } x \text{ is a natural number})$
- 3 $((\forall x) (\exists y) (x = y^2 + 1, \text{ where } x \text{ and } y \text{ are real numbers}))$

Note:

From Activity 7.5, you have the following results:

- 1 $\neg(\forall x) (P(x)) = (\exists x) (\neg P(x))$
- 2 $\neg(\exists x) (Q(x)) = (\forall x) (\neg Q(x))$

Suppose that you want to show that a statement of the form $(\forall x) P(x)$ is not true. This is done by producing an element x_0 from the universal set that makes $P(x)$ false when substituted in place of x . Such an element x_0 is called a counterexample.

Note that only one counterexample needs to be found to show that $(\forall x) P(x)$ is false.

Example 8 Disprove the statement:

"For every natural number n , $n^2 - 11n + 121$ is prime"

Proof:

It is sufficient to find one natural number that does not satisfy this condition. Thus, if you take $n = 5$, you see that $5^2 - 11(5) + 121 = 91$. But 91 is not a prime number as 7 divides 91 i.e. $91 \div 7 = 13$.

Therefore, the statement " $\forall n \in \mathbb{N}, n^2 - 11n + 121$ is prime" is now disproved using the counter example $n = 5$.

The different methods of proofs discussed above are not an exhaustive list of methods of proof. They are just the most common methods and it is hoped that they will help you see how the ideas of mathematical logic can be applied in stating and proving theorems.

Exercise 7.3

- 1 Prove that the sum of two consecutive odd integers is a multiple of 4.
- 2 Show that, if a and b are rational numbers with $a < b$, then there exists a rational number c such that $a < c < b$.
- 3 Prove that for any real numbers a and b , $a + b \geq 40$, if and only if $a \geq 20$ or $b \geq 20$.
- 4 Prove that the square of any integer is of the form $3k$ or $3k + 1$, for $k \in \mathbb{Z}$.
- 5 If $m, n \in \mathbb{N}$ and mn is not a perfect square, then m is not a perfect square or n is not a perfect square. ($x \in \mathbb{N}$ is a perfect square, if $\exists n \in \mathbb{N}$ such that $x = n^2$)
- 6 Show that $\sqrt{5}$ is irrational.
- 7 Show that if x and y are positive, then $\sqrt{x^2 + y^2} \neq x + y$.
- 8 Check whether or not each of the following is true.
 - a For any sets A and B , $A \cap B \subseteq A \cup B$
 - b For any $n \in \mathbb{N}$, n is even implies that $2^n - 1$ is not prime.
- 9 Prove or disprove each of the following statements
 - a If x and y are even integers, then xy is also even.
 - b If $3n + 2$ is odd, then n is odd.
 - c $\forall n \in \mathbb{N}, n! < n^3$
 - d $\forall n \in \mathbb{N}, n^2 < n^3$

7.3 PRINCIPLE AND APPLICATION OF MATHEMATICAL INDUCTION

Before we state the **principle of mathematical induction**, let us consider some examples.

Example 1 Consider the sum of the first n odd positive integers. That is,

$$\begin{array}{lll}
 \text{if } n = 1, & 1 = 1 & = 1^2 \\
 \text{if } n = 2, & 1 + 3 = 4 & = 2^2 \\
 \text{if } n = 3, & 1 + 3 + 5 = 9 & = 3^2 \\
 \text{if } n = 4, & 1 + 3 + 5 + 7 = 16 & = 4^2 \\
 \text{if } n = 5, & 1 + 3 + 5 + 7 + 9 = 25 & = 5^2 \\
 \text{if } n = 6, & 1 + 3 + 5 + 7 + 9 + 11 = 36 & = 6^2
 \end{array}$$

From the results above, it looks as if the sum of the first n odd natural numbers is always given by n^2 . To express this idea symbolically, first observe that the n^{th} odd natural number is given by $2n - 1$, (which you may check yourself). Then what we have derived above can be expressed as:

$$1 + 3 + 5 + 7 + 9 + \dots + (2n - 1) = n^2 \quad (*)$$

You have seen by direct calculation that the formula (*) is true when n has any one of the values 1, 2, 3, 4, 5 and 6.

Does this mean that the formula (*) is true for any natural number n ? Can we be sure of this simply by continuing numerical calculations?

Try the case when $n = 13$. Direct calculation shows that:

$$1 + 3 + 5 + 7 + 9 + 11 + 13 + 15 + 17 + 19 + 21 + 23 + 25 = 169 = 13^2.$$

So, our formula (*) seems to hold. One might also be tempted to say that since the natural number $n = 13$ is chosen randomly, this proves that (*) is true for every possible choice of n . Actually, no matter how many cases you check, you can never prove that (*) is always true, because there are infinitely many cases and no amount of pure calculation can check them all.

So, what is needed is some logical argument that will prove that formula (*) is true for every natural number n .

Before you consider the details of this logical argument, some examples of assertions which can be checked by direct calculation for small values of n , but which after careful investigation, turn out to be false for some other values of n .

Example 2 Consider the number P which is expressed in the form

$$P = 2^{2^n} + 1 \dots\dots\dots \mathbf{i}$$

Where n is a non-negative integer, then by direct calculation, we observe that

when $n = 0$,	$P = 2^1 + 1 = 3$
when $n = 1$,	$P = 2^2 + 1 = 5$
when $n = 2$,	$P = 2^4 + 1 = 17$
when $n = 3$,	$P = 2^8 + 1 = 257$
when $n = 4$,	$P = 2^{16} + 1 = 65,537$

Each of these values of P is a prime number. Based on these results, can you conclude that P is always a prime number for every whole number n ? Of course not. You might guess that this is true but we should not make a positive assertion unless you can supply a proof that is valid for every whole number n ; because when $n = 5$, the number P is found not to be prime since:

$$P = 2^{32} + 1 = 4,294,967,297 = 641 \times 6,700,417, \text{ which is not prime.}$$

Example 3 Consider the inequality below, where n is a natural number.

$$2^n < n^{10} + 2 \dots\dots\dots \text{ii}$$

If we calculate both sides of (ii) for the first four values of n , you observe that

- when $n = 1$, you get $2 < 1 + 2 = 3$
- when $n = 2$, you get $4 < 1024 + 2 = 1026$
- when $n = 3$, you get $8 < 59,051$
- when $n = 4$, you get $16 < 1,048,578$

It certainly appears as if the inequality is true for any natural number n . If you also try for a larger value of n , say $n = 20$, then the inequality ii shows that

$$1,048,576 < 10,240,000,000,002$$

which is obviously true. But, even this does not prove that the inequality ii is always true. This assertion is actually false, because when $n = 59$, you find (approximately) that $2^{59} = 5.764 \times 10^{17}$ while $59^{10} + 2 = 5.111 \times 10^{17}$

The last two examples show that you cannot conclude that an assertion involving an integer n is true for all positive values of n just by checking specific values of n , no matter how many you check.

How then is such an assertion proved to be true?

An assertion involving a natural number can be proved by using a method known as the Principle of Mathematical Induction, stated as follows.



HISTORICAL NOTE

Augustus Demorgan (1806 - 1871)

One of the techniques to prove mathematical statements discussed in this unit is the Principle of Mathematical Induction. Even though the method was used by Fermat, Pascal and others before him, the actual term mathematical induction was first used by Demorgan. The method is used in many branches of higher mathematics.



Principle of Mathematical Induction

For a given assertion involving a natural number n , if

- i** the assertion is true for $n = 1$
- ii** it is true for $n = k + 1$, whenever it is true for $n = k$ ($k \geq 1$),

then the assertion is true for every natural number n .

Let us now illustrate the use of this principle by considering different examples. Your first example will be the one which you considered at the beginning of this section.

Example 4 Show that the sum of the first n odd natural numbers is given by n^2 . i.e., show that,

$$1 + 3 + 5 + \dots + (2n - 1) = n^2 \dots\dots\dots *$$

for every natural number n .

Proof:

1 It is clear that $*$ is true when $n = 1$ because $1 = 1^2$.

2 Now assume that $*$ is true for $n = k$; that is assume that

$$1 + 3 + 5 + \dots + (2k - 1) = k^2 \dots\dots\dots **$$

To obtain the sum of the first $k + 1$ odd integers, you simply add the next odd integer which is $2k + 1$, to both sides of $**$ to get:

$$1 + 3 + 5 + \dots + (2k - 1) + (2k + 1) = k^2 + (2k + 1) = (k + 1)^2$$

This is the same as $*$ replacing n with $k + 1$. Hence, you have shown that if the assertion is true for k , it is also true for $k + 1$.

By the principle of Mathematical Induction, this completes the proof that $*$ is true for any natural number n .

Example 5 Show that the equation

$$1 + 4 + 7 + 10 + \dots + (3n - 2) = \frac{n(3n - 1)}{2} \dots\dots\dots \text{i}$$

is true for any natural number n .

Proof:

1 The equation **i** is true for $n = 1$ because $1 = \frac{1(3(1) - 1)}{2} = \frac{1 \times 2}{2}$

2 Assume that the equation **i** is true for $n = k$; that is you assume that,

$$1 + 4 + 7 + 10 + \dots + (3k - 2) = \frac{k(3k - 1)}{2} \dots\dots\dots \text{ii}$$

Now, if you add the next addend which is $3(k + 1) - 2$ or $3k + 1$ to both sides of **ii**, you get:

$$\begin{aligned} 1 + 4 + 7 + 10 + \dots + (3k - 2) + (3k + 1) &= \frac{k(3k - 1)}{2} + (3k + 1) \\ &= \frac{k(3k - 1) + 2(3k + 1)}{2} = \frac{3k^2 + 5k + 2}{2} = \frac{(k + 1)(3k + 2)}{2} = \frac{(k + 1)(3(k + 1) - 1)}{2} \end{aligned}$$

But this last equation is the equation **i** itself when n is replaced by $k + 1$. Hence you have shown that if the equation is true for k , it is also true for $k + 1$. By the principle of **Mathematical Induction**, this completes the proof that equation **i** is true for any natural number n .

Example 6 Prove that for any natural number n , $n < 2^n$.

Proof:

1 First for $n = 1$, $1 < 2^1 = 2$ is true

2 Assume that $n < 2^n$ is true for $n \geq 1$.

Now you need to show it is true also for $n + 1$; that is $n + 1 < 2^{n+1}$ is also true.

Adding 1 on both sides of $n < 2^n$, you get

$$n + 1 < 2^n + 1$$

Again because $1 \leq 2^n$ for any non-negative integer n , you get:

$$n + 1 < 2^n + 1 \leq 2^n + 2^n = 2(2^n) = 2^{n+1}.$$

Thus, $n + 1 < 2^{n+1}$

That means whenever $n < 2^n$ is true, $n + 1 < 2^{n+1}$ is also true. In other words, whenever your assertion is true for a natural number n , it is also true for $n + 1$.

Therefore, by the principle of mathematical induction, the assertion $n < 2^n$ is true for any natural number n .

Example 7 Use Mathematical Induction to prove that $n^3 - n$ is divisible by 3.

Proof:

1 The assertion is true when $n = 1$ because $1^3 - 1 = 0$ and 0 is divisible by 3.

2 For $n = k \geq 1$, assume that $k^3 - k$ is divisible by 3 is true for a natural number k and you must show that this is also true for $n = k + 1$. That means you have to show that $(k + 1)^3 - (k + 1)$ is divisible by 3.

Now, observe that

$$\begin{aligned} (k + 1)^3 - (k + 1) &= (k^3 + 3k^2 + 3k + 1) - (k + 1) \text{ (expanding } (k + 1)^3 \text{)} \\ &= (k^3 - k) + (3k^2 + 3k) = (k^3 - k) + 3(k^2 + k) \end{aligned}$$

Since by the assumption $k^3 - k$ is divisible by 3 and $3(k^2 + k)$ is clearly divisible by 3, (as it is 3 times some integer), you notice that the sum $(k^3 - k) + 3(k^2 + k)$ is divisible by 3. Thus, it follows that $(k + 1)^3 - (k + 1)$ is divisible by 3. Therefore, by the principle of mathematical induction, $k^3 - k$ is divisible by 3 for any natural number k .

Exercise 7.4

- 1 Show that $1 + 2 + 3 + \dots + n = \frac{n(n+1)}{2}$, for each natural number n .
- 2 Show that $2 + 4 + 6 + \dots + 2n = n(n+1)$ for each natural number n .
- 3 Find $2 + 4 + 6 + \dots + 100$.
- 4 You may now answer **Questions c** and **d** of the opening problem of this unit. Please try them.
- 5 A set of boxes are put on top of each other. The upper most row has 6 boxes, the one below it has 8 boxes, and the next lower rows has 10 boxes and so on. If there are n rows and $4n + 110$ boxes all in all, find the value of n .
- 6 Prove that the n^{th} even natural number is given by $2n$.
- 7 Prove that the n^{th} odd natural number is given by $2n - 1$.
- 8 Show that $6^n - 1$ is a multiple of 5. $\forall n \in \mathbb{N}$
- 9 Show that $2^{n-1} \leq n!$ $\forall n \in \mathbb{N}$
- 10 Show that for all $n \in \mathbb{N}$, $1^3 + 2^3 + \dots + n^3 = \frac{n^2(n+1)^2}{4}$, $n \in \mathbb{N}$.



Key Terms

argument	mathematical induction
bi-implication	method of cases (exhaustion)
conclusion	negation
conjunction	open statement
connective	premise
counter example	proof by contradiction
direct proof	rules of inference
disjunction	statement (proposition)
existential quantifier	universal quantifier
implication	validity
indirect proof (contra positive)	



Summary

1 Rules of connectives: For propositions p and q ,

p	q	$\neg p$	$p \wedge q$	$p \vee q$	$p \Rightarrow q$	$p \Leftrightarrow q$
T	T	F	T	T	T	T
T	F	F	F	T	F	F
F	T	T	F	T	T	F
F	F	T	F	F	T	T

2 **Universal quantifier:**

$\forall x$ means for each x , for any x , for every x or for all x .

3 **Existential quantifier:**

$\exists x$ means for some x or there exists x .

4 $(\forall x)(P(x) \Rightarrow Q(x))$: Every $P(x)$ is $Q(x)$

5 $(\exists x)(P(x) \wedge Q(x))$: Some $P(x)$ is $Q(x)$ and some $Q(x)$ is $P(x)$

6 $\neg(\forall x)P(x) \equiv (\exists x)\neg P(x)$

7 $\neg(\exists x)P(x) \equiv (\forall x)\neg P(x)$

8 An argument is an assertion that a given set of statements called **premises** yield another statement called a **conclusion**.

9 An argument is **valid**, if whenever all the premises are true, the conclusion is also true. Otherwise it is called a **fallacy**.

10 An argument is valid, if and only if the conjunction of all premises always implies the conclusion.

11 **Rules of Inference:**

a $\frac{p}{p \vee q}$ (Addition)

p

c $\frac{q}{p \wedge q}$ (conjunction)

$p \Rightarrow q$

e $\frac{\neg q}{\neg p}$ (Modus Tollens)

b $\frac{p \wedge q}{p}$ (Simplification)

$p \Rightarrow q$

d $\frac{p}{q}$ (Modus ponens)

$p \Rightarrow q$

f $\frac{q \Rightarrow r}{p \Rightarrow r}$ (syllogism)

$$p \vee q$$

$$\mathbf{g} \quad \frac{\neg p}{q} \text{ (disjunctive syllogism)}$$

12 Direct proof:

Given a statement of the form $p \Rightarrow q$, proving it using steps

$$p$$

$$p_1$$

$$p_2$$

$$\vdots$$

$$\frac{p_n}{q}$$

where p_1, p_2, \dots, p_n are previously established theorems, definitions, postulates etc, is called a **direct proof**.

13 Method of cases:

When one proves an assertion by considering all possible cases, the proof is done by method of cases (**exhaustion**).

14 Indirect (contra positive) proof

To prove $p \Rightarrow q$ you can prove its contra positive $\neg q \Rightarrow \neg p$.

15 Proof by contradiction

To show that p is true, you seek for an assertion r such that $\neg p \Rightarrow (r \wedge \neg r)$ is true.

16 Disproving by counter example

To show that $(\forall x)P(x)$ is false, you seek an object x_0 from the universe of $P(x_0)$ such that $P(x_0)$ is false (called a **counter example**).

17 Principle of mathematical induction

If for a given assertion involving a natural number n , you can show that

- i** the assertion is true for $n = 1$.
- ii** if it is true for $n = k$, then it is also true for $n = k + 1$;

then the assertion is true for every natural number n .

$$\begin{array}{ccc} p \Rightarrow q & p \Rightarrow q & p \vee q \\ \mathbf{d} \quad \frac{\neg p}{\neg q} & \mathbf{e} \quad \frac{r \Rightarrow q}{p \Rightarrow r} & \mathbf{f} \quad \frac{p}{\neg q} \end{array}$$

- 8** Check the validity of each of the following arguments given verbally.
- a** If you send me an email message, then I will finish my homework.
If you do not send me an email message, then I will go to sleep early.
If I go to sleep early, then I will wake up early.
Therefore, if I do not finish my homework, then I will wake up early.
- b** If Alemu has an electric car and he drives a long distance, then his car will need to be recharged. If his car needs to be recharged, then he will visit an electric station.
Alemu drives a long distance. However, he will not visit an electric station.
Therefore, Alemu does not have an electric car.
- 9** Prove or disprove each of the following statements.
- a** If x and y are odd integers, then xy is an odd integer.
- b** The product of two rational numbers is always a rational number.
- c** The product of two irrational numbers is always an irrational number.
- d** The sum of two rational numbers is always a rational number.
- e** If n is an integer and $n^3 + 5$ is odd, then n is even.
- f** For every prime number k , $k + 2$ is prime.
- g** For real numbers p and q , if $\sqrt{pq} \neq \frac{p+q}{2}$, then $p \neq q$.
- h** $\forall n, r \in \mathbb{Z}$ and $n \geq r \geq 2$, $\binom{n}{r} = \binom{n}{n-r}$
- 10** Prove each of the following statements by the method of **Mathematical Induction**, for all natural numbers n .
- a** $1 + 2 + 2^2 + \dots + 2^n = \sum_{k=0}^n 2^k = 2^{n+1} - 1$
- b** $1^2 + 2^2 + 3^2 + 4^2 + \dots + n^2 = \frac{n(n+1)(2n+1)}{6}$
- c** $(1 \times 2) + (2 \times 3) + (3 \times 4) + \dots + n(n+1) = \frac{n(n+1)(n+2)}{3}$
- d** $1^2 + 3^2 + 5^2 + \dots + (2n-1)^2 = \frac{n(2n-1)(2n+1)}{3}$
- e** $\frac{1}{1 \times 2} + \frac{1}{2 \times 3} + \frac{1}{3 \times 4} + \dots + \frac{1}{n(n+1)} = \frac{n}{n+1}$

Unit 8

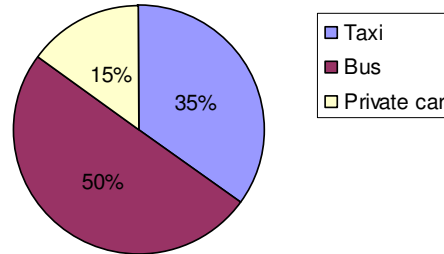

FURTHER ON STATISTICS

Unit Outcomes:

After completing this unit, you should be able to:

- *know basic concepts about sampling techniques.*
- *construct and interpret statistical graphs.*
- *know specific facts about measurement in statistical data.*

Main Contents

8.1 SAMPLING TECHNIQUES

8.2 REPRESENTATION OF DATA

8.3 CONSTRUCTION OF GRAPHS AND INTERPRETATION

8.4 MEASURES OF CENTRAL TENDENCY AND MEASURES OF VARIABILITY

8.5 ANALYSIS OF FREQUENCY DISTRIBUTIONS

8.6 USE OF CUMULATIVE FREQUENCY CURVES

Key terms

Summary

Review Exercises

INTRODUCTION

In **Grade 9** and **Grade 11**, you did some work in statistics, including collection and tabulation of statistical data, frequency distributions and histograms, measures of location (mean, median and mode(s), quartiles, deciles and percentiles), measures of dispersion for both ungrouped and grouped data, and some ideas of probability. In this unit, you will study descriptive statistics.

8.1 SAMPLING TECHNIQUES

ACTIVITY 8.1



The Ministry of Agriculture and Natural Resources wants to study the productivity benefits of using irrigation farming.

If you were asked to study this, obviously you would start by collecting data. Discuss the following questions.

- 1 Why do you need to collect data?
- 2 How would you collect the data?
- 3 From where would you collect the data?

Statistics as a science deals with the proper collection, organization, presentation, analysis and interpretation of numerical data. Since statistics is useful for making decisions or forecasting future events, it is applicable in almost all sciences. It is useful in social, economic and political activities. It is also useful in scientific investigations. Some examples of applications of statistics are given below.

1 Statistics in business

Statistics is widely used in business to make business forecasts. A successful business must keep a proper record of information in order to predict the future course of the business, and should be accurate in statistical and business forecasting. Statistics can also be used to help in formulating economic policies and evaluating their effect.

2 Statistics in meteorology

Meteorologists forecast weather for future days based on information they obtain from different sources. Hence their forecasts are based on statistics that have been collected.

3 Statistics in schools

In schools, teachers rank their students at the end of a semester based on information collected through different methods (exams, tests, quizzes, etc.) which gives an indication of the students' performance.

Note:

- 1 Collection of data is the basis for any statistical analysis. Great care must be taken at this stage to get accurate data. Inaccurate and inadequate data may lead to wrong or misleading conclusions and cause poor decisions to be made.
- 2 Recall that a **population** in statistics means the complete collection of items (individuals) under consideration.

It is often impractical and too costly to collect data from the whole population or make census survey. Consequently, it is frequently necessary to use the process of sampling, from which conclusions are drawn about a whole population. This leads you into an essential statistical concept called **sampling** which is important for practical purposes.

A **sample** is a limited number of items taken from a population which is being studied/ investigated.

A sample needs to be taken in such a way that it is a true representation of the population. It should not be biased so as to cause a wrong conclusion. Avoiding bias requires the use of proper sampling techniques. Before examining sampling techniques, you need to note the following.

During sampling, the following points must be considered.

- 1 **Size of a sample:** There is no single rule for determining the size of a sample of a given population. However, the size should be adequate in order to represent the population.
To get an adequate size, you check
 - i **Homogeneity or heterogeneity of the population:** If the population has a homogeneous nature, a smaller size sample is sufficient. (For example, a drop of blood is sufficient to take a blood test from someone) .
 - ii **Availability of resources:** If sufficient resources are available, it is advisable to increase the size of the sample.
- 2 **Independence:** Each item or individual in the population should have an equal chance of being selected as a member of the sample.

Techniques of sampling

ACTIVITY 8.2

The Athletics Federation decides to construct an athletics academy in some part of Ethiopia. For this purpose, it needs to study the potential source of athletes so as to decide where to build the facility.



- 1 Is it possible to study the whole population of the country? Why?

- 2** How would the Federation collect a sample from the entire population?
3 What characteristics must be fulfilled by the sample?

There are various techniques of sampling, but they can be broadly grouped into two:

- a** Random or probability sampling.
- b** Non Random or Non Probability sampling.

You will consider only random (probability) sampling.

Random Sampling

In this method, every member of the population has an equal chance of being selected for the sample. Only chance determines which item is to be selected. Three of the most commonly used methods which will be discussed are: **simple random sampling**, **systematic sampling** and **stratified sampling**.

i Simple random sampling (SRS)

Simple random sampling is characterized by random selection of data. To apply this method, you may either use the lottery method or a table of random numbers (attached at the end of the textbook).

The Lottery method

In this method an investigator

- ✓ prepares slips of paper which are identical in size and colour.
- ✓ writes names or code numbers for each member of the population;
- ✓ folds the slips and puts them in a container and mixes them;
- ✓ A blindfold selection is then made until a sample of the required size is obtained.

Example 1 A mathematics teacher in a school wants to determine the average weight of grade 12 students. There are 6 sections of grade 12 in the school. Assuming that there are 45 students in each class and requiring a sample size of 30 (5 from each section), how can she use the lottery method to select her sample?

- Solution**
- a** Prepare 45 cards of same size and colour, with number 0 written on 40 of them and the number 1 written on 5 of them.
 - b** Put the cards on a table with the numbers facing down.
 - c** Invite the students (one at a time) to come and pick a card.
 - d** Those who pick cards with the number one on them will be members of the sample.
 - e** Repeat the same process for each section.

Note:

Maximum care has to be taken at this stage to get accurate data. Inaccurate and inadequate data may lead to wrong conclusions. Thus,

- a** Care should be taken so that each student picks just one card.
- b** The cards should be well shuffled before being placed on the table.
- c** The same set of cards should be used for all the sections.

Using a table of random numbers

For this method, you need to use a table of random numbers, and you need to take the following steps.

- ✓ Each member of the population is given a unique consecutive number.
- ✓ Select arbitrarily one random number from the table of random numbers.
- ✓ Starting with the selected random number, read the consecutive list of random numbers and match these with the members of the population in their consecutive number order.
- ✓ Sort the selected random numbers into either ascending or descending order.
- ✓ If you need a sample of size “ n ”, then select the sample that corresponds with the first “ n ” random numbers.

Example 2 For the problem in Example 1 above, use the random numbers table attached at the end of the textbook to select a sample of 30 students (5 from each section).

Solution

- a** Give each student a role number from 1 to 45 in alphabetical order.
- b** Select arbitrarily one random number from the table of random numbers.
- c** From the selected random number, read 45 consecutive random numbers and attach each to the consecutive numbers given to each member of the population.
- d** Sort the selected random numbers (together with the numbers from 1 – 45) into ascending or descending order.
- e** Take the first 5 random numbers and the corresponding role numbers. The students whose role numbers are selected will be part of the sample.

ii Systematic sampling

Systematic sampling is another random sampling technique used for selecting a sample from a population. In order to apply this method, you take the following steps:

If N = size of the population and n = size of the sample, then we use $k = \frac{N}{n}$ for a sampling interval. After this, you arbitrarily select one number between 1 and k , and then every next sample member is selected by considering the k^{th} member after the selected one.

Example 3 In a class, there are 80 students with class list numbers written from 1-80. You need to select a sample of 10 students. How can you apply the systematic sampling technique?

Solution You apply the systematic sampling technique as follows:

$$N = 80 \quad n = 10 \quad k = \frac{80}{10} = 8$$

First, sort the list in ascending order and choose one number at random from the first 8 numbers. If the selected number is 5, then the sample numbers that you obtain by taking every eighth number until you get the tenth sample number are

$$5, 13, 21, 29, 37, 45, 53, 61, 69, 77$$

What do you think will the sample be, if the first randomly selected number is 3? List them.

Note:

In systematic sampling, you use $S_n = S_1 + (n - 1)k$ where S_1 is the first randomly selected sample, S_n stands for n^{th} member of a sample and k is the sampling interval.

iii Stratified sampling

Stratified sampling is useful whenever the population under consideration has some identifiable stratum or categorical difference where, in each stratum, the data values or items are supposed to be homogeneous. In this method, the population is divided into homogeneous groups or classes called strata and a sample is drawn from each stratum. Once you identify the strata, you select a sample from each stratum either by simple random sampling or systematic sampling.

Consider the following example.

Example 4 If you consider students in a section, you may consider intervals of age as strata. In such a case, you could take the age groups 12 – 14, 15 – 17 and 18 – 20 as stratification of the students.

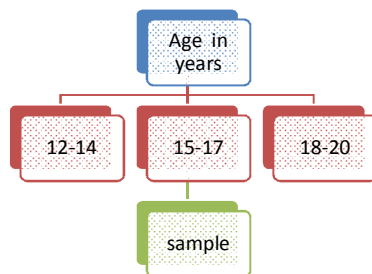

Figure 8.1

Samples are taken from each stratum proportionally. In this case, strata are age groups from 12-14, 15-17 and 18-20.

So far, the three different sampling techniques are discussed. However, no one technique is better than the others. Each has its own advantages and limitations. Some advantages and limitations of random sampling are mentioned below.

Advantages of random sampling

- ✓ It is free from any personal bias of the investigator.
- ✓ The sample is a better representative.

Limitations of random sampling

- ✓ It needs skill and experience.
- ✓ It requires time to plan and carry out.

Exercise 8.1

- 1 Define the term statistics.
- 2 Describe the difference between the statistical terms *population* and *sample*.
- 3 Explain and describe three sampling techniques.
- 4 By using further reading, explain other sampling techniques (probability and non-probability sampling).
- 5 From a population of size 100 listed 1-100, if you need to select a sample of size 20 and the first randomly selected number is 4, determine:
 - a the sampling interval;
 - b all members of the sample.
- 6 Discuss the advantages and limitations of the three sampling techniques.

8.2

REPRESENTATION OF DATA

ACTIVITY 8.3

The following data of students' weights (in kg) is collected

65	48	52	55	62	58	47	53	65	71	54
50	62	51	49	54	60	68	53	57	62	59



Prepare a grouped frequency table for the data using a class width of 5.

As you well know, raw data which has been collected and edited, will not immediately give required information. It usually needs to be put into a form that makes it easier to understand and interpret, such as tables, graphs or diagrams. You studied how to represent data in tables and charts in Grade 9. Here, you will consider some practical data representations discussing their importance, with their strengths and weaknesses in:

- a computational analysis and decision making,
- b providing information for public awareness and other purposes.

Tabular methods of data presentation

One of the common ways of representing data is the use of tables. Often, you use frequency distribution tables. A frequency distribution table is a table which shows the list of all data values obtained, with their respective frequencies.

Example 1 The following represents the ages of 20 women taken at the time when they gave birth to their first child.

24, 25, 27, 26, 22, 28, 24, 25, 23, 24, 27, 26, 25, 24, 25, 25, 24, 25, 24, 26

Represent the data using a discrete frequency distribution table.

Solution You can represent the above data using a discrete frequency distribution as follows:

Age (in years) (x)	Tally marks	Number of women (f)
22		1
23		1
24	HHH	6
25	HHH	6
26		3
27		2
28		1

From this frequency distribution table, you can draw some conclusions about the women. You can identify that the majority of the women first gave birth at the ages of 24 and 25. The above data can be further summarized using a grouped frequency distribution as follows:

Age (in years)	Tally	Number of women
22 – 24	HHH	8
25 – 27	HHH HHH	11
28 – 30		1

This provides more concise information. From this, you can, for example, say that the majority of the women first gave birth before the age of 28.

Graphical methods of data presentation

The other way in which you represent data is to use graphs. Graphical representations that you are going to discuss in the following section include Bar charts, Pie charts and frequency graphs.

Example 2 The following bar chart represents students' enrolments in the preparatory programs in Ethiopia from 1996 E.C to 2000 E.C. Can you use the Bar chart to answer the following?

- Is the enrolment increasing or decreasing in successive years?
- Between which two years does female enrolment increase significantly?

**ENROLLMENT IN PREPARATORY PROGRAM (11-12)
BY GENDER**

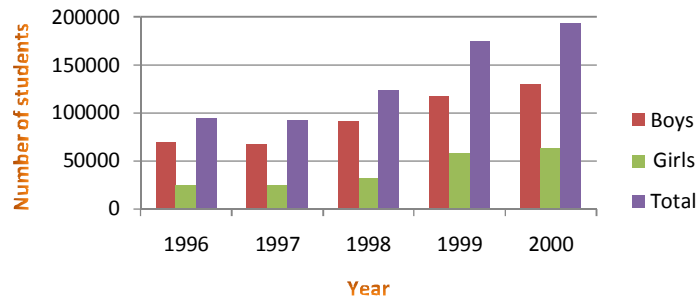

Figure 8.2

Solution

- a** The enrolment is increasing starting from 1998.
- b** There seems to be no change in the number of enrolments in the first two years. But from 1999 onwards, there is a considerable increase in enrolment of girls.

From the above examples, you see that data representation can be a useful way to present information, from which conclusion could be drawn.

Example 3 The following bar chart represents percentages of women who oppose female genital mutilation, by educational level.

- a** Determine the four countries that have a larger difference in prevalence between older women (ages 35 to 39) and younger women (ages 15 to 19).
- b** What significance does this have for policy makers who are working to stop female genital mutilation?

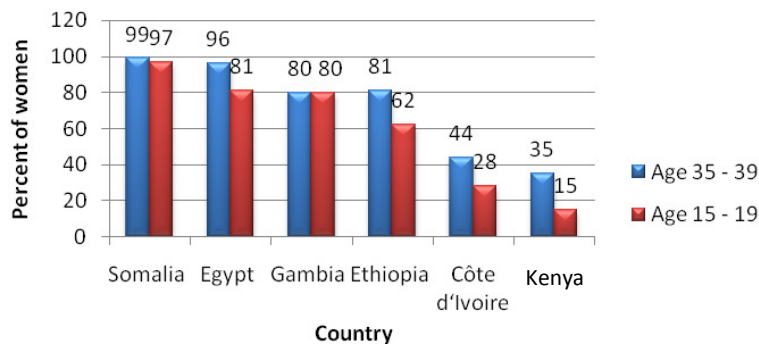

Figure 8.3: Source: Population Reference Bureau, Female Genital Mutilation/Cutting: Data and Trends update 2010

Solution

- a** The four countries in the survey that have larger difference in prevalence between older women (ages 35 to 39) and younger women (ages 15 to 19) are Kenya, Ethiopia, Côte d'Ivoire, and Egypt.

- b** For policy makers, it might suggest that the countries with larger difference in prevalence between older women (ages 35 to 39) and younger women (ages 15 to 19) are doing better. This may be a sign that the practice is being abandoned.

Example 4 An agricultural firm, which plants coffee, tea, and other herbs, has conducted a survey on the use of coffee, tea and other herbal drinks by a community, in order to assess the market potential for its products. How can the chart below help it in making decisions?

Solution Coffee seems to have more of a market than the other products. The firm might need to launch an awareness raising program about the health benefits of drinking herbal drinks.

Drinking habits of a community

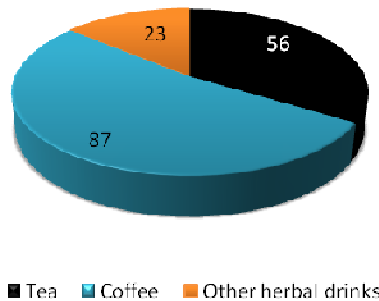

Figure 8.4

Advantages of Graphical Presentation of Data

- 1 They are attractive to the eye. Since graphs have eye catching power, they can convey messages easily.
e.g. While reading books or newspapers, you first go to the pictures.
- 2 They are helpful for memorizing facts, because the impressions created by diagrams and graphs can be retained in your mind for a long period of time.
- 3 They facilitate comparison. They help one in making quick and accurate comparisons of data. They bring out hidden facts and relationships. The information presented can be easily understood at a glance.

In the following sub-unit, you will look at the construction and interpretation of graphs.

Exercise 8.2

The following is the weight in kilograms of 30 students in a class.

52, 48, 55, 56, 57, 59, 60, 60, 52, 58, 55, 49, 50, 51, 52, 51, 57, 51, 54, 53, 55, 51, 53, 50, 60, 54, 50, 52, 48, 57

- 1 Construct both discrete and continuous frequency distributions for the above data.
- 2 Answer the following questions:
 - i What is the number of students whose weight is

a between 50 and 55 kg	b less than 53 kg
c more than 54 kg	d between 55 and 60 kg
 - ii In which weight group do the weights of the majority of the students lie?

8.3 CONSTRUCTION AND INTERPRETATION OF GRAPHS

In the above sub unit, you discussed the advantages of representing data using different forms such as tables, graphs or diagrams. Here, you will see ways to organize and present data such as histograms, frequency polygons and frequency curves, bar charts, line graphs and pie charts of frequency distributions.

ACTIVITY 8.4



The following is ungrouped data of the weight of 30 students in a class (in kilograms)

52, 48, 55, 56, 57, 59, 60, 60, 52, 58, 55, 49, 50, 51, 51
 52, 57, 51, 54, 53, 55, 51, 53, 50, 60, 54, 50, 52, 48, 57

Draw a histogram.

8.3.1 Graphical Representation of Grouped Data

A frequency distribution can be graphically presented in any one of the following ways:

- i **Histograms**
- ii **Frequency polygons**
- iii **Frequency curves**

ACTIVITY 8.5



Consider the following grouped frequency distribution that represents the weekly wages of 100 workers.

Weekly wages in Birr (class limits)	Class boundaries	Class mid point	Number of workers
140 - 159	139.50 - 159.50	149.50	7
160 - 179	159.50 - 179.50	169.50	20
180 - 199	179.50 - 199.50	189.50	33
200 - 219	199.50 - 219.50	209.50	25
220 - 239	219.50 - 239.50	229.50	11
240 - 259	239.50 - 259.50	249.50	4
Total			100

- 1 Locate the class boundaries along the x -axis (horizontal axis).
- 2 Assign a rectangular bar for each class between its lower class boundary and upper class boundary.
- 3 Fix the height of each bar as the frequency of its class.

i Histograms

Histograms are used to illustrate grouped or continuous data. As you may recall, there is an important difference between a bar chart and a histogram. A bar chart shows qualitative or discrete data and hence the variable axis is just divided into spaces. On the other hand, a histogram illustrates grouped or continuous data and therefore the variable axis is a continuous number line. To draw a histogram, you need to take note of the following.

Note:

- i Construct a grouped frequency distribution.
- ii Locate class boundaries along the x -axis (horizontal axis).
- iii The width of the bar indicates the class interval.
- iv The height of the bars indicate the frequency of each class.

Example 1 The histogram of the data given in **Activity 8.5** above will look like the following:

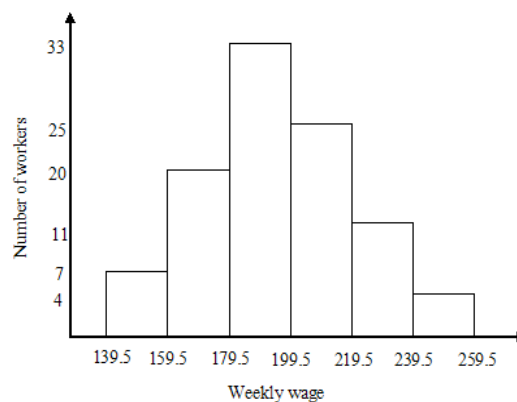

Figure 8.5

Example 2 The Soil Laboratory section of an agricultural institute has collected the following data about the length of a kind of earthworm, which plagues the surrounding farms.

Length (cm)	0.5-1.5	1.5-2.5	2.5-3.5	3.5-4.5	4.5-5.5	5.5-6.5	6.5-7.5	7.5-8.5	8.5-9.5
Frequency	4	7	14	20	19	17	10	7	2

Solution The histogram is given below. You use a histogram because the data is continuous.

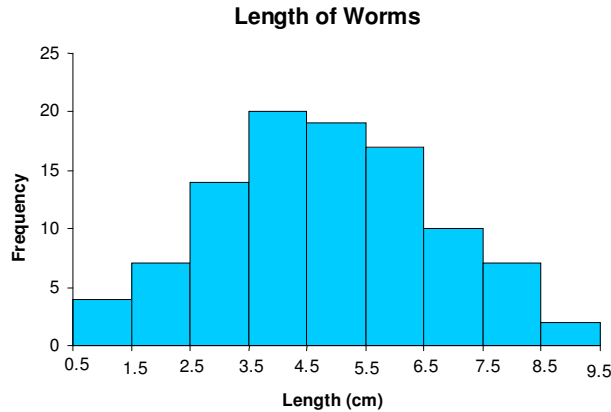

Figure 8.6

ii Frequency polygons

This is another type of graph used to represent grouped data. In drawing a frequency polygon, you plot the mid points (class-marks) of the class intervals on the horizontal axis and the corresponding frequencies on the vertical axis. After plotting the points, you join them by consecutive line segments. The resulting graph is a frequency polygon.

Example 3 The following table represents marks of students in Mathematics. Construct a frequency polygon.

Marks	Mid point	Number of students
15 - 20	17.5	3
20 - 25	22.5	17
25 - 30	27.5	10
30 - 35	32.5	5

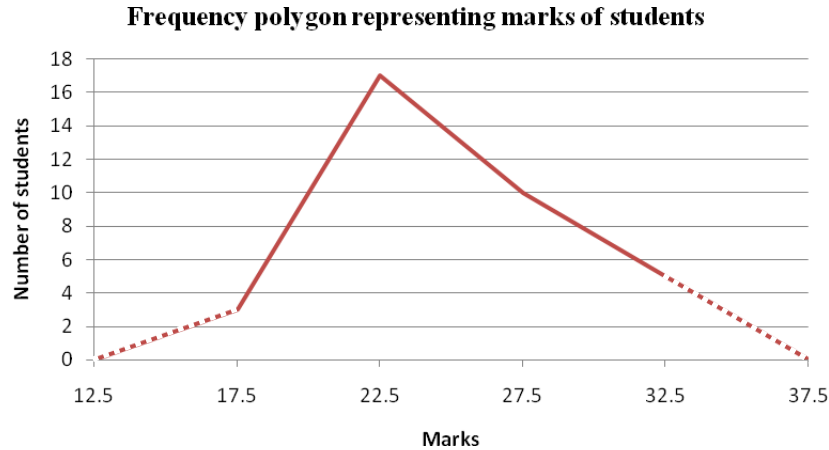

Figure 8.7

Note:

- 1** The dotted lines at both ends show that they are not part of the data. They are needed in order for the polygon to be closed.
- 2** A frequency polygon will be more meaningful if other similar data is superimposed on the same graph. That is, if the above marks are of section A students, we can plot the marks of section B students and hence compare their performance.
- 3** It is possible to draw a frequency polygon from a histogram simply by joining the mid points of each bar. For example, the frequency polygon of the grouped data of wages of workers is shown below.

Example 4 In the figure below, the frequency polygon in red is drawn from the histogram in **Example 1** above.

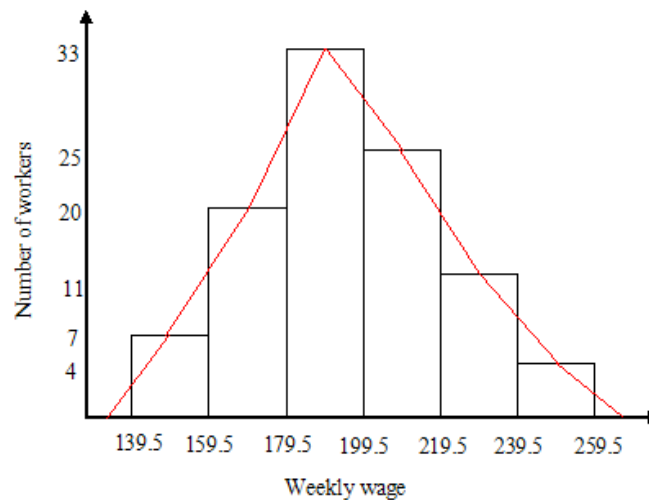

Figure 8.8

iii Cumulative frequency curve (Ogive)

To draw a cumulative frequency curve (Ogive), you have to use a cumulative frequency table. An example is given below:

Example 5 Draw a cumulative frequency curve (Ogive) for the data in **Example 3** above.

Solution

Marks	Mid point	Number of students (f)	Cumulative Frequency
15 - 20	17.5	3	3
20 - 25	22.5	17	20
25 - 30	27.5	10	30
30 - 35	32.5	5	35

The cumulative frequency above shows the number of students who scored less than or equal to the upper class boundary of the corresponding class. For instance, 20 represents the number of students whose score is less than or equal to 25.

To draw the Ogive, you plot each cumulative frequency against its upper class boundary.

OGIVE CURVE

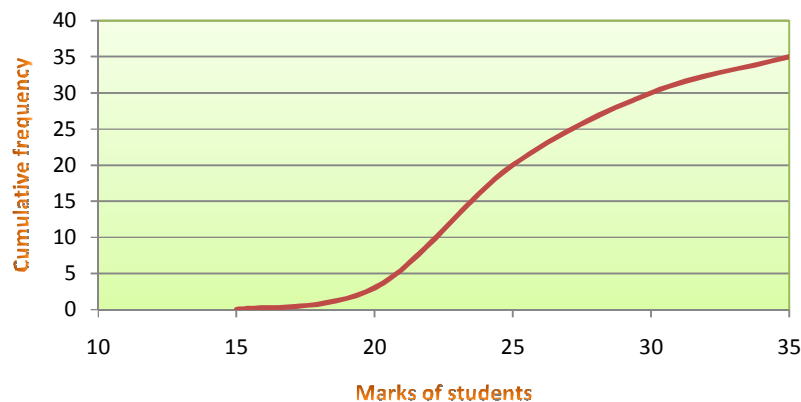

Figure 8.9

Histograms of grouped frequency distributions often display a low frequency on the left, rise steadily up to a peak and then drop down to a low frequency again on the right. If the peak is in the centre and the slopes on either side are virtually equal to each other, then the distribution is said to be **symmetrical**; otherwise, the distribution is **skewed**. Skewness is lack of symmetry in the data.

For a skewed distribution, if the peak lies to the left of the centre, then the distribution is **positively - skewed**, and if the peak of the distribution is to the right of the centre, the distribution is said to be **negatively - skewed**.

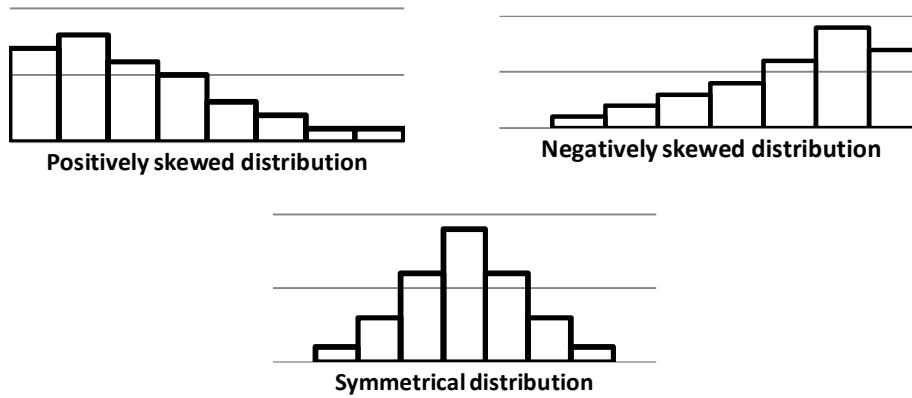

Figure 8.10

iv Frequency curves

Frequency curves are simply smoothed curves of frequency polygons.

Example 6 Construct a frequency curve for the frequency distribution of the wages of workers given in **Activity 8.5**.

Solution

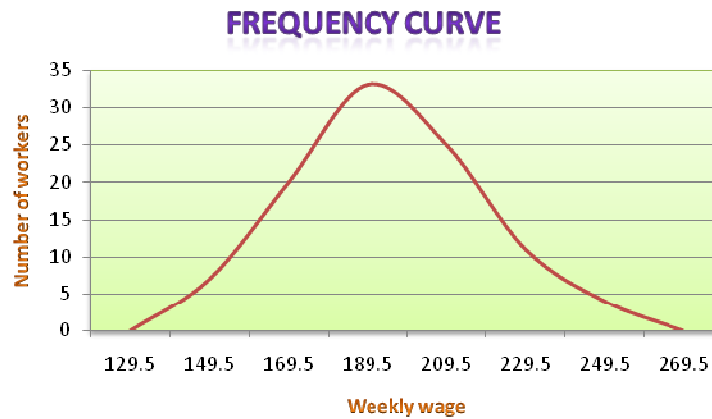

Figure 8.11

Frequency curves can also be used to show skewness. For the grouped frequency distributions in **Figure 8.10**, the corresponding frequency curves are given below.

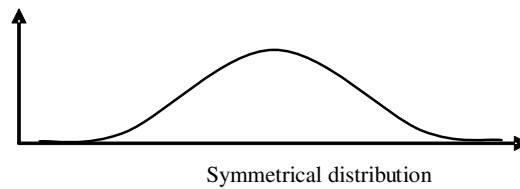

Figure 8.12

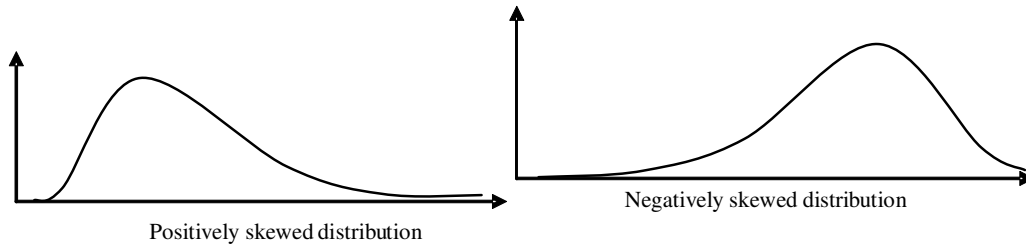

Figure 8.13

Example 7 Draw the frequency curve for the data in Example 2 above.

Solution The frequency curve is given below:

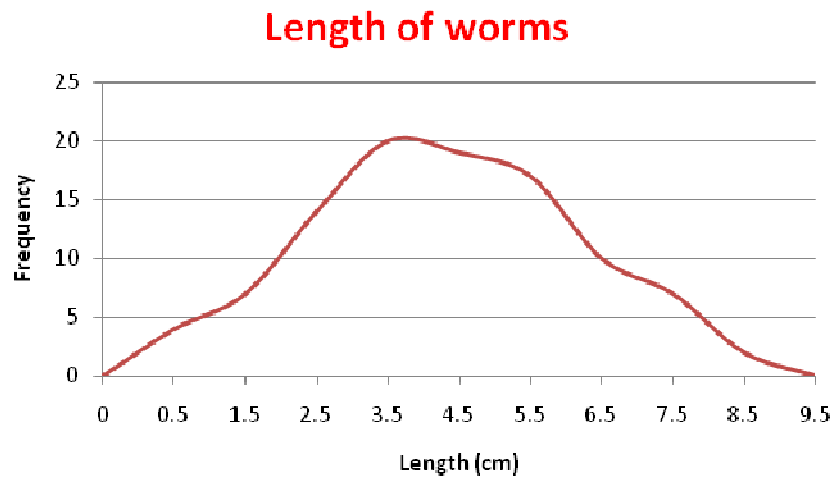

Figure 8.14

Representation of data using diagrams (Charts)

So far, we discussed representation of data using histograms, frequency polygons and frequency curves. There are also other forms of data representation. Here, we will see representation of data using Bar charts, line graphs and pie charts. First of all, do the following **Activity**.

v Bar charts

ACTIVITY 8.6



- 1 What is Bar chart?
- 2 Considering the following chart, explain the similarity and difference between this chart and the histogram in **Activity 8.5**.

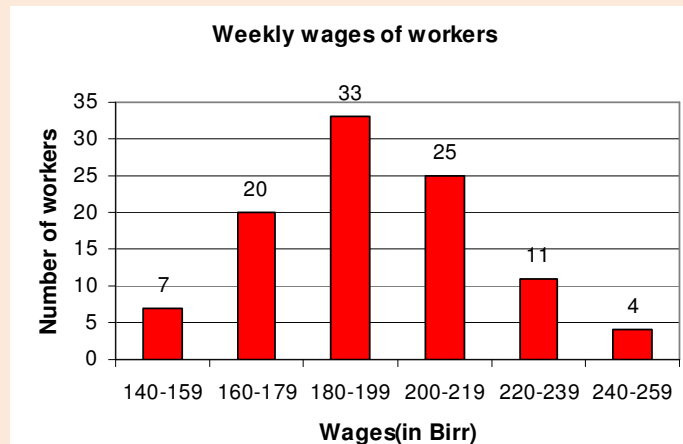

Figure 8.15

Bar charts are like histograms in that frequencies are represented with rectangular bars but, with a space between each bar. Bar charts are one of the most commonly used data representations found in newspapers, magazines and report papers.

There are different types of bar charts

- ✓ simple bar charts
- ✓ component (subdivided) bar charts
- ✓ grouped (multiple) bar charts
- a Simple bar charts

A simple bar chart is a type of bar chart that simply represents the frequencies of single items without considering the component items.

Example 8 The following table depicts types and amount of pairs of shoes produced by a certain factory for four consecutive years (in thousands)

Year	Boots	Normal	Total
1990	3	7	10
1991	5	10	15
1992	4	6	10
1993	10	15	25

If you consider the total number of pairs of shoes produced, its simple bar chart will look like the following, which relates only year and total pairs of shoes produced in that year. Notice that you are considering a single item without considering the components.

Simple Bar chart showing number of pairs of shoes produced in a factory each year

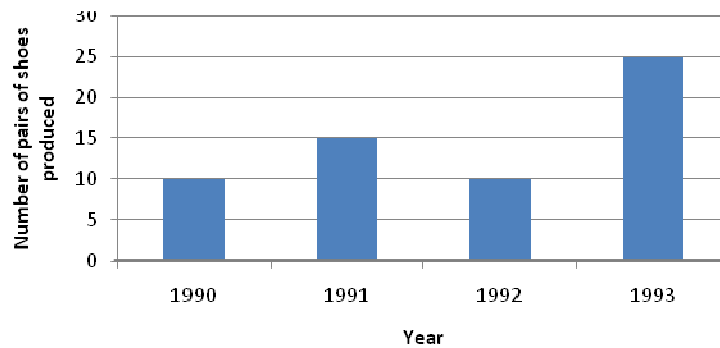

Figure 8.16

In order to draw a bar chart, take the following steps.

- 1** Set horizontal and vertical axes.
- 2** Locate data values/ categories on the horizontal axis and frequency on the vertical axis.
- 3** Draw rectangular bars.
- 4** Notice that the space between each bar must be the same.

You can also use Microsoft Excel or any other statistical software to draw such charts.

b Component bar charts

In addition to the features of a simple bar chart, a component bar chart takes into account the relative contribution of each part or component to the total.

See the component bar chart for the data given in the previous example.

Component Bar chart showing number of pairs of shoes produced in a factory each year

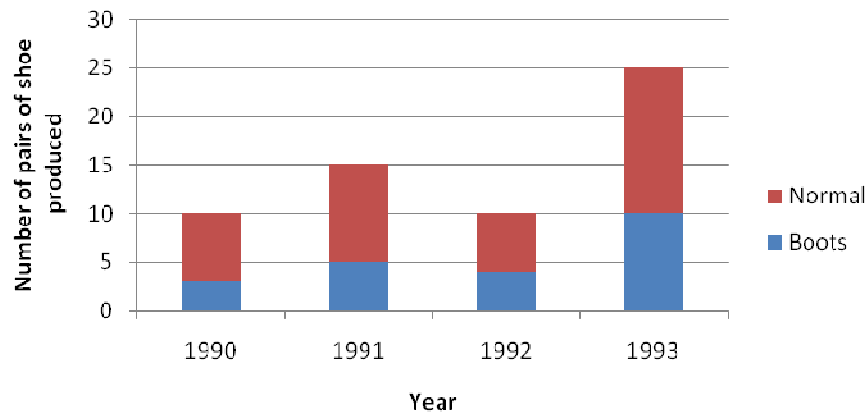

Figure 8.17

Note:

✓ This component bar chart describes not only the total production of pairs of shoes but also the types of shoes produced, one on top of the other so that each bar sums up the total.

c Multiple bar charts

These are bar charts that show the various components of an item side by side. They help to facilitate comparison. The multiple bar chart for the above data is given below.

Multiple Bar chart showing pairs of shoes produced in a factory each year

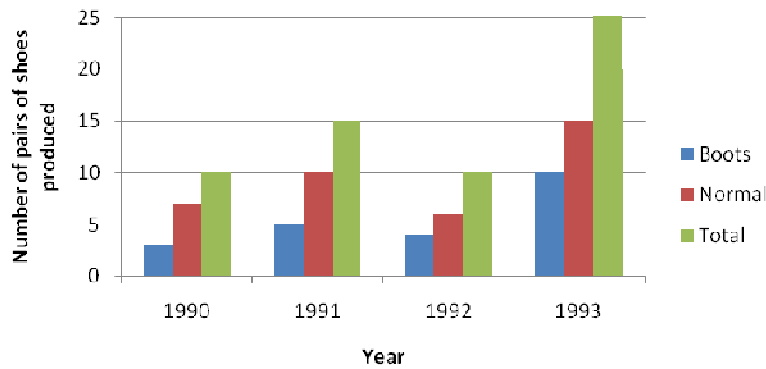

Figure 8.18

vi Line graphs

A line graph is another useful way to represent data, especially when the categories represent time. Such graphs portray changes in amount with respect to time by a series of line segments. These graphs are useful for comparing series of data.

Example 9 The following data represents daily sales of a certain shop for six days.

Days	M	T	W	Th	F	Sa
Sales in hundreds of Birr	4	3	6	8	2	5

Sales in hundreds of Birr

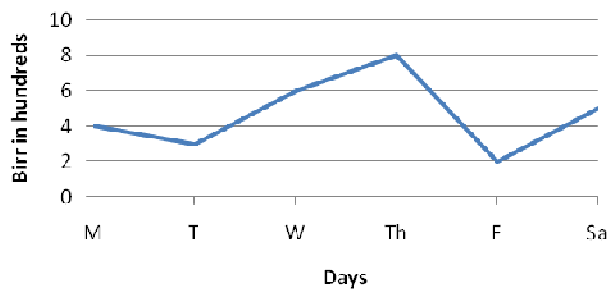

Figure 8.19

In order to draw a line graph, first plot each quantity and then connect each plot with a line segment.

vii Pie charts

A pie chart is a pictorial representation of data with several subdivisions in a circular region. The various components are converted into degrees by taking proportions of 360° .

In order to draw pie chart

- i Draw a circle with convenient radius.
- ii Find the relative frequency of each item.
- iii Convert each relative frequency into an angle.
- iv Divide the circle according to these angles.
- v Different components appear as adjacent sectors of the circle.

Example 10 The following data depicts preferred means of transport for 100 people.

Type of transport	Taxi	Bus	Private
People who used	35	50	15

To draw a pie chart that represents the given data, first you need to determine the relative frequency (from 360°) of the users of each type of transport to calculate the angles:

Type of transport	No of people	Relative frequency	Angle
Taxi	35	$\frac{35}{100} \times 360^\circ =$	126°
Bus	50	$\frac{50}{100} \times 360^\circ =$	180°
Private car	15	$\frac{15}{100} \times 360^\circ =$	54°

Transport Preference

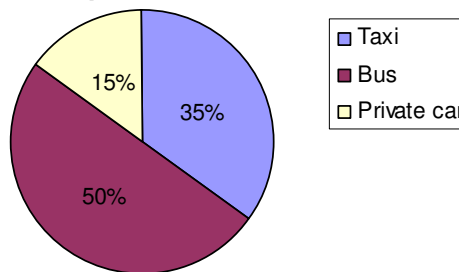

Figure 8.20

Note:

- 1 In the Pie chart, notice that the area of the sector is proportional to the relative frequency.
- 2 Components representing equal percentages will have equal areas in the circle.
- 3 Pie charts may not be effective if there are too many categories.

Exercise 8.3

- 1 The following table depicts ages of a sample of people living in a certain city. Construct a histogram.

Age (in years)	10 – 15	15 - 20	20 - 25	25 - 30	30 - 35
Number of people	17	23	15	14	12

- 2 Draw a frequency polygon and frequency curve for the following data.

Age (in years)	20 - 26	26 - 32	32 - 38	38 - 44	44 - 50
Number of people	8	3	11	7	12

- 3 The following table represents the costs in thousands of Birr of building a house in three months.

Month	Items			Total
	Cement	Steel	Labour	
Meskerem	70	90	50	210
Tikimt	80	100	70	250
Hidar	50	45	45	155

Represent the above data using the three types of bar charts.

- 4 Represent the following using any of the three types of bar charts.

Year	Production in tonnes			Total
	Teff	Wheat	Maize	
1996	80	60	70	210
1997	100	150	180	430
1998	150	200	250	600

- 5 The age distribution of people in a village is given as follows. Fill in the “Degree” column and construct a pie chart.

Age	Number of people	Degree
Under 20	15	
20 – 40	60	
40 – 60	20	
Over 60	5	

6 Draw a pie chart for each of the following sets of data.

a

Crop	Production in tonnes
Teff	500
Wheat	700
Maize	800
Barley	500

b

Expenditure	Amount (in birr)
Rent	500
Transport	200
Electricity	1500
Education	100

8.4 MEASURES OF CENTRAL TENDENCY AND MEASURES OF VARIABILITY

8.4.1 Measures of Central Tendency

In previous grades, you studied the different measures of central tendency (mean, mode and median) for ungrouped and grouped data and measures of variation that included range, variance and standard deviation. In this sub-unit, you will briefly revise these concepts with the help of examples and proceed to see other measures of variation such as inter-quartile range and mean deviation.

ACTIVITY 8.7

Considering the following ungrouped data: 50, 70, 45, 48, 60, 68, 57, 63, 62, 75, 54, 50, 55, 49, 53 of the weights in kg of 15 sample students, find:

- a** the mean
- b** the median
- c** the range
- d** the first and third quartiles
- e** the mode and
- f** the standard deviation.



From this **Activity**, it is hoped that you have revised the measures of central tendency and measures of dispersion for ungrouped data. The same approach holds true for grouped data as well. Some examples are given below.

Example 1 Considering the following grouped frequency distribution of weight of students:

Weight (in k.g) x	Class mid point (m)	Number of students (f)
48 - 49	48.5	5
50 - 51	50.5	23
52 - 53	52.5	15
54 - 55	54.5	25
56 - 57	56.5	8
58 - 59	58.5	7
		$\sum f = 83$

Calculate **a** the mean **b** the median
c the range **d** the standard deviation

Solution a The mean is $\bar{x} = \frac{\sum fm}{\sum f} = \frac{4415.5}{83} = 53.20 \text{ kg}$

b The median is

$$m_d = L + \left(\frac{\left(\frac{n}{2} - cf_b \right)}{f_c} \right) w$$

$$\begin{aligned} \text{so median} &= 51.5 + \left(\frac{\left(\frac{83}{2} - 28 \right)}{15} \right) \times 2 = 51.5 + \frac{(41.5 - 28)}{15} \times 2 = 51.5 + \frac{(13.5)}{15} \times 2 \\ &= 51.5 + 1.8 = 53.3 \text{ kg} \end{aligned}$$

c The range is the difference between upper class boundary of the highest class B_u (H) and the lower class boundary of the lowest class B_L (L). Thus, the range is $R = 59.5 - 47.5 = 12$

d The standard deviation:

Weight (in k.g) x	Class mid point (m)	Number of students (f)	$x_i - 53.20$	$(x_i - 53.69)^2$	$f_i(x_i - 53.69)^2$
48 - 49	48.5	5	-4.70	22.09	110.45
50 - 51	50.5	23	-2.70	7.29	167.67
52 - 53	52.5	15	-0.70	0.49	7.35
54 - 55	54.5	25	1.30	1.69	42.25
56 - 57	56.5	8	3.30	10.89	87.12
58 - 59	58.5	7	5.30	28.09	196.63
$\sum f = 83$			$\sum_{i=1}^n f_i (x_i - \bar{x})^2 = 611.47$		

$$\text{Thus, } s = \sqrt{\frac{\sum_{i=1}^n f_i (x_i - \bar{x})^2}{\sum_{i=1}^n f_i}} = \sqrt{\frac{611.47}{83}} = \sqrt{7.37} = 2.71 \text{ kg}$$

Example 2 Calculate Q_1 , Q_2 and Q_3 of the following data.

x	f	cf
10 - 19	3	3
20 - 29	5	8
30 - 39	14	22
40 - 49	7	29

Solution

i Q_1 is the $\left(\frac{29}{4}\right)^{\text{th}}$ item = $(7.25)^{\text{th}}$ item, in the 2nd class

$$Q_1 = 19.5 + \left(\frac{7.25 - 3}{5}\right)10 = 19.5 + 8.5 = 28$$

ii Q_2 is the $\left(\frac{2 \times 29}{4}\right)^{\text{th}}$ item = $(14.5)^{\text{th}}$ item, in the 3rd class

$$Q_2 = 29.5 + \left(\frac{14.5 - 8}{14}\right)10 = 29.5 + 4.64 = 34.14$$

iii Q_3 is the $\left(\frac{3 \times 29}{4}\right)^{\text{th}}$ item = $(21.75)^{\text{th}}$ item, in the 3rd class

$$Q_3 = 29.5 + \left(\frac{21.75 - 8}{14}\right)10 = 29.5 + 9.82 = 39.32$$

Example 3 The following is the age distribution of a sample of students. Estimate the modal age.

age	Number of students
10 - 14	2
15 - 19	7
20 - 24	9
25 - 29	4
30 - 34	3

Solution The modal class is the 3rd class because its frequency is the highest. The lower class boundary of this class is 19.5

$$\therefore L = 19.5$$

$$w = 24.5 - 19.5 = 5, \Delta_1 = 9 - 7 = 2, \Delta_2 = 9 - 4 = 5$$

$$\text{mode} = L + \left(\frac{\Delta_1}{\Delta_1 + \Delta_2}\right)w = 19.5 + \left(\frac{2}{2+5}\right)5 = 19.5 + \frac{10}{7} = 19.5 + 1.43 = 20.93$$

Exercise 8.4

- 1** Calculate the arithmetic mean of each of the following data sets:
- a** 76, 78, 69, 75, 84, 92, 11, 81, 10, 95 **b** 22, 22, 22, 22, 22, 22, 22
- 2** If the mean of 4, 7, 8, 6, 5 is 6, then, find the mean of $4 + 8$, $7 + 8$, $8 + 8$, $6 + 8$, $5 + 8$.
- 3** If the mean of 5, 6, 10, 15, 19 is 11 then, find the mean of 2×5 , 2×6 , 2×10 , 2×15 , 2×19 .
- 4** If the mean of a , b , c , d is 5 then, find the mean of $3a + 3$, $3b + 3$, $3c + 3$, $3d + 3$.
- 5** Find the mean of each of the following data.

a

x	7	10	11	15	19
f	3	2	4	8	6

b

Marks	20	30	40	50	60	70
Number of students	8	12	20	10	6	4

c

Marks	0 - 9	10 - 19	20 - 29	30 - 39	40 - 49
f	5	10	8	13	4

- 6** Find the median and mode of each of the following data sets.

a 2, 7, 6, 8, 10, 1**b**

x	10	12	15	16
f	4	6	8	3

c

Age	1 - 3	4 - 6	7 - 9	10 - 12	13 - 15
f	2	1	8	17	11

- 7** Find Q_1 , Q_2 and Q_3 of each of the following.

a 18, 11, 26, 20, 16, 8, 22, 23, 8, 12, 15, 13**b**

x	5 - 9	10 - 14	15 - 19	20 - 24	25 - 29
f	3	4	6	7	3

8.4.2 Further on Measures of Variation

In previous grades, you studied the definition of variation and measures of variation such as range, variance and standard deviation. In this sub unit, you are going to discuss additional measures of variation, namely, mean deviation and some relative measures of variation such as the coefficient of variation.

Recall that a measure of variation can be defined in either of the following ways:

- a** The degree to which numerical data tends to spread about an average;
- b** The scatter or variation of variables about a central value.

Variation can be measured either absolutely or relatively.

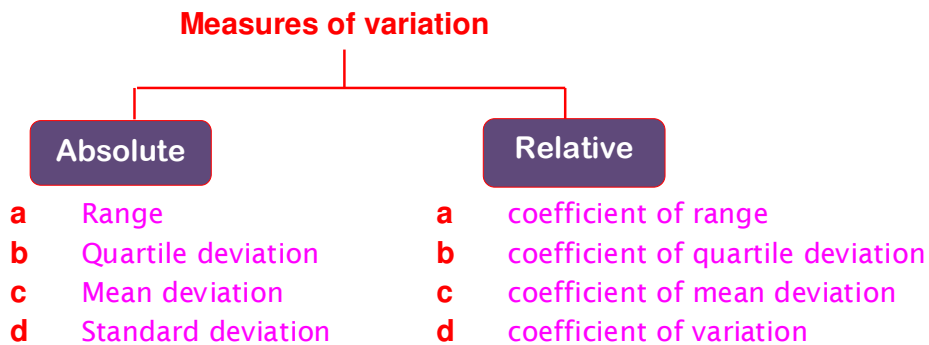

Note:

- ✓ Absolute measures are expressed in concrete units, i.e. the units in which the data value is expressed, e.g. Birr, kg, m, etc.
- ✓ A relative measure of variation is the ratio of measure of the absolute variation to its corresponding average. It is a pure number that is independent of the unit of measurement.

Mean deviation (MD)

When we calculated standard deviation, you may have noticed that it is the square root of the sum of the squares of the deviations of each observation from the mean, divided by $n-1$, where n stands for sample size. Another measure of deviation that also considers all members of a data set is the mean deviation, which you are going to see now.

ACTIVITY 8.8



The following data represents mathematics examination scores out of 10 of ten students.

2, 6, 4, 9, 5, 7, 3, 6, 8, 6

- 1** Find the mean of the data.
- 2** Find the deviation of each value from the mean.

- 3 Determine the mean of these deviations.
- 4 Observe that this mean is 0. What will the mean of the deviation be if you consider the absolute values of each deviation?

Definition 8.1

Mean deviation is the sum of deviations (in absolute value) of each item from the average divided by the number of items. It can be considered as the mean of the deviations of each value from a central value.

Note:

A deviation may be taken from the mean, median or mode.

You will now see how to calculate mean deviation about the mean, the median and the mode for ungrouped data, for discrete frequency distributions and for grouped data.

1 Mean deviation for ungrouped data

i Mean deviation from the mean $MD(\bar{x})$

To calculate the mean deviation from the mean, take the following steps.

- Step 1:** Find the mean of the data set.
- Step 2:** Find the deviation of each item from the mean regardless of sign (since mean deviation assumes absolute value).
- Step 3:** Find the sum of the deviations.
- Step 4:** Divide the sum by the total number of items in the data set.

$$MD(\bar{x}) = \frac{|x_1 - \bar{x}| + |x_2 - \bar{x}| + |x_3 - \bar{x}| + \dots + |x_n - \bar{x}|}{n} = \frac{\sum_{i=1}^n |x_i - \bar{x}|}{n}$$

ii Mean deviation about the median $MD(m_d)$

To calculate the mean deviation from the median, simply use the median in place of the mean and proceed in the same way, as follows.

- Step 1:** Find the median of the data set.
- Step 2:** Find the absolute deviation of each item from the median.
- Step 3:** Find the sum of the deviations.
- Step 4:** Divide the sum by the total number of items in the data set.

$$MD(m_d) = \frac{|x_1 - m_d| + |x_2 - m_d| + |x_3 - m_d| + \dots + |x_n - m_d|}{n} = \frac{\sum_{i=1}^n |x_i - m_d|}{n}$$

iii Mean deviation about the mode MD(m_0)

Again proceed in a similar way:

- Step 1:** Find the mode of the data set.
- Step 2:** Find the absolute deviation of each item from the mode.
- Step 3:** Find the sum of the deviations.
- Step 4:** Divide the sum by the total number of items in the data set.

$$MD(m_0) = \frac{|x_1 - m_0| + |x_2 - m_0| + |x_3 - m_0| + \dots + |x_n - m_0|}{n} = \frac{\sum_{i=1}^n |x_i - m_0|}{n}$$

Example 4 Find the mean deviation about the mean, median and mode of the following data.

5, 8, 8, 11, 11, 11, 14, 16

a Mean deviation about the mean, $MD(\bar{x})$:

Step 1: Calculate the mean of the data set.

$$\bar{x} = \frac{5 + 8 + 8 + 11 + 11 + 11 + 14 + 16}{8} = \frac{84}{8} = 10.5$$

Step 2: Find the absolute deviation of each data item from the mean

x	$ x - \bar{x} $
5	5.5
8	2.5
8	2.5
11	0.5
11	0.5
11	0.5
14	3.5
16	5.5
$\sum x - \bar{x} = 21$	

Step 3: Find the sum of the deviations, which is 21.

Step 4: Divide the sum by the total number of items in the data set.

$$MD(\bar{x}) = \frac{\sum |x - \bar{x}|}{n} = \frac{21}{8} = 2.625$$

b Mean deviation about the median, MD(md)

Step 1: Calculate the median of the data set.

$$M_d = \frac{\left(\frac{8}{2}\right)^{\text{th}} \text{ item} + \left(\frac{8}{2} + 1\right)^{\text{th}} \text{ item}}{2} = \frac{4^{\text{th}} \text{ item} + 5^{\text{th}} \text{ item}}{2} = \frac{11 + 11}{2} = 11$$

Step 2: Find the absolute deviation of each data item from the median.

x	$ x - m_d $
5	6
8	3
8	3
11	0
11	0
11	0
14	3
16	5
	$\sum x - m_d = 20$

Step 3: Find the sum of the deviations, which is 20.

Step 4: Divide the sum by the total number of items in the data set.

$$MD(m_d) = \frac{\sum |x - m_d|}{n} = \frac{20}{8} = 2.5$$

c Mean deviation about mode, MD(m₀)

Step 1: Calculate (identify) the mode of the data set mode = 11

Step 2: Find the absolute deviation of each data item from the mode.

x	$ x - m_0 $
5	6
8	3
8	3
11	0
11	0
11	0
14	3
16	5
	$\sum x - m_0 = 20$

Step 3: Find the sum of the deviations, which is 20.

Step 4: Divide the sum by the total number of items in the data set

$$MD(m_0) = \frac{\sum |x - m_0|}{n} = \frac{20}{8} = 2.5$$

2 Mean deviation for discrete frequency distributions

To calculate the mean deviation for a discrete frequency distribution about the mean, the median and the mode you take similar steps as in the process for discrete data.

If $x_1, x_2, x_3, \dots, x_n$ are values with corresponding frequencies f_1, f_2, \dots, f_n , then the mean deviation is given as follows.

i Mean deviation about the mean $MD(\bar{x})$

Step 1: Find the mean of the data set.

Step 2: Find the absolute deviation of each item from the mean.

Step 3: Multiply each deviation by its corresponding frequency.

Step 4: Find the sum of these deviations multiplied by their frequencies.

Step 5: Divide the sum by the sum of the frequencies in the data set.

Following the steps outlined above, you will get the mean deviation about the mean to be as follows.

$$MD(\bar{x}) = \frac{f_1|x_1 - \bar{x}| + f_2|x_2 - \bar{x}| + f_3|x_3 - \bar{x}| + \dots + f_n|x_n - \bar{x}|}{f_1 + f_2 + f_3 + \dots + f_n} = \frac{\sum_{i=1}^n f_i |x_i - \bar{x}|}{\sum_{i=1}^n f_i}$$

ii Mean deviation about the median $MD(m_d)$

Here, we simply need to replace the role of the mean by the median and follow each step as above. This will give us the mean deviation about the median to be:

$$MD(m_d) = \frac{f_1|x_1 - m_d| + f_2|x_2 - m_d| + f_3|x_3 - m_d| + \dots + f_n|x_n - m_d|}{f_1 + f_2 + f_3 + \dots + f_n} = \frac{\sum_{i=1}^n f_i |x_i - m_d|}{\sum_{i=1}^n f_i}$$

iii Mean deviation about the mode $MD(m_o)$

The steps that we need to follow here are also the same, but we shall use the mode instead of the mean or the median. Following the steps, we will get the mean deviation about the mode to be:

$$MD(m_o) = \frac{f_1|x_1 - m_o| + f_2|x_2 - m_o| + f_3|x_3 - m_o| + \dots + f_n|x_n - m_o|}{f_1 + f_2 + f_3 + \dots + f_n} = \frac{\sum_{i=1}^n f_i |x_i - m_o|}{\sum_{i=1}^n f_i}$$

Example 5 Find the MD of the following data about the mean, the median and the mode.

x	f	cf
9	3	3
15	5	8
21	10	18
27	12	30
33	7	37
39	3	40

1 Calculating the mean, the median and the mode first, we get

a The mean $= \bar{x} = \frac{3 \times 9 + 5 \times 15 + 10 \times 21 + 12 \times 27 + 7 \times 33 + 3 \times 39}{3 + 5 + 10 + 12 + 7 + 3} = \frac{984}{40} = 24.6$

b The median $= m_d = \frac{\left(\frac{40}{2}\right)^{th} + \left(\left(\frac{40}{2}\right) + 1\right)^{th}}{2} = \frac{20^{th} + 21^{th}}{2} = \frac{27 + 27}{2} = 27$ and

c The mode $m_o = 27$

2 You calculate the deviations from the mean, the median and the mode:

x	f	Deviation about the mean		Deviation about the median		Deviation about the mode	
		$ x - \bar{x} $	$f x - \bar{x} $	$ x - m_d $	$f x - m_d $	$ x - m_o $	$f x - m_o $
9	3	15.6	46.8	18	54	18	54
15	5	9.6	48	12	60	12	60
21	10	3.6	36	6	60	6	60
27	12	2.4	28.8	0	0	0	0
33	7	8.4	58.8	6	42	6	42
39	3	14.4	43.2	12	36	12	36
	40		261.6		252		252

3 Find the sum of the deviations and divide by the sum of the frequencies to get the mean deviations which will be;

i $MD(\bar{x}) = \frac{\sum f|x - \bar{x}|}{\sum f} = \frac{261.6}{40} = 6.54$

ii $MD(m_d) = \frac{\sum f|x - m_d|}{\sum f} = \frac{252}{40} = 6.3$

iii $MD(m_o) = \frac{\sum f|x - m_o|}{\sum f} = \frac{252}{40} = 6.3$

3 Mean deviation for grouped frequency distributions

For continuous grouped frequency distributions, mean deviation is calculated in the same way as above except that each x_i is substituted by the midpoint of each class (m_i) and

$$\therefore MD(\bar{x}) = \frac{\sum_{i=1}^n f_i |m_i - \bar{x}|}{\sum_{i=1}^n f_i}, \quad MD(m_d) = \frac{\sum_{i=1}^n f_i |m_i - m_d|}{\sum_{i=1}^n f_i}, \quad MD(m_0) = \frac{\sum_{i=1}^n f_i |m_i - m_0|}{\sum_{i=1}^n f_i}$$

Example 6 Find the mean deviation about the mean, the median and the mode for the following.

x	0 – 5	6 – 11	12 – 17	18 – 23	24 – 29
f	5	8	7	10	3

Solution

1 First, you have to find the mean, mode and median of the distribution.

x	f	m	fm	cf
0 – 5	5	2.5	12.5	5
6 – 11	8	8.5	68	13
12 – 17	7	14.5	101.5	20
18 – 23	10	20.5	205	30
24 – 29	3	26.5	79.5	33
$\sum f = 33$		$\sum fm = 466.5$		

a Mean = $\frac{\sum fm}{\sum f} = \frac{466.5}{33} = 14.14$

b Median = $L + \left(\frac{\left(\frac{n}{2} - cf_b \right)}{f_c} \right) w = 11.5 + \left(\frac{(16.5 - 13)}{7} \right) 6 = 11.5 + 3 = 14.5$

c Mode = $L + \left(\frac{\Delta_1}{\Delta_1 + \Delta_2} \right) w = 17.5 + \left(\frac{3}{3 + 7} \right) 6 = 17.5 + 1.8 = 19.3$

2 Determine the deviations and calculate the means of these deviations.

x	f	m	$ m - \bar{x} $	$f m - \bar{x} $	$ m - m_d $	$f m - m_d $	$ m - m_0 $	$f m - m_0 $
0 – 5	5	2.5	11.64	58.20	12	60	16.8	84
6 – 11	8	8.5	5.64	45.12	6	48	10.8	86.4
12 – 17	7	14.5	0.36	2.52	0	0	4.8	33.6
18 – 23	10	20.5	6.36	63.6	6	60	1.2	12
24 – 29	3	26.5	12.36	37.08	12	36	7.2	21.6
$\sum f = 33$		$\sum f m - \bar{x} = 206.52$		$\sum f m - m_d = 204$		$\sum f m - m_0 = 237.6$		

The mean deviation will then be:

- a** mean deviation about the mean

$$MD(\bar{x}) = \frac{\sum f |m - \bar{x}|}{\sum f} = \frac{206.52}{33} = 6.26$$

- b** mean deviation about median

$$MD(m_d) = \frac{\sum f |m - m_d|}{\sum f} = \frac{204}{33} = 6.18$$

- c** mean deviation about the mode

$$MD(m_0) = \frac{\sum f |m - m_0|}{\sum f} = \frac{237.6}{33} = 7.2$$

Mean deviation can be useful for applications. If our average is “Arithmetic mean” you take the deviation about the mean, if our average is “Median” then you take the deviation about the median, and if our average is the “Mode”, you take mean deviation about the mode.

To decide which one of the mean deviations to use in a given situation, consider the following points: If the degree of variability in a set of data is not very high, use of the mean deviation about the mean is comparatively the best for interpretation. Whenever there is an extreme value that can affect the mean, mean deviation about the median is preferable.

Mean deviation, though it has some advantages, is not commonly used for interpretation. Rather, it is the standard deviation that is commonly used and which tends to be the best measure of variation.

Advantages of mean deviation

Compared to range and quartile deviations, mean deviation has the following advantages: Range and inter-quartile ranges (discussed below) consider only two values; Mean deviation takes each value into consideration.

Limitation

By taking absolute value of deviation, it ignores signs of deviation, which violates the rules of algebra.

Exercise 8.5

- 1** Calculate the mean deviation about the mean, median and mode of each of the following data sets:

a 19, 15, 12, 20, 15, 6, 10

b 5, 6, 7, 9, 10, 10, 11, 12, 13, 17

2 Calculate the mean deviation about the mean, median and mode for these data sets:

a

x	1	2	3	4	5
f	3	1	4	2	1

b

x	12	13	14	15	16	17
f	4	11	3	8	5	4

c

x	0 - 4	5 - 9	10 - 14	15 - 19	20 - 24
f	3	5	7	4	3

d

x	10 - 14	15 - 19	20 - 24	25 - 29
f	5	25	10	4

Range and inter-quartile range (IQR)

ACTIVITY 8.9



The following are the average daily temperatures (in °C) one week for two cities, A and B.

City A: 15, 16, 16, 10, 17, 20, 14

City B: 13, 16, 15, 15, 14, 16, 17

- 1** Find the first and the third quartiles for each city.
- 2** Determine $Q_3 - Q_1$ for each city.
- 3** Compare which city has a higher variation in temperature.

In the previous sub-unit, we mentioned range as the difference between the highest and the lowest values in a data set. Sometimes, it may not be possible to get the range, especially in open ended data, where highest or lowest value may be unknown. It may sometimes also be true that the range is highly affected by extreme values. Under such circumstances, it may be of interest to measure the difference between the third quartile and the first quartile, which is called the Inter-quartile range. Inter-quartile range is a measure of variation which overcomes the limitations of range. It is defined as follows:

$$\text{IQR} = Q_3 - Q_1 \quad (\text{difference between upper and lower quartiles})$$

Example 7 Consider the following two sets of data:

A: 2, 7, 7, 7, 7, 7, 7, 10

B: 2, 3, 5, 8, 9, 10

The range of A and B are $R_A = 10 - 2 = 8$ and $R_B = 10 - 2 = 8$

from which you see that they have the same range. However, if you observe the two sets of data, you can see that data B is more variable than data A.

Example 8 Calculate the IQR of A and B.

Solution

For data A:

$$Q_1 = \left(\frac{8+1}{4} \right)^{\text{th}} \text{ item} = (2.25)^{\text{th}} \text{ item, which is 7, and}$$

$$Q_3 = \left(\frac{3(8+1)}{4} \right)^{\text{th}} \text{ item} = 6.75^{\text{th}} \text{ item, which is 7.}$$

$$\therefore \text{Inter-quartile range (IQR}_A) = 7 - 7 = 0$$

For Data B:

$$Q_1 = \left(\frac{6+1}{4} \right)^{\text{th}} \text{ item} = (1.75)^{\text{th}} \text{ item which is 2.75, and}$$

$$Q_3 = \left[\frac{3(6+1)}{4} \right]^{\text{th}} \text{ item} = (5.25)^{\text{th}} \text{ item which is 9.25.}$$

$$\therefore \text{Inter - Quartile range (IQR}_B) = Q_3 - Q_1 = 9.25 - 2.75 = 6.5$$

from which you see clearly that data B possesses higher variability than data A. The greater the measure of variation, the greater the variability (dispersion) of the data set.

\therefore Since $\text{IQR}_B > \text{IQR}_A$ data B is more variable.

Limitation of Inter-Quartile Range

- 1 It only depends on two values Q_3 and Q_1 . It doesn't consider the variability of each item in the data set.
- 2 It ignores 50% of the data (the top 25% above Q_3 and the bottom 25% below Q_1). It only considers the middle 50% of values between Q_1 and Q_3 .

Standard deviation

You have already seen how to calculate the standard deviation of ungrouped and grouped frequency distributions. You have also seen other measures of dispersion.

ACTIVITY 8.10

A certain shop has registered the following data on daily sales (in 100 Birr) for ten consecutive days.

30 45 54 60 25 35 42 80 70 40

- 1 Calculate the different measures of dispersion (range, inter-quartile range, mean deviation and standard deviation).
- 2 Discuss similarities and differences between the different measures of dispersion.



From the previous discussion, you know that mean deviation and standard deviation consider all the data values. However, mean deviation assumes only the absolute deviations of each data value from the central value (mean, median or mode). Hence it misses algebraic considerations. To overcome the limitation of mean deviation, you have a better measure of variation which is known as standard deviation. You may recall that standard deviation is given by:

$$s = \sqrt{\frac{\sum(x_i - \bar{x})^2}{n-1}} \quad \text{for sample ungrouped data and}$$

$$\sigma = \sqrt{\frac{\sum(x_i - \mu)^2}{N}} \quad \text{for population data}$$

When considering standard deviation we notice that, unlike the mean deviations, you always take the deviations from the arithmetic mean in standard deviation.

Since the deviation is squared, the sign becomes non-negative without violating the rules of algebra. Thus, standard deviation is the one that is mostly used for statistical analysis and interpretation. It is also used in conjunction with the mean for comparing degrees of variability and consistency of two or more different data sets.

Example 9 Find the standard deviation of the following data.

- a** 6, 6, 6, 6, 6, 6, 6 $\bar{x} = 6$

x	$x - \bar{x}$	$(x - \bar{x})^2$
6	0	0
6	0	0
6	0	0
6	0	0
6	0	0
6	0	0
6	0	0
6	0	0
		$\sum(x - \bar{x})^2 = 0$

$$s = \sqrt{\frac{\sum(x_i - \bar{x})^2}{n-1}} = \sqrt{\frac{0}{n-1}} = 0$$

Since $s = 0$, it indicates that there is no variability in the data set.

Note: The greater the standard deviation, the higher the variability.

8.5 ANALYSIS OF FREQUENCY DISTRIBUTIONS

ACTIVITY 8.11



Consider these two groups of similar data:

Data A: 1, 2, 3, 4, 5, 6, 7, 8, 9 and

Data B: 5, 4, 5, 5, 5, 5, 6, 5, 5

Compare the two data sets. Which of these two data sets is more consistent? Why?

The two data sets given above both have an average of 5. How is it possible to compare these data sets? Can you conclude that they are the same? It is obvious that these two data sets are not the same in consistency.

Example 1 The daily income of three small shops is recorded for five days. Which shop has consistent income (in Birr)?

Shops	A	B	C
	28	35	29
	36	32	39
	42	41	23
	25	27	33
	29	25	36

$$\bar{x}_A = \bar{x}_B = \bar{x}_C = 32$$

For shop A			For shop B			For Shop C		
x	$x - \bar{x}$	$(x - \bar{x})^2$	x	$x - \bar{x}$	$(x - \bar{x})^2$	x	$x - \bar{x}$	$(x - \bar{x})^2$
28	-4	16	35	3	9	29	-3	9
36	4	16	32	0	0	39	7	49
42	10	100	41	9	81	23	-9	81
25	-7	49	27	-5	25	33	1	1
29	-3	9	25	-7	49	36	4	16
$\sum (x - \bar{x})^2 = 190$			$\sum (x - \bar{x})^2 = 164$			$\sum (x - \bar{x})^2 = 156$		

Based on the values in the above table, we see that

$$S_A = \sqrt{\frac{\sum (x_i - \bar{x})^2}{n-1}} = \sqrt{\frac{190}{5-1}} = \sqrt{\frac{190}{4}} = 6.89;$$

$$S_B = \sqrt{\frac{\sum (x_i - \bar{x})^2}{n-1}} = \sqrt{\frac{164}{5-1}} = \sqrt{\frac{164}{4}} = 6.40, \text{ and}$$

$$S_C = \sqrt{\frac{\sum(x_i - \bar{x})^2}{n-1}} = \sqrt{\frac{156}{5-1}} = \sqrt{\frac{156}{4}} = 6.24$$

The comparison shows that $S_C < S_B < S_A$. Since $S_C < S_B < S_A$, then shop C has the most consistent income. The income of shop A is highly variable.

In the discussion given above, you used standard deviations to compare consistency, where the data sets considered have the same mean and the same unit. But, you may face data sets that do not have the same mean. You may also face data sets that do not have the same unit. If the units are different, it will be difficult to compare them. For example, for two sets of data A and B, if $S_A = 1.6$ k.g and $S_B = 1.7$ cm which of the data sets A or B is more variable?

You cannot compare kg to cm. Hence, you need to see a relative measure of variation which is a pure number. Such a pure number, which is used as a relative measure of variation, is the coefficient of variation given by:

$$CV = \frac{s}{\bar{x}} \times 100.$$

Example 2 Consider the following data on the mean and standard deviation of the gross incomes of two schools A and B.

School	Mean income (in Birr)	Standard deviation (in Birr)
A	8000	120
B	8000	140

From this table, you see that both schools have the same mean of 8000 Birr. Does equality of the means indicate that these two schools have the same variability and consistency?

Obviously, the answer is no, because the two data sets do not have the same standard deviation. For such a case, when you need to compare the consistency of two or more data sets, you can use another measure called the coefficient of variation (CV).

The **Coefficient of variation** is a unit-less relative measure that we use to measure the degree of consistency given as a ratio of the standard deviation to the mean.

$$C.V = \frac{\text{standard deviation}}{\text{mean}} \times 100 = \frac{\sigma}{\bar{x}} \times 100$$

For the above example, $C.V_A = \frac{120}{8000} \times 100 = 1.5$ and $C.V_B = \frac{140}{8000} \times 100 = 1.75$.

When you compare these two data sets, you can see that $CV_B > CV_A$ from which you can conclude that data set A is more consistent than data set B because data set B has a higher degree of variability.

You can also see the ratio of the coefficients of variation, given as

$$\frac{C.V_A}{C.V_B} = \frac{1.5}{1.75} = \frac{120}{140} = \frac{\sigma_1}{\sigma_2}$$

from which you can conclude that the data set with lesser

standard deviation is more consistent than the data set with larger standard deviation.

Example 3 The following are the mean and the standard deviation of height and weight of a sample of students.

height	weight
$\bar{x} = 168\text{cm}$ $s = 2.3 \text{ cm}$	$\bar{x} = 54\text{kg}$ $s = 1.6 \text{ kg}$

Which of the measured values (height or weight) has the higher variability?

$$C.V(\text{height}) = \frac{s}{\bar{x}} \times 100 = \frac{2.3\text{cm}}{168\text{cm}} \times 100 = 1.369\%$$

$$C.V(\text{weight}) = \frac{s}{\bar{x}} \times 100 = \frac{1.6\text{kg}}{54\text{kg}} \times 100 = 2.963\%$$

Since $C.V(\text{weight}) > C.V(\text{height})$, the students have greater variability in weight.

Exercise 8.6

1 Two basketball teams scored the following points in ten different games as follows:

Team A: 42 17 83 59 72 76 64 45 40 32

Team B: 28 70 31 0 59 108 82 14 3 95

- Calculate the standard deviation of each team.
- Which team scored more consistent points?

2 The mean and standard deviation of gross incomes of two companies are given below:

Company	Mean	Standard deviation
A	6000	120
B	10000	220

- Calculate the C.V of each company.
- Which company has the more variable income?

8.6 USE OF CUMULATIVE FREQUENCY CURVES

In section 8.3 of this unit, you saw three types of frequency curves whose shapes can be symmetrical, skewed to the left or skewed to the right. The shape of a frequency curve describes the distribution of a data set. Such a description was made possible after you drew the frequency curve of a frequency distribution.

In this sub-unit, you will see how the measures of central tendency (mean, mode and median) determine the skewness of a distribution.

8.6.1 Skewness Based on the Relationships Between Mean, Median and Mode

ACTIVITY 8.12



Consider the following data

Data A : 2, 3, 4, 5, 5, 6, 5, 7, 8 Data B: 2, 3, 1, 4, 8, 5, 8, 6, 8

- 1 Calculate and compare the mean, median and mode for each data set.
- 2 Construct frequency curves for each data set and discuss your observations.

Relative measures of variation help to study the consistency or variation of the items in a distribution. How do measures of central tendency help in studying the skewness of a distribution? What happens to the skewness if mean = median = mode?

A measure of central tendency or a measure of variation alone does not tell us whether the distribution is symmetrical or not. It is the relationship between the mean, median and mode that tells us whether the distribution is symmetrical or skewed.

Example 1 Consider the following frequency distribution of age of students in a class:

- a Draw the histogram and frequency curve.
- b Calculate mean, median and mode.
- c Describe relationships between the mean, median and mode, and the skewness of the distribution.

Age	Number of students
13 – 14	5
15 – 16	15
17 – 18	30
19 – 20	15
21 – 22	5
	70

Solution

- a** The histogram and frequency curve of this frequency distribution are as follows.

Histogram and frequency curve of age of students

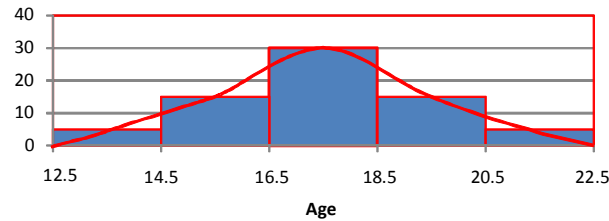

Figure 8.21

This appears to be symmetrical.

- b** Mean = median = mode = 17.5
c From **a** and **b**, you see that whenever mean = median = mode, the distribution is symmetrical.

Investigate what happens to the skewness of a distribution, if $\text{mean} > \text{median} > \text{mode}$?

From the discussions outlined above, you can make the following generalizations.

- i** For a unimodal distribution in which the values of mean, median and mode coincide (i.e., Mean = Median = Mode), the distribution is said to be **symmetrical**.

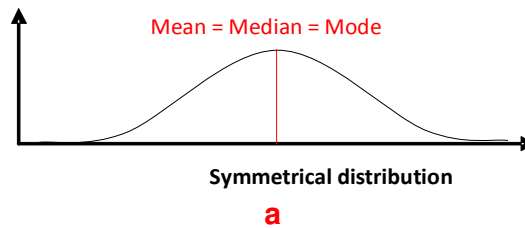

- ii** If the mean is the largest in value, and the median is larger than the mode but smaller than the mean, then the distribution is positively skewed. That is, if $\text{Mean} > \text{Median} > \text{Mode}$, then the distribution is **positively skewed** (skewed to the right).

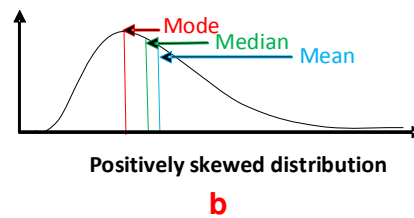

- iii** If the mean is smallest in value, and the median is larger than the mean but smaller than the mode, then the distribution is negatively skewed. That is, if $\text{Mean} < \text{Median} < \text{Mode}$ then the distribution is **negatively skewed** (skewed to the left).

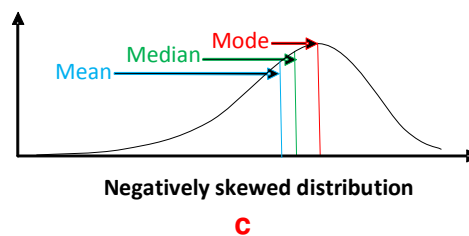

Figure 8.22

8.6.2 Skewness Based on Relationships Between Measures of Central Tendency and Measures of Variation

In the above discussion, we used the relationships between the measures of central tendency only to determine the skewness of a distribution. With the help of central tendencies and standard deviation, it is also possible to determine skewness of a distribution. This is sometimes called a mathematical measure of skewness. Mathematically, skewness can be measured in one of the following ways by calculating a coefficient of skewness.

- 1 Karl Pearson's coefficient of skewness
- 2 Bowley's coefficient of skewness

1 Karl Pearson's coefficient of skewness

Karl Pearson's coefficient of skewness (usually called Pearson's coefficient of skewness) is obtained by expressing the difference between the mean and the median relative to the standard deviation. It is usually denoted by α .

$$\text{Coefficient of skewness} = \alpha = \frac{3(\text{mean} - \text{median})}{\text{standard deviation}}$$

The interpretation of skewness by this approach follows our prior knowledge. From the previous discussion, if mean = median, we can see that the distribution is symmetrical. Looking at Pearson's coefficient of skewness, if $\alpha = 0$ then mean = median, so the distribution is symmetrical. Following the same approach, we can state the following interpretation on skewness using Pearson's coefficient of skewness.

Interpretation

- 1 If Pearson's coefficient of skewness $\alpha = 0$, the distribution is symmetrical.
- 2 If Pearson's coefficient of skewness $\alpha > 0$ (positive), the distribution is skewed positively (skewed to the right).
- 3 If Pearson's coefficient of skewness $\alpha < 0$ (negative), the distribution is negatively skewed (skewed to the left).

Example 2 Calculate Karl Pearson's coefficient of skewness from the data given below and determine the skewness of the distribution.

x	11	12	13	14	15
f	3	9	6	4	3

Solution Mean = 12.8, median = 13, and $s = 1.2$

$$\text{Coefficient of skewness} = \frac{3(\text{mean} - \text{median})}{s} = \frac{3(12.8 - 13)}{1.2} = -0.5$$

$$\text{Coefficient of skewness} = -0.5 < 0$$

\therefore The distribution is negatively skewed.

2 Bowley's coefficient of skewness

Previously, you saw how to determine skewness by using relationships between mean, median and standard deviation. It is also possible to determine skewness by using positional measures of central tendency, the quartiles. Such a coefficient of skewness, that uses quartiles, is called Bowley's coefficient of skewness.

Bowley's coefficient of skewness, which is usually denoted by β , is given by

$$\text{Bowley's coefficient of skewness} = \beta = \frac{Q_3 + Q_1 - 2(\text{median})}{Q_3 - Q_1}$$

The interpretation for skewness based on Bowley's coefficient of skewness is also the same as that of Pearson's that

- 1 If Bowley's coefficient of skewness $\beta = 0$, the distribution is symmetrical.
- 2 If Bowley's coefficient of skewness $\beta > 0$ (positive), the distribution is skewed positively (skewed to the right).
- 3 If Bowley's coefficient of skewness $\beta < 0$ (negative), the distribution is negatively skewed (skewed to the left).

Example 3 Find Bowley's coefficient of skewness for the following data and determine the skewness of the distribution.

15, 18, 19, 3, 2, 7, 10, 6, 9, 8

Solution Arranging the data in ascending order, you get:

2, 3, 6, 7, 8, 9, 10, 15, 18, 19.

From this arranged data, you can determine the quartiles as

$$Q_1 = 4.5 \quad Q_2 = \text{median} = 8.5 \quad Q_3 = 12.5$$

$$\begin{aligned} \text{Bowley's coefficient of skewness} = \beta &= \frac{Q_3 + Q_1 - 2(\text{median})}{Q_3 - Q_1} \\ &= \frac{12.5 + 4.5 - 2(8.5)}{12.5 - 4.5} = \frac{17 - 17}{8} = 0 \end{aligned}$$

\therefore the distribution is symmetrical.



Key Terms

bar chart	mean deviation
coefficient of variation	non random sampling technique
frequency curve	population
frequency polygon	sample random sampling technique
histogram	skewness
inter - quartile range	standard deviation
line graph	symmetrical distribution



Summary

- 1** **Statistics** refers to methods that are used for collecting, organizing, analyzing and presenting numerical data.
- 2** Statistics is helpful in business research, proper understanding of economic problems and the formulation of economic policy.
- 3** A **population** is the complete set of items which are of interest in any particular situation.
- 4** It is not possible to collect information from the whole population because it is costly in terms of time, energy and resources. To overcome these problems, we take only a certain part of the population called a **sample**.
- 5** A sample serves as representative of the population, so that we can draw conclusions about the entire population based on the results obtained from the sample.
- 6** There are two methods of sampling
 - ✓ The **Random (probability)** sampling method.
 - ✓ The **Non-Random (non-probability)** sampling method.
- 7** In **random sampling**, every member of the population has an equal chance of being selected.
- 8** **Raw data**, which has been collected, can be presented in frequency distributions and pictorial methods.
- 9** The purpose of presenting data in frequency distributions is to
 - ✓ condense and summarize large amount of data.

- 10** The purpose of presenting data using pictorial methods is to
- ✓ facilitate comparisons between two or more sets of data;
 - ✓ convey messages about the nature of data at a glance.
- 11** Measures of variation help to decide the degree of variability.
- 12** There are two types of measures of variation
- i absolute and
 - ii relative.
- 13** Range = $x_{max} - x_{min}$
- 14** Inter quartile range = $Q_3 - Q_1$
- 15** Mean deviation about the mean = $MD(\bar{x}) = \frac{\sum |x - \bar{x}|}{n}$
- 16** Mean deviation about the median = $MD(m_d) = \frac{\sum |x - m_d|}{n}$
- 17** Mean deviation about the mode = $MD(m_o) = \frac{\sum |x - m_o|}{n}$
- 18** For a given distribution:
- ✓ if $\bar{x} > m_d > m_o$ the distribution is positively skewed
 - ✓ if $\bar{x} < m_d < m_o$ the distribution is negatively skewed
 - ✓ if $\bar{x} = m_d = m_o$ the distribution is symmetrical
- 19** Pearson's coefficient of skewness = $\frac{3(\text{mean} - \text{median})}{\text{standard deviation}}$
- ✓ $\alpha = 0$ means the distribution is symmetrical.
 - ✓ $\alpha > 0$ means the distribution is positively skewed.
 - ✓ $\alpha < 0$ means the distribution is negatively skewed.
- 20** Bowley's coefficient of skewness = $\beta = \frac{Q_3 + Q_1 - 2(\text{median})}{Q_3 - Q_1}$
- ✓ $\beta = 0$ means the distribution is symmetrical.
 - ✓ $\beta > 0$ means the distribution is positively skewed.
 - ✓ $\beta < 0$ means the distribution is negatively skewed.



Review Exercises on Unit 8

- 1 Define population and sample.
- 2 Write down advantages of simple random sampling, systematic sampling and stratified sampling techniques.
- 3 Explain the difference between a frequency polygon and a frequency curve.
- 4 What benefits do statistical graphs have in helping understand and interpret data?
- 5 What does skewness mean about a distribution?
- 6 Explain similarities and differences between simple, component and multiple bar charts.
- 7 Discuss mean deviation from the mean, median and mode, and explain the advantages of each.
- 8 What limitations do range and inter-quartile range have?
- 9 Why is it useful to use standard deviation over other measures of dispersion?
- 10 The ages of 50 people are given below

21	75	15	60	72	40	46	65	70	45
22	34	35	53	64	66	63	80	34	36
21	45	72	38	23	45	40	69	24	39
40	30	50	60	24	38	35	45	27	66
45	34	54	24	38	66	46	32	45	40

- a What type of data is this? (discrete or continuous)
 - b Select suitable classes and prepare a frequency distribution.
 - c Draw a histogram to present the data.
 - d Draw a frequency polygon.
- 11 Consider the following table

Year	Average production in tonnes		
	Wheat	Maize	Total
1960	440	250	690
1961	170	362	532
1962	620	657	1277

Present the above data using

- a a simple bar chart
- b a component bar chart
- c a multiple bar chart
- d a pie chart

- 12 a** Find the mean, median and mode, 1st quartile and 3rd quartile of the following data:

Class	0 - 9	10 - 19	20 - 29	30 - 39
frequency	2	10	13	8

- b** Using the above data calculate
- i** the mean deviation about the mean, mode and median;
 - ii** the range and inter-quartile range;
 - iii** the standard deviation;
 - iv** the coefficient of variation;
 - v** Pearson's coefficient of skewness and describe the skewness of the distribution.
- 13** The following data reports the performance of workers in two companies.

Company	A	B
Average hours worked in a week	30	28
Standard deviation in performance	5	8

Workers of which company are more consistent in their performance?

- 14** The following data represents hours in a day 30 individuals worked in soil and water conservation.

4	6	5	3	8	9	4	6	7	3
2	3	5	5	6	6	3	8	1	6
4	5	7	8	2	4	3	6	4	3

Using the above data calculate

- i** the mean deviation about the mean, mode and median.
- ii** the range and inter-quartile range.
 - iii** the standard deviation.
 - iv** the coefficient of variation.



MATHEMATICAL APPLICATIONS FOR BUSINESS AND CONSUMERS

Unit Outcomes:

After completing this unit, you should be able to:

- *find unit cost, the most economical purchase price and the total cost.*
- *apply percent decrease to business discounts.*
- *calculate the initial expense of buying a house and the ongoing expenses of owning it.*
- *calculate commissions, total hourly wages and salaries.*

Main Contents

9.1 Applications to purchasing

9.2 Percent increase and percent decrease

9.3 Real estate expenses

9.4 Wages

Key terms

Summary

Review Exercises

INTRODUCTION

The main goal of this unit is to help you start thinking about how to apply classroom calculations to your everyday life. For example, before making purchases, you need to know how much you can spend, how much you can buy, and which are the most economical purchases available to you. On a bigger scale, you need to determine the kind of lifestyle you want or expect, before you can identify the type of job you would need in order to support it. Along the same lines, when multiple job opportunities present themselves to you, you need to be able to calculate relative incomes based on the salaries, wages and commissions that you could earn.

In short, you need to know your net income and your net worth for many reasons. One of the most important times for knowing this is when you want to buy a house, especially if you are contemplating taking out on a mortgage for it.



OPENING PROBLEM

Ato Gemechu wants to purchase a house for Birr 795,000 from Sunshine Real Estate. Because he can't afford this price all at once, he has chosen an alternative: paying 20% of the purchase-price now and then paying the remainder over 30 years at 9% annual interest, compounded monthly. According to this schedule, can you calculate his expected monthly payments?

9.1

APPLICATIONS TO PURCHASING

One of the most difficult tasks in calculating the financial consequences of alternatives is estimating exactly how costs differ. In this section, you will learn how to use *unit cost* to determine the most economical purchase.

ACTIVITY 9.1



- 1 Shiferaw buys 6 notebooks at Birr 6.25 each.
 - a How much must he pay?
 - b How much change will he get, if he pays with a Birr 50 note?
- 2 Five pens cost Birr 4.75.
 - a Find the cost of each pen.
 - b How much do 11 pens cost?

Note that *unit cost* is the cost of one unit, and *total cost* is obtained by multiplying the unit cost by the number of units. Now look at the following examples.

Example 1 If 20 litres of kerosene cost Birr 170, what is the cost of kerosene per litre?

Solution
$$\text{unit cost} = \frac{\text{total cost}}{\text{number of units}} = \frac{\text{Birr } 170}{20\text{litre}} = \text{Birr } 8.50 \text{ per litre}$$

Example 2 How much would you pay for 120 textbooks at Birr 25.30 each, 50 pens at Birr 1.50 each and 30 dozen erasers at Birr 0.75 each?

Solution Total cost = unit cost \times number of units.

Total price for textbooks: $120 \times \text{Birr } 25.30 = \text{Birr } 3,036$

Total price for pens: $50 \times \text{Birr } 1.50 = \text{Birr } 75$

Total price for erasers: $30 \times 12 \times \text{Birr } 0.75 = \text{Birr } 270$

Thus, the total cost is Birr 3036 + Birr 75 + Birr 270 = Birr 3,381.

Example 3 One store sells 6 cans of cola for Birr 20.40, and another store sells 24 cans of the same brand for Birr 79.20. Find the better buy.

Solution To determine the most economical purchase, you need to know the unit cost.

$$\text{Birr } 20.40 \div 6 = \text{Birr } 3.40$$

$$\text{Birr } 79.20 \div 24 = \text{Birr } 3.30$$

Hence, buying 24 cans for Birr 79.20 better value.

Exercise 9.1

- 1** Find the total cost of 15 rolls of wallpaper at Birr 26.80 per roll, 3 litres of paint at Birr 18.40 per litre and 5 brushes at Birr 6.30 each.
- 2** Find the more economical purchase: 5kg of nails for Birr 32.50 or 4 kg of nails for Birr 25.80.
- 3** A family buys 3 children's meals that cost Birr 32.15 each and 2 value meals that cost Birr 52.00 each. How much does the family spend altogether?
- 4** Iman wants to buy 12 bottles of lemonade for her birthday party. At Bambis Supermarket, lemonade is on a "buy one, get one at half price" special offer. The bottles cost Birr 7.25 each.
 - a** How much does Iman pay for the 12 bottles of lemonade?
 - b** How much does she save because of the special offer?
- 5** Megeressa is paid Birr 35.40 per hour. He can work for up to 30 hours per week.
 - a** What is the maximum amount of money he can earn in a week?
 - b** How many hours per week should he work if he wants to earn Birr 991.20?

9.2 PERCENT INCREASE AND PERCENT DECREASE

9.2.1 Review of Percentage

The word "cent" comes from the Latin word "centum", meaning one hundred. The word "percent" means "for every hundred". Percent is denoted by the symbol %. You use the term "percent" frequently. For example, test grades are usually expressed in percentages: "I got 85% on my mathematics test". Interest on loans is also expressed using percentages: "I just bought a new house - the cost of the house is Birr 250,000, and the interest rate is 8.5%." "The rate of inflation is slowing. For the last quarter, the average cost of living rose only 1% per month."

ACTIVITY 9.2



- 1 Find 28% of 850.
- 2 What percentage of 1500 is 75?
- 3 Mohammed got 17 out of 20 in his Geography test, 84% in his Mathematics test and 45 out of 50 in his English test. In which subject did he score best?
- 4 Beza sold 24 oranges. If this was 12% of her oranges, how many oranges are unsold?

Working out percentages

Recall that $\text{Rate (R)} \times \text{Base (B)} = \text{Percentage (P)}$.

Example 1 Find 15% of 420.

Solution Here, 15% = 0.15 is called the rate (expressed in percent);

420 is the base (entire amount), and $P = R \times B$.

So $P = 0.15 \times 420 = 63$

Example 2 What is the number whose 30% is 600?

Solution

Given: $R = 30\% = 0.30$. $P = 600$. **Required:** B

$$\text{As } P = R \times B, \quad B = \frac{P}{R} = \frac{600}{0.30} = 2000$$

Example 3 $\frac{7}{10}$ of the surface of the earth is water. Express this as a percentage.

Solution $\frac{7}{10} \times 100\% = 70\%$

9.2.2 Percentage Increases and Decreases

Example 4 MOENCO increases the price of a Toyota car by 20%. If the original price was Birr 170,000, calculate its new price.

Solution

Method 1

$$20\% \text{ of Birr } 170,000 = 0.20 \times \text{Birr } 170,000 = \text{Birr } 34,000.$$

Now add this to the original price:

$$\text{New price} = \text{Birr } 170,000 + \text{Birr } 34,000 = \text{Birr } 204,000.$$

Method 2

The original price represents 100%, and therefore the increased price can be represented as 120%:

$$120\% \text{ of Birr } 170,000 = 1.20 \times \text{Birr } 170,000 = \text{Birr } 204,000$$

Example 5 A shop is offering a 15% discount on its goods for Christmas. If the price of a shirt in the shop was Birr 150 before the discount, what is the current (sale) price of the shirt?

Solution

Method 1

Step 1 Find the discount, 15% of Birr 150:

$$0.15 \times \text{Birr } 150 = \text{Br } 22.50$$

Step 2 Deduct the discount:

$$\text{Birr } 150 - \text{Birr } 22.50 = \text{Birr } 127.50$$

Method 2

Since the original price represents 100%, the shirt is now being sold at 85%.

$$\text{Therefore, } 85\% \text{ of Birr } 150 = 0.85 \text{ Birr} \times 150 = \text{Birr } 127.50$$

9.2.3 Percentage Profit and Loss

When people sell goods for a living, they try to make some money from their sales. The amount of money made on the sale of an article is called the **profit**. If the goods are sold for less than the trader paid for them, he/she makes a loss.

The price a trader pays for an article is called the **cost price (c. p.)**.

The price at which articles are sold to the public is known as the **selling price (s.p.)**.

If the selling price is greater than the cost price, the trader makes a **profit**. If the cost price is greater than the selling price, the trader suffers a **loss**. Both profit and loss are calculated as percentages of the cost price, as shown below:

$$\text{Percentage profit} = \frac{\text{actual profit}}{\text{original (cost) price}} \times 100\%$$

$$\text{Percentage loss} = \frac{\text{actual loss}}{\text{original (cost) price}} \times 100\%$$

Example 6 A mobile phone is bought for Birr 1200 and sold for Birr 1600. What is the percentage profit?

Solution Actual profit = selling price – cost price: Birr 1600 – Birr 1200 = Birr 400

$$\therefore \text{Percentage profit} = \frac{\text{profit}}{\text{cost}} \times 100\% = \frac{\text{Birr } 400}{\text{Birr } 1200} \times 100\% = 33\frac{1}{3}\%$$

Example 7 A person buys a car for Birr 150,000 and sells it for Birr 130,000. Calculate the percentage loss.

Solution Loss = c.p. – s.p = Birr 150,000 – Birr 130,000 = Birr 20,000

$$\text{Percentage loss} = \frac{\text{loss}}{\text{cost}} \times 100\% = \frac{\text{Birr } 20,000}{\text{Birr } 150,000} \times 100\% = 13\frac{1}{3}\%$$

Exercise 9.2

- 1 If 25% of a number is 70, what is the number?
- 2 A salesman earned Birr 600 in commissions. If his commission was 10% of his sales, what was the amount of his sales?
- 3 A football team played 30 matches last season. If they won 70% of the games and drew 20% of the games, how many games did they lose?
- 4 8 students out of 20 failed an examination. What percentage of students passed?
- 5 In an examination, 10% of the candidates were absent. 62% of those who appeared passed. If 513 candidates failed, how many were enrolled for the examination?
- 6 A car dealer buys a car for Birr 1,200 and then sells it for Birr 1,500. What is the percentage profit?
- 7 A damaged sofa which cost Birr 4,200 when new, is sold for Birr 3,000. What is the percentage loss?
- 8 A woman buys 200 apples for Birr 400. She sells them for Birr 1.75 each. Calculate the percentage profit or loss made.
- 9 In order to increase sales, the price of a pair of shoes is reduced from Birr 450 to birr 360. What percentage reduction is this?
- 10 The price of sugar increased from Birr 5.50 to Birr 13.75 per kg. What is the percentage increase?

- 11 A rectangle has dimensions 15cm by 25cm. Calculate the percentage increase in the area of the rectangle after both the length and the width are increased by 20%.
- 12 The price of teff has increased by 10%. By what percentage must consumption be reduced so as to keep the expenditure constant?
- 13 I am 10% older than my wife. My wife is $x\%$ younger than me. Find x .
- 14 Find the compound interest on Birr 200 invested for 3 years at 4% interest per annum.
- 15 A man with a monthly salary of Birr 3,000 has allowances of Birr 250. If the income tax rate is 35%, what is his net income?
- 16 A television is priced at Birr 2,800.00, including VAT. If the added VAT is 15%, find:
 - a the price of the TV before VAT was added;
 - b the amount of VAT paid.
- 17 At a sale, prices are reduced by 20%. Find the original price of an article that has a sale price of Birr 90.
- 18 An article costing Birr 250 is sold at a profit of 25%. Find the selling price.
- 19 A broker sold a second-hand car for Birr 80,000, thereby making a profit of 18% on his cost price. Find his cost price.
- 20 The population of Addis Ababa increases by 5% each year. At this rate, after how many years will the current population be doubled?
- 21 A woman with an income of Birr 2400 and allowances of Birr 150 paid Birr 337.50 in tax. What is the rate of taxation?

9.2.4 Merchandising: Markup, Based on Cost and Selling Price

Definition 9.1

Merchandising Business: A business whose main activity is that of buying and selling a product.

Cost Price (c.p.) is either the price at which a dealer buys the goods or the cost incurred by a company in producing it.

Selling Price (s.p.) is the price at which a dealer sells the goods.

Mark-up (Mu) is the difference between the selling price and the cost price. i.e.,

$$\text{Mu} = \text{s.p.} - \text{c.p.}$$

Do you see the difference between mark-up and profit?

The following example should make it clear:

Assume that W/rt Sara owns a cosmetic shop where she sells cosmetics. Before she can sell the cosmetics, she must buy them from a wholesaler. W/rt Sara must add a certain amount of money (called the mark-up) to the cost of each cosmetic to arrive at the desired selling price. The mark-up must cover both the expenses related to the sale (like transport, rent, wages, utilities) and the amount of profit desired on each cosmetic.

Hence,

$$\text{mark-up} \geq \text{profit.}$$

Also note that mark-up is usually expressed in terms of a percent:

$$\text{percent} = \frac{\text{percentage}}{\text{base}} \times 100,$$

where percent = mark-up percent
 percentage = mark-up
 base = selling price or cost price

Definition 9.2

Discount (D) is a reduction in the original selling price.

Regular (Marked) price is the price at which an article is offered for sale.

Sale Price is the price that the customer pays in the case of a discounted article, the sales price is obtained by deducting the discount from the marked price.

Note:

The terms **discount** and **markdown** can be used interchangeably.

The percent of markdown is always based on the original selling price.

Hence, you have the following relationship:

$$\text{Discount (d)} = \text{Marked price (m.p.)} - \text{selling price (s.p.)}$$

$$\text{Discount rate} = \frac{\text{Amount of discount}}{\text{marked price}} \times 100\%$$

Discussion: *Why do merchants offer discounts?*

Example 8 Find the mark-up, if cost price and selling price are Birr 20.40 and Birr 28.90, respectively.

Solution Mark-up = selling price – cost price = Birr 28.90 – Birr 20.40 = Birr 8.50

Example 9 What is the mark-up on an automobile that sells for Birr 145,000 and costs the dealer Birr 129,000?

Solution Mark-up = selling price – cost price
 = Birr 145,000 – Birr 129,000 = Birr 16,000

Example 10 A used-car dealer acquired a 2003 Opel for Birr 80,000 and sold it for Birr 100,000. What was the rate of mark-up, based on the cost?

Solution

Required: mark-up rate

$$\text{markup rate (\%)} = \frac{\text{mark up}}{\text{cost price}} \times 100\% = \frac{\text{Birr } 20,000}{\text{Birr } 80,000} \times 100\% = 25\%$$

Example 11 A shirt selling for Birr 180 cost the seller Birr 150. What is the percent markup based on selling price?

Solution markup = s.p. - c.p. = Birr 180 - Birr 150 = Birr 30

$$\text{markup \%} = \frac{\text{markup}}{\text{selling price}} \times 100\% := \frac{\text{Birr } 30}{\text{Birr } 180} \times 100\% = 16\frac{2}{3}\%$$

Example 12 A pair of shoes has a mark-up of Birr 80, which is 15% of the selling price. What is the selling price?

Solution markup \% = $\frac{\text{markup}}{\text{selling price}} \times 100\%$

$$15\% = \frac{\text{Birr } 80}{\text{selling price}} \times 100\%$$

$$\text{Selling price} = \frac{\text{Birr } 80}{0.15} = \text{Birr } 533.33$$

Example 13 Calculate the discount and selling price (net price) for a Birr 600 radio offered at 18% discount.

Solution Amount of discount = discount rate \times regular price (marked or list price):

$$= 18\% \times \text{Birr } 600 = 0.18 \times \text{Birr } 600 = \text{Birr } 108$$

The discount is Birr 108, and hence the selling price for the radio is

$$\text{Birr } 600 - \text{Birr } 108 = \text{Birr } 492$$

Example 14 Calculate the regular price of a television set, assuming that a 20% discount would have been worth Birr 400.

Solution

$$\text{Discount rate} = \frac{\text{discount}}{\text{regular price}} \times 100\%$$

$$20\% = \frac{\text{Birr } 400}{\text{regular price}} \times 100\%$$

$$\text{Regular price} = \frac{\text{Birr } 400}{0.20} = \text{Birr } 2,000$$

Exercise 9.3

Complete the following table.

1 Calculate the sales discount and the sale price of the items pictured.

	Purchase	Price	% Discount	Discount	Sale price
a		Birr 220	10%	Birr ____	Birr ____
b		Birr 450	20%	Birr ____	Birr ____
c		Birr 4,200	____	Birr ____	Birr <u>3,600</u>
d		Birr 600	____	Birr 150	Birr ____
e		____	25%	Birr ____	Birr 8,000

2 Fill in the missing information, assuming the rate of markup is based on the cost price.

	Selling price	Cost price	Mark-up	Rate of markup
a	Birr 240	Birr 220	____	____
b	____	Birr 160	Birr 40	____
c	Birr 1000	____	Birr 300	____
d	____	Birr 300	____	10%
e	Birr 720	____	____	25%
f	____	____	Birr 100	15%

- 3** A furniture company determines that a mark-up of 30% on its furniture must be made in order to cover reasonable expenses, while still remaining competitive. If the furniture cost the company Birr 950, what should it sell for?
- 4** A sofa was priced to sell at Birr 8,000. It was finally marked down by 15%. What is the net (selling) price?
- 5** A book that costs Birr 20, and that was priced to sell at Birr 35, was marked down by 12%. What is the amount of the discount?
- 6** Haimanot spent Birr 12,000 on a laptop, on sale for 10% off the marked price. What was the initial marked price of the laptop?
- 7** Which is the best deal?
- a** a 15% discount followed by a 45% discount?
 - b** a 20% discount followed by a 40% discount?
 - c** a 10% discount followed by a 50% discount?

9.3 REAL ESTATE EXPENSES

9.3.1 Initial Expenses of Buying a House

A house is usually the most expensive item that someone will purchase in his/her lifetime. Since a house is expensive, the way that many people are able to afford a home is by taking out a long-term loan, also known as a mortgage.

Mortgage

A mortgage is an amount that is borrowed, often from a bank, to buy real estate. A person will not be able to get a loan for the full purchase price of the house, because the lender expects him/her to pay a percentage of the purchase price immediately.

The money that is paid at the time of purchase is called the **down payment** (usually 20%) and the remaining money still to be paid is known as the **mortgage** or **balance due**. Thus,

$$\text{mortgage} = \text{purchase price} - \text{down payment}$$

Instalment plan

An instalment plan is a system in which an item is bought by paying a certain amount of money now, as the cash price of the item, and then paying the remainder later, in periodic payments (typically monthly).

Instalment charge

The instalment charge is the interest paid on the unpaid balance.

Monthly payment

The monthly payment is the amount of money to be paid every month.

Example 1 W/o Teresa bought a house from Sunshine Real estate by paying 20% of the purchase (cash) price, which is Birr 450,000.

- a** Find the down payment.
- b** Find the mortgage amount.

Solution

a Down payment = 20% of 450,000 = $\frac{20}{100} \times \text{Birr } 450,000 = \text{Birr } 90,000$

b Mortgage = purchase price - down payment
 = Birr 450,000 - Birr 90,000 = Birr 360,000

You have seen that one of the major initial expenses in buying a house is the down payment. In addition, there are other costs (like loan-origination fee, appraisal fee, home-inspection fee, title insurance, etc.) that you must pay to your lender.

These expenses are called **closing costs**. Of all these closing costs, the biggest expense, and an expense that must be paid at the beginning, is the **loan-origination fee**. Most states have laws governing the maximum amount of interest that can be charged to a buyer of a *private home*.

Since the rate of interest that lending agencies can charge is restricted by law, they have found a way to "get around the law" by charging the borrower "points". *Points* is a term used by banks to mean percent. For example, "8 points" means "8%".

This loan-origination fee is usually a percent of the mortgage:

$$\text{points} \times \text{mortgage} = \text{loan} - \text{origination fee.}$$

For example, a lender may agree to loan Birr 300,000 at 10%, but the loan is contingent on the borrower's paying, say, 6 points. That means, specifically, that the borrower must pay 6% of Birr 300,000 (Birr 18,000) just to obtain the loan. In addition, the borrower must pay back not only the Birr 300,000 purchase price but also interest at 10% accumulated over the time period specified.

Example 2 A home is purchased with a mortgage of Birr 600,000. The buyer pays a loan origination fee of $2\frac{1}{2}$ points. How much is the loan origination fee?

Solution loan origination fee = mortgage \times points
 = Birr 600,000 $\times 2\frac{1}{2}\%$ = Birr 15,000

ACTIVITY 9.3



Tigist would like to purchase an apartment that is selling for Birr 795,615 from Access real-estate. A mortgage on this dwelling would require a 20% down payment plus closing costs.

Fill in the missing items in the following table (round to the nearest Birr).

House price	Birr 795,615
Down payment	_____
Total amount to be financed	_____
the cash price of the item, and then paying the remainder later, in periodic payments (typically monthly).	
origination fee (3pts)	_____
Appraisal fee	Birr 1,200
Home inspection fee	Birr 2,400
Title insurance	Birr 6,700
Other fees	Birr 3,400
Total closing costs	_____
Total amount of mortgage loan (= Amount to be financed + Total closing costs)	_____

An important part of your decision of whether or not to purchase a house through a mortgage is the total cost over the life of the mortgage loan. You need to calculate the *total interest* that you would pay and add that to the *principal*, which is the actual purchase price of the house itself.

You might be surprised at the large amount of interest you would pay over the life of the loan. For example, consider buying the house that is described at the end of the last section (in which we were discussing loan-origination fees).

9.3.2 Ongoing Expenses of Owning a House

As you can recall from the previous discussion, you have seen that the major initial expenses in the process of buying a home are the **down payment** and the **loan-origination fee**. In this section, you will look at the continuing monthly expenses involved in owning a house. The monthly mortgage payment, utilities, insurance, home-inspection fee, and taxes are some of these ongoing expenses. Of these expenses, the largest one is normally the monthly mortgage payment.

Definition 9.3

Amortization is a process in which a debt is “retired” in a given length of time of equal payments. The payments include compound interest. At retirement, the borrower has paid the entire amount of the principal and the interest.

A loan is amortized, if both the principal and interest are paid off with a single periodic payment whose amount is fixed for the life of the loan. The percentages of the payment that go toward paying the principal and the interest, respectively, are not necessarily fixed within the fixed payment.

The most common example of an amortized loan is a home mortgage, which is typically paid off in monthly instalments over a period of 10 to 30 years.

The amount of the monthly mortgage payment depends on three factors: the amount of the loan, the interest rate on the loan and the number of years required to pay back the loan.

Note that the monthly mortgage payment includes the payment of both the *principal* and the *interest* on the mortgage. The interest charged during any one month is charged against the unpaid balance of the loan.

Note:

The amortization formula is given by:

$$p \cdot p = p \cdot \frac{i}{1 - (1 + i)^{-n}}$$

where $p \cdot p \equiv$ periodic payment
 $p \equiv$ principal
 $i \equiv$ interest rate per payment interval
 $n \equiv$ number of payments made

Example 3 Calculate the monthly payment on Birr 200,000 at a 6% annual interest rate that is amortized over 10 years.

Solution Principal (p) = Birr 200,000

$$\text{Interest rate, per payment interval (i)} = \frac{6\%}{12} = \frac{0.06}{12} = 0.005$$

$$\text{Number of payments made (n)} = 10 \times 12 = 120$$

$$\begin{aligned} p \cdot p &= p \frac{i}{1 - (1 + i)^{-n}}, \text{ where } p = \text{Birr } 200,000, \text{ and } i = .005. \\ &= \text{Birr } 200,000 \times \frac{0.005}{1 - (1.005)^{-120}} = \text{Birr } 2,220.41 \end{aligned}$$

Thus, the monthly payment is Birr 2,220.41.

Note that calculating the monthly payment using the above method is fairly difficult. So, tables given at the end of this book are used to simplify the calculations.

Exercise 9.4

- 1 Suppose you borrow Birr 95,000 from a bank to buy a car and agree to repay the loan in 48 equal monthly payments, including all interest due. If the bank charges 2% per month on the unpaid balance, compounded monthly, how much is each payment required to retire the total debt including the interest?
- 2 A mortgage of Birr 300,000, at interest of 3% per annum, is to be repaid in five years by making equal payments of principal and interest at the end of each year. Calculate the amount of each payment.

Example 4 To calculate the monthly payment on the loan in **Example 3** above, using the monthly payment table, we obtain 0.01110205, corresponding to 10 years and 6.0%.

Then, $\text{Birr } 200,000 \times 0.01110205 = \text{Birr } 2,220.41$, (as already calculated above).

Exercise 9.5

- 1 Using the monthly payment table, calculate these monthly mortgage payments.
 - a On a 30-year Birr 80,000 mortgage, at an interest rate of 7%;
 - b On a Birr 150,000 loan, at a rate of 8.5%, to be paid back monthly over a period of 5 years.
- 2 Complete the table, rounding your answers to the nearest cent.

	Amount of loan	Interest rate	Number of years	Monthly payment
a	Birr 20,000	6%	15	_____
b	Birr 160,000	$7\frac{1}{2}\%$	25	_____
c	Birr 450,000	12%	10	_____
d	Birr 1,000,000	9%	30	_____

- 3 Find the monthly payment on an auto loan of Birr 450,000 to be amortized over a 15 year period at a rate of 10%.
- 4 Ato Toga purchased a condominium for Birr 140,000 and made a down payment of 15%. The-savings-and-loan association from which he purchased his mortgage charges an annual interest rate of 9.5% on Toga's 20-year mortgage. Find the monthly mortgage payment.
- 5 W/o Yeshe financed a Birr 2,500 TV. If she will be making 36 monthly payments of Birr 82.44, what rate of financing did she receive?

9.4 WAGES

Why do people do work?

The American psychologist Abraham Maslow developed a model of human needs to show how people are motivated to work. This model is called a hierarchy of needs, because it starts with basic needs at the bottom (food, clothes and shelter) and climbs to higher needs at the top. In short, most of us work for one or more of the following five reasons. Typically, according to Maslow, the reasons have this order of importance:

- ✓ We want to earn money.
- ✓ We want security - to know that we will have money in the future.
- ✓ We want to have friends and a sense of being part of a team.
- ✓ We want to feel good about what we do, what we have achieved and who we are.
- ✓ We want to be encouraged and allowed to do better.

Note:

There are two major types of employment: **full time** and **part time**.

Both full time and part-time jobs are available. A job can last many years or only 2 - 3 weeks, depending on the type of employment:

- ✓ permanent – the job can last as long as the company is in business.
- ✓ temporary – the job lasts for a limited time.

As explained above, the main reason why everybody works is to get money. There are three ways to receive payment for doing work: commissions, wages and salaries.

Commission

At times, it becomes impractical for a business owner to assume all the functions of buying and selling. To relieve their work loads, business owners hire salespeople. The means of paying such salespeople varies. Some receive a salary, others receive a commission on the sales they make, and still others are paid through a combination of both salary and commission.

A commission is a fee given to such an employee that represents a certain percentage of the total sales made by the employee. As you are probably aware, many salespeople are rewarded by commission. The commission is often expressed as a percentage of sales, and it may either be the sole means of wage payment or a supplement to a salary. For example, a real estate salesperson may earn a commission of $2\frac{1}{2}\%$ on all sales (called a straight commission based on a single percentage). In contrast, a salesperson working for a manufacturer may earn a monthly salary of Birr 600 and a commission of 5% on all sales (called a **salary-plus commission**).

Example 1 A real estate broker, Kedir, receives a commission of $1\frac{1}{2}\%$ of the selling price of a house. Find the commission he earned for selling a home for Birr 350,000.

Solution $1\frac{1}{2}\%$ of Birr 350,000 = $0.015 \times 350,000 =$ Birr 5,250

Example 2 A salesperson earns a monthly salary of Birr 750 and a 6% commission on sales over Birr 30,000. If the total monthly sales are Birr 80,000, calculate his/her total income.

Solution

Step 1 Calculate the amount of sales over Birr 30,000.

$$\text{Birr } 80,000 - \text{Birr } 30,000 = \text{Birr } 50,000$$

Step 2 Multiply this result (i.e Birr 50,000) by 6% to determine the amount of the commission:

$$\text{Birr } 50,000 \times 6\% = \text{Birr } 3,000$$

Step 3 Calculate his/her total income:

$$\text{Birr } 750 + \text{Birr } 3,000 = \text{Birr } 3,750$$

Exercise 9.6

- 1** Gossaye, a car dealer, receives a 6% commission from car sales. What is his commission on Birr 140,000 of sales?
- 2** ETHOF pays a 15% commission on sales up to Birr 2,000 and 5% on the amount of sales above Birr 2,000. How much does a salesperson earn on a sale of Birr 4,600?
- 3** A salesperson is paid 10% of the first Birr 150,000 in sales, 15% of the next Birr 50,000 in sales, and 20% of all sales over Birr 200,000. What are the employee's annual earnings if sales are Birr 340,000?
- 4** A salesperson sells Birr 80,000 worth of goods in a week. What is the week's salary if the basic salary is Birr 400 a week plus a 5% commission on all sales up to Birr 50,000 and a 10% commission on all sales over Birr 50,000?
- 5** A real estate company pays its salespeople the following commissions on all sales:
 - 3% on the first Birr 600,000
 - 5% on the next Birr 400,000
 - 7.5% on any sales over Birr 1,000,000

Commissions are paid monthly. Determine the commissions earned by the following employees:

Employee	Monthly Sales
Abdulaziz	Birr 521,780.00
Yohannes	Birr 814,110.90
Sherif	Birr 1.5 million
Elias	Birr 986,352.20

Wages and salaries

Definition 9.4

Wages A wage is a payment for services rendered. Usually unskilled (manual) workers are paid weekly wages. These are calculated according to the number of hours worked.

Example 3 Regular time for an employee is 40 hrs per week. If more hours are worked, the worker is paid overtime. Overtime refers to the hours worked in excess of regular time or normal working hours, which are usually 8 hours in a day or 40 hours in a week. Overtime pay is usually $1\frac{1}{2}$ times the regular hourly rate. This overtime rate is called **time-and-a-half**.

For instance, if your hourly rate is Birr 40, then your overtime rate is

$$1.5 \times \text{Birr } 40 = \text{Birr } 60 \text{ per hour.}$$

Work performed on Sundays or public holidays is usually paid at 2 times the regular hourly rate. This rate is called **double time**.

Also workers may get fringe benefits (which are not included in their pay packet), like use of a company car, a company pension, private health care, use of a subsidised cafeteria and discounts on products/goods and services.

Salaries

If, instead of being paid on an hourly basis, an employee is paid by the week, the month, or the year, he or she is said to be "on a salary". Most skilled workers (professionals) are paid a salary. A salary is a fixed amount of money that may be paid monthly, weekly, or biweekly, regardless of the number of hours worked. For instance, if someone is contracted for 40 hours per week and he/she works 60 hours, then he/she will not be paid for the extra 20 hours he/she has worked. In short, the job of a salaried person is designed to take about 8 hours a day, 5 days a week, and if more time is required, the salaried employee is expected to put in that time without extra compensation.

Examples 4 W/o Serkalem, an administrative assistant at Addis Ababa University, earns Birr 28,800 a year and works 40 hours each week. Find her monthly salary and hourly rate of pay.

Solution Birr $28,800 \div 12 = \text{Birr } 2,400$

She gets Birr 2,400 per month, and to get her hourly rate of pay, you proceed as follows:

$$\text{Birr } 28,800 \div 52 = \text{Birr } 553.85 \text{ (Why is it divided by 52?)}$$

Birr 553.85 is her weekly salary, and hence,

$$\text{Birr } 553.85 \div 40 = \text{Birr } 13.85 \text{ is the amount she is paid per hour.}$$

The above figures are rounded sensibly.

Example 5 A plumber receives an hourly wage of Birr 15.50. Find the plumber's total wages for working 36 hours.

Solution Hours worked \times hourly rate = *gross pay*

$$36 \times \text{Birr } 15.50 = \text{Birr } 558$$

Example 6 Teklay worked 50 hours last week at an hourly rate of Birr 25.00 plus time -and-a-half for working over 40 hours per week. What is his gross pay?

Solution Regular hours \times hourly rate = *regular pay* = $40 \times \text{Birr } 25 = \text{birr } 1,000$

$$\text{Overtime hours} \times \text{overtime rate} = \text{overtime pay} = 10 \times (1.5 \times 25) = \text{Birr } 375$$

(Overtime rate usually = $1\frac{1}{2}$ times the regular rate)

$$\text{Gross pay} = \text{regular pay} + \text{overtime pay} = \text{Birr } 1,000 + \text{Birr } 375 = \text{Birr } 1,375.$$

Exercise 9.7

- 1** Find the gross pay of an employee who worked $30\frac{1}{4}$ hours at an hourly rate of Birr 20.75. (Round the answer sensibly)
- 2** Seneshaw received Birr 604.50 gross pay for the $32\frac{1}{2}$ hours he worked. What is his hourly rate?
- 3** Complete the following table:

Name	Mon	Tues	Wed	Thurs	Fri	Hourly rate	Gross pay
Naomi	6	$7\frac{1}{2}$	8	8	$4\frac{1}{2}$	Birr 30.00	_____
Genet	7	8	7	_____	6	Birr 40.00	Birr 1,320
Ayantu	5	8	8	4	4 hours 45 min	_____	Birr 743.75

- 4 Ato Lemma worked the following hours:

Mon	Tues.	Wed	Thurs	Fri	Sat	Sun
$6\frac{1}{2}$	9	10	8	7	0	4

Find his gross pay if he is paid Birr 20.00 per hour, plus time-and-a-half for hours in excess of 40, and double-time for any hours worked on Sunday.

- 5 Determine the annual salary of an employee who is paid Birr 450 biweekly.



Key Terms

amortization	marked price	percentage profit
commissions	mark-up	periodic payment
cost price	merchandising business	principal
discount	monthly payment	purchasing
discount rate	mortgage	salaries
down payment	percentage	sale price
initial expenses	percentage decrease	selling price
instalment charge	percentage increase	wages
instalment plan	percentage loss	



Summary

- The word “cent” comes from the Latin word “centum” meaning **one hundred**. The word “percent” means **for every hundred** and is denoted by the symbol %.
- The amount of money made on the sale of an article is called the **profit**.
- A **merchandising business** is a business whose main activity is that of buying and selling a product.
- The **Cost price** is the price at which a dealer buys an item of goods or is the amount spent by a company to produce it.
- The **Selling price** is a price at which a dealer sells the goods.
- The **Markup** is the difference between the selling price and the cost price.
- A **Discount** is a reduction in the original selling price.
- The **Regular price** (**marked price**) is the price at which an article is offered for sale.

- 9** A **mortgage** is a loan for a specific amount of money that is borrowed to buy real estate. The loan is issued by a bank or by another lending agency that operates on behalf of a bank.
- 10** An **Instalment plan** is a system in which an item can be bought by paying an initial amount of money as a partial cash price for the item, and in which the unpaid balance is paid later, in regular payments (usually monthly).
- 11** An **Instalment charge** is the interest paid on the unpaid balance of an instalment-plan purchase.
- 12** **Amortization** is a process in which a debt is retired in a given length of time of equal payments that includes the compound interest. The debt has been completely paid off at the end of that period.
- 13** The amortization formula is given by:
- $$p.p = p \cdot \frac{i}{1 - (1+i)^{-n}}$$
- Where; $p.p$ = periodic payment; p = principal
 i = interest rate per payment interval
 n = number of payments made
- 14** There are two major types of work: **Full time** and **part time**.
- 15** A **Wage** is a payment for services rendered.



Review Exercises on Unit 9

- 1** Pencils cost 80 cents each.
- How much would 15 pencils cost?
 - How many pencils can you buy for Birr 19.20?
- 2** Ali works as an assistant teacher, and his income is Birr 1, 800 a month. Last year he spent 20% of his incomes on house rent. What was the total amount he spent per week on renting the house?
- 3** Bethel works 40 hours per week, for which she is paid Birr 1000.
- How much is she paid per hour?
Her earnings increased to Birr 1,200 per week.
 - How much is she now paid per hour?
 - Calculate the percentage increase in her earnings.

- 4** Senay buys 6 packs of biscuits a week, and each pack costs Birr 5.50. He works 20 hours a week at a wage of Birr 22.00 per hour. What percent of his weekly income does Senay spend on biscuits?
- 5** One day, Zekarias works from 8:30 until 11:00. He is paid Birr 15.50 per hour. How much does he earn for his day's work?
- 6** Alemitu's salary is Birr 2400, which is 25% more than the salary of her husband, Wassihun. How much is Wassihun's salary?
- 7** Because of the construction of the new road (including the Renaissance Bridge over the Nile river) from Addis to Gondar, the driving time between the two cities is reduced from 14 hours to 9 hours. What percentage decrease does this represent?
- 8** The Vestel TV company labels a TV with a regular price of Birr 4,000. A wholesaler gets a 40% discount, an electrician gets a 30% discount and a consumer gets a 15% discount. How much will each pay for the TV?
- 9** Moges wants to buy a house that costs Birr 250,000. He has saved Birr 50,000 which he will use as a deposit, and will finance the rest of the cost by taking out a loan. The loan is to be paid back in equal monthly instalments, amortized over 30 years, at an annual interest rate of 7%. What will his monthly payment be?
- 10** A beauty salon has 4 employees pays them each Birr 8 per hour. Each employee receives time-and-a-half for hours worked over 40. Complete the following table; calculate the number of hours each employee worked, for regular wages and for overtime wages during the week. Also calculate the number of hours on which each employee's gross wage is based.

Employee	Mon	Tue	Wed	Thu	Fr.	Sat	Total hrs	Regular hrs	Overtime hrs	Regular pay	Overtime pay	Gross pay
Abdissa	7	9	8	11	10	3						
Tekeste	8	8	6	10	4	-						
Guji	$8\frac{1}{4}$	-	$7\frac{3}{4}$	9	$5\frac{1}{2}$	$6\frac{1}{2}$						
Gizachew	9	8	8	11	10	4						

- 11** Abraham dialled 200 telephone calls in a month. Each call costs 40 cents. The monthly telephone rental charge is Birr 8.00. If VAT was charged at 15%, find the total amount of Abraham's telephone bill.
- 12** Which is the better buy?
- a** A 600 g block of chocolate for Birr 25.00, or a 500 g block, plus 20% extra free, for Birr 28.00.
- b** 200 g pasta, plus 20% extra, for Birr 18.70, or 250 g pasta, plus 25% extra, for Birr 30.00.

TABLE OF MONTHLY PAYMENT

Annual Interest Rate																
Yrs	6.0%	6.5%	7.0%	7.5%	8.0%	8.5%	9.0%	9.5%	10.0%	10.5%	11.0%	11.5%	12.0%	12.5%	13.0%	13.5%
1	0.0860664	0.0862964	0.0865268	0.0867574	0.0869884	0.0872198	0.0874515	0.0876835	0.0879159	0.0881486	0.0883817	0.0886151	0.0888488	0.0890829	0.0893173	0.0895520
2	0.0443206	0.0445463	0.0447726	0.0449959	0.0452273	0.0454557	0.0456847	0.0459145	0.0461449	0.0463760	0.0466078	0.0468403	0.0470735	0.0473073	0.0475418	0.0477770
3	0.0304219	0.0306490	0.0308771	0.0311062	0.0313364	0.0315675	0.0317997	0.0320330	0.0322672	0.0325024	0.0327387	0.0329760	0.0332143	0.0334536	0.0336940	0.0339353
4	0.0234850	0.0237150	0.0239462	0.0241789	0.0244129	0.0246483	0.0248850	0.0251231	0.0253626	0.0256034	0.0258455	0.0260890	0.0263338	0.0265800	0.0268275	0.0270763
5	0.0193328	0.0195662	0.0198001	0.0200380	0.0202769	0.0205165	0.0207584	0.0210019	0.0212470	0.0214939	0.0217424	0.0219926	0.0222445	0.0224979	0.0227531	0.0230099
6	0.0165729	0.0168099	0.0170490	0.0172901	0.0175332	0.0177784	0.0180255	0.0182747	0.0185258	0.0187790	0.0190341	0.0192912	0.0195502	0.0198112	0.0200741	0.0203390
7	0.0146086	0.0148494	0.0150927	0.0153383	0.0155862	0.0158365	0.0160891	0.0163440	0.0166012	0.0168607	0.0171224	0.0173865	0.0176527	0.0179212	0.0181920	0.0184649
8	0.0131414	0.0133862	0.0136337	0.0138839	0.0141367	0.0143921	0.0146502	0.0149109	0.0151742	0.0154400	0.0157084	0.0159794	0.0162528	0.0165288	0.0168073	0.0170882
9	0.0120058	0.0122545	0.0125063	0.0127610	0.0130187	0.0132794	0.0135429	0.0138094	0.0140787	0.0143509	0.0146259	0.0149037	0.0151842	0.0154676	0.0157536	0.0160423
10	0.0111021	0.0113548	0.0116109	0.0118702	0.0121328	0.0123986	0.0126676	0.0129398	0.0132151	0.0134935	0.0137750	0.0140595	0.0143471	0.0146376	0.0149311	0.0152274
11	0.0103670	0.0106238	0.0108841	0.0111480	0.0114155	0.0116864	0.0119608	0.0122387	0.0125199	0.0128045	0.0130924	0.0133835	0.0136779	0.0139754	0.0142761	0.0145799
12	0.0097585	0.0100192	0.0102838	0.0105523	0.0108245	0.0111006	0.0113803	0.0116637	0.0119508	0.0122414	0.0125356	0.0128332	0.0131342	0.0134386	0.0137463	0.0140572
13	0.0092472	0.0095119	0.0097807	0.0100537	0.0103307	0.0106118	0.0108968	0.0111857	0.0114785	0.0117750	0.0120753	0.0123792	0.0126867	0.0129977	0.0133121	0.0136299
14	0.0088124	0.0090810	0.0093540	0.0096314	0.0099132	0.0101992	0.0104894	0.0107837	0.0110820	0.0113843	0.0116905	0.0120006	0.0123143	0.0126317	0.0129526	0.0132771
15	0.0084386	0.0087111	0.0089883	0.0092701	0.0095565	0.0098474	0.0101427	0.0104423	0.0107461	0.0110540	0.0113660	0.0116819	0.0120017	0.0123252	0.0126524	0.0129832
16	0.0081144	0.0083908	0.0086721	0.0089583	0.0092493	0.0095449	0.0098452	0.0101499	0.0104590	0.0107724	0.0110900	0.0114117	0.0117373	0.0120667	0.0123999	0.0127367
17	0.0078310	0.0081112	0.0083966	0.0086871	0.0089826	0.0092829	0.0095880	0.0098978	0.0102121	0.0105308	0.0108538	0.0111810	0.0115122	0.0118473	0.0121862	0.0125287
18	0.0075816	0.0078656	0.0081550	0.0084497	0.0087496	0.0090546	0.0093645	0.0096791	0.0099984	0.0103223	0.0106505	0.0109830	0.0113195	0.0116600	0.0120043	0.0123523
19	0.0073608	0.0076486	0.0079419	0.0082408	0.0085450	0.0088545	0.0091690	0.0094884	0.0098126	0.0101414	0.0104746	0.0108122	0.0111539	0.0114995	0.0118490	0.0122021
20	0.0071643	0.0074557	0.0077530	0.0080559	0.0083644	0.0086782	0.0089973	0.0093213	0.0096502	0.0099838	0.0103219	0.0106643	0.0110109	0.0113614	0.0117158	0.0120738
21	0.0069886	0.0072836	0.0075847	0.0078917	0.0082043	0.0085224	0.0088458	0.0091743	0.0095078	0.0098460	0.0101887	0.0105358	0.0108870	0.0112422	0.0116011	0.0119637
22	0.0068307	0.0071294	0.0074342	0.0077451	0.0080618	0.0083841	0.0087117	0.0090446	0.0093825	0.0097251	0.0100722	0.0104237	0.0107794	0.0111390	0.0115023	0.0118691
23	0.0066885	0.0069907	0.0072992	0.0076139	0.0079345	0.0082609	0.0085927	0.0089297	0.0092718	0.0096187	0.0099701	0.0103258	0.0106857	0.0110494	0.0114168	0.0117876
24	0.0065598	0.0068654	0.0071776	0.0074961	0.0078205	0.0081508	0.0084866	0.0088278	0.0091739	0.0095248	0.0098803	0.0102400	0.0106038	0.0109715	0.0113427	0.0117173
25	0.0064430	0.0067521	0.0070678	0.0073899	0.0077182	0.0080523	0.0083920	0.0087370	0.0090870	0.0094418	0.0098011	0.0101647	0.0105322	0.0109035	0.0112784	0.0116565
26	0.0063368	0.0066492	0.0069684	0.0072941	0.0076260	0.0079638	0.0083072	0.0086560	0.0090098	0.0093683	0.0097313	0.0100984	0.0104695	0.0108443	0.0112224	0.0116038
27	0.0062399	0.0065556	0.0068772	0.0072073	0.0075428	0.0078842	0.0082313	0.0085836	0.0089410	0.0093030	0.0096695	0.0100401	0.0104145	0.0107925	0.0111738	0.0115581
28	0.0061512	0.0064702	0.0067961	0.0071287	0.0074676	0.0078125	0.0081630	0.0085188	0.0088796	0.0092450	0.0096148	0.0099886	0.0103661	0.0107471	0.0111313	0.0115185
29	0.0060701	0.0063921	0.0067130	0.0070572	0.0073995	0.0077477	0.0081016	0.0084607	0.0088248	0.0091934	0.0095663	0.0099431	0.0103236	0.0107074	0.0110943	0.0114841
30	0.0059955	0.0063207	0.0066530	0.0069922	0.0073377	0.0076891	0.0080462	0.0084085	0.0087757	0.0091474	0.0095232	0.0099029	0.0102861	0.0106726	0.0110620	0.0114541

TABLE OF RANDOM NUMBERS

13962	70992	65172	28053	02190	83634	66012	70305	66761	88344
43905	46941	72300	11641	43548	30455	07686	31840	03261	89139
00504	48658	38051	59408	16508	82979	92002	63606	41078	86326
61274	57238	47267	35303	29066	02140	60867	39847	50968	96719
43753	21159	16239	50595	62509	61207	86816	29902	23395	72640
83503	51662	21636	68192	84294	38754	84755	34053	94582	29215
36807	71420	35804	44862	23577	79551	42003	58684	09271	68396
19110	55680	18792	41487	16614	83053	00812	16749	45347	88199
82615	86984	93290	87971	60022	35415	20852	02909	99476	45568
05621	26584	36493	63013	68181	57702	49510	75304	38724	15712
06936	37293	55875	71213	83025	46063	74665	12178	10741	58362
84981	60458	16194	92403	80951	80068	47076	23310	74899	87929
66354	88441	96191	04794	14714	64749	43097	83976	83281	72038
49602	94109	36460	62353	00721	66980	82554	90270	12312	56299
78430	72391	96973	70437	97803	78683	04670	70667	58912	21883
33331	51803	15934	75807	46561	80188	78984	29317	27971	16440
62843	84445	56652	91797	45284	25842	96246	73504	21631	81223
19528	15445	77764	33446	41204	70067	33354	70680	66664	75486
16737	01887	50934	43306	75190	86997	56561	79018	34273	25196
99389	06685	45945	62000	76228	60645	87750	46329	46544	95665
36160	38196	77705	28891	12106	56281	86222	66116	39626	06080
05505	45420	44016	79662	92069	27628	50002	32540	19848	27319
85962	19758	92795	00458	71289	05884	37963	23322	73243	98185
28763	04900	54460	22083	89279	43492	00066	40857	86568	49336
42222	40446	82240	79159	44168	38213	46839	26598	29983	67645
43626	40039	51492	36488	70280	24218	14596	04744	89336	35630
97761	43444	95895	24102	07006	71923	04800	32062	41425	66862
49275	44270	52512	03951	21651	53867	73531	70073	45542	22831
15797	75134	39856	73527	78417	36208	59510	76913	22499	68467
04497	24853	43879	07613	26400	17180	18880	66083	02196	10638
95468	87411	30647	88711	01765	57688	60665	57636	36070	37285
01420	74218	71047	14401	74537	14820	45248	78007	65911	38583
74633	40171	97092	79137	30698	97915	36305	42613	87251	75608
46662	99688	59576	04887	02310	35508	69481	30300	94047	57096
10853	10393	03013	90372	89639	65800	88532	71789	59964	50681
68583	01032	67938	29733	71176	35699	10551	15091	52947	20134
75818	78982	24258	93051	02081	83890	66944	99856	87950	13952
16395	16837	00538	57133	89398	78205	72122	99655	25294	20941
53892	15105	40963	69267	85534	00533	27130	90420	72584	84576
66009	26869	91829	65078	89616	49016	14200	97469	88307	92282
45292	93427	92326	70206	15847	14302	60043	30530	57149	08642
34033	45008	41621	79437	98745	84455	66769	94729	17975	50963
13364	09937	00535	88122	47278	90758	23542	35273	67912	97670
03343	62593	93332	09921	25306	57483	98115	33460	55304	43572
46145	24476	62507	19530	41257	97919	02290	40357	38408	50031
37703	51658	17420	30593	39637	64220	45486	03698	80220	12139
12622	98083	17689	59677	56603	93316	79858	52548	67367	72416
56043	00251	70085	28067	78135	53000	18138	40564	77086	49557
43401	35924	28308	55140	07515	53854	23023	70268	80435	24269
18053	53460	32125	81357	26935	67234	78460	47833	20496	35645

MATHEMATICS

STUDENT TEXTBOOK
Grade 12

ISBN 978-99944-2-048-3



FEDERAL DEMOCRATIC REPUBLIC OF ETHIOPIA
MINISTRY OF EDUCATION

Price ETB 60.90

MATHEMATICS

STUDENT TEXTBOOK
Grade 12

ISBN 978-99944-2-048-3



FEDERAL DEMOCRATIC REPUBLIC OF ETHIOPIA
MINISTRY OF EDUCATION

Price 60.90